

Endurant HD™ Automated Transmission TRSM0950 EN-US

May 2026

EEO-14F112C
EEO-15F112C
EEO-16F112C
EEO-17F112C
EEO-18F112C
EHD-14112C-N
EHD-14112C-V
EHD-16112C-V
EE-17F111B



BACKED BY
Roadranger
SUPPORT

General Information

| | |
|---|---|
| Warnings and Cautions | 1 |
| How to Use This Manual | 4 |
| Contact Information | 4 |
| Serial Tag Information and Model Nomenclature | 5 |

Service Procedures

| | |
|--|-----|
| Oil | 6 |
| Linear Clutch Actuator (LCA) | 9 |
| Transmission Control Module (TCM) | 16 |
| Transmission | 22 |
| Clutch | 31 |
| Fluid Pressure Sensor (FPS) | 52 |
| Output Speed Sensor | 55 |
| Mechatronic Transmission Module (MTM) | 60 |
| MTM Rail B, C and D Cylinder | 82 |
| MTM Rail B, C and D Cover Cap Screw | 99 |
| Release Bearing and Clutch Release Yoke | 115 |
| Upper Countershaft Cover | 125 |
| Input Shaft Cover | 136 |
| Lower Countershaft Cover and Inertia Brake | 146 |
| Output Yoke | 158 |
| Rear Bearing Cover | 160 |
| Harness Bracket | 169 |
| Rear Housing | 171 |
| 4-Bolt PTO Cover | 198 |
| 8-Bolt PTO Cover | 200 |
| Oil Pump Assembly | 205 |
| Main Housing | 233 |
| Main Shaft and Countershaft | 280 |

Disassembly / Assembly

| | |
|--|-----|
| Output Seal Assembly | 346 |
| Lower Countershaft Cover and Inertia Brake | 348 |
| Input Shaft Pilot Bearing Wear Sleeve | 352 |
| Input Shaft Cover | 358 |
| Main Shaft | 361 |
| Input Shaft | 371 |
| Main Housing | 384 |
| Rear Housing | 398 |
| Clutch Housing | 410 |

Appendix

| | |
|--|-----|
| OEM and Engine Specific Kits | 437 |
| Clutch Service Kits | 437 |
| Input Shaft Repair Kit | 442 |
| Pilot Bearings | 444 |
| Input Shaft Kit Part Number Identification | 445 |
| Input Shaft Kits | 447 |
| Transmission Service Unit, Reman or Complete, Part Number Identification | 451 |
| Oil Level Inspection Procedure | 454 |
| Oil Leak Inspection Process | 457 |
| Lubrication Specifications | 458 |
| Lubricant, PS-386 HD Synthetic Transmission .. | 458 |
| Maintenance and Lubricant Change Intervals .. | 458 |
| Vehicle Maintenance Recommendations | 459 |
| Roadranger Specialty Tools | 460 |
| Bearing Lock Templates | 462 |
| Inspection Precautions | 468 |
| Torque Specifications | 469 |
| Handling, Inspection and Cleaning of Parts | 470 |
| Recycling Parts and Oil | 471 |
| MTM Rail B, C and D Cylinder Inspection Procedure | 472 |
| Main Shaft End-Play Service Procedure | 480 |
| New Replacement Transmission Control Module (TCM) Service Procedure | 535 |
| Primary Drive Gear Replacement | 544 |
| RRMT0027 - Clutch Housing Front Cover Kit | 586 |
| Harness Bracket Service Procedure | 604 |
| Change Log | 606 |

Warnings and Cautions

The alert symbols, signal words (**DANGER**, **WARNING** and **CAUTION**) and statements throughout this manual indicate the potential severity of a situation. Ensure to read, understand and follow each statement to avoid vehicle damage, component damage, personal injury, severe injury and/or death.



DANGER: Indicates an immediate hazard. Failure to follow the indicated procedures will cause major vehicle component damage, severe injury or death.



WARNING: Indicates an immediate hazard. Failure to follow the indicated procedures may result in major vehicle component damage, severe injury or death.



CAUTION: Indicates a potential hazard. Failure to follow the indicated procedures could result in minor or moderate component damage and/or personal injury.

The NOTICE and Note statements throughout this manual provide additional details required to avoid damaging a component or incorrectly completing a repair. Ensure to read, understand and follow each statement to properly complete a repair.

NOTICE: Indicates component or property damage could result if you do not follow the indicated procedure.

Note: Indicates additional detail that will aid in the repair of a component.

While working on a vehicle:



WARNING: Do not modify transmission components or systems. Modification (altering, substituting, relocating) of transmission components may result in major vehicle component damage, severe injury or death.



WARNING: Do not modify transmission service tools. Modification (altering, substituting, relocating) of transmission service tools may result in major vehicle component damage, severe injury or death.



WARNING: Read, understand and follow each statement regarding cap screw installation and torque specification requirements. Failure to install and torque cap screws to specification may result in major vehicle component damage, severe injury or death.



WARNING: When working on vehicle components, keep body parts clear of sharp objects and pinch points. Failure to keep clear of sharp objects and pinch points may result in severe injury or death.



WARNING: Use appropriate lifting devices and equipment when working with heavy vehicle components. Failure to do so may result in major vehicle component damage, severe injury or death.



CAUTION: Do not work on the vehicle immediately after operation. Working on a hot vehicle component could result in personal injury.

Compressed Air System



WARNING: The vehicle air system operates approximately between 60 - 140 PSI. Refer to OEM guidelines regarding vehicle system operation and service. Failure to follow OEM guidelines may result in major vehicle component damage, severe injury or death.

Before starting a vehicle:

- Sit in the driver's seat.
- Confirm vehicle parking brake is applied.
- Confirm Neutral is selected on the driver interface device.
- Ensure vehicle has adequate fuel level.
- Do not operate the vehicle if the Alternator lamp is on or if gauge indicates low voltage with the engine running.

When parking the vehicle or leaving the cab:

1. Safely come to a complete stop.
2. Continue to depress and hold service brake.
3. Select Neutral on the driver interface device.
4. Apply vehicle parking brake.



WARNING: Apply vehicle parking brake and follow vehicle manufacturer parking instructions. Failure to follow these instructions could cause unintended vehicle movement and may result in major vehicle component damage, severe injury or death.

5. Turn ignition key Off and allow the engine to shut to down.

Before working on a vehicle or leaving the cab with engine running:

1. Safely come to a complete stop.
2. Continue to depress and hold service brake.
3. Select Neutral on the driver interface device.
4. Apply vehicle parking brake.



WARNING: Apply vehicle parking brake and follow vehicle manufacture parking instructions. Failure to follow these instructions could cause unintended vehicle movement and may result in major vehicle component damage, severe injury or death.

5. Chock wheels.

To avoid damage to the transmission during towing:

When towing a vehicle equipped with the Endurant HD Transmission, do not allow the output shaft of the transmission to rotate. If the vehicle is towed with the drive wheels still in contact with the road surface, the vehicle axle shafts or driveline must be removed or disconnected prior to towing vehicle.

NOTICE: Internal transmission damage can result from improper vehicle towing.

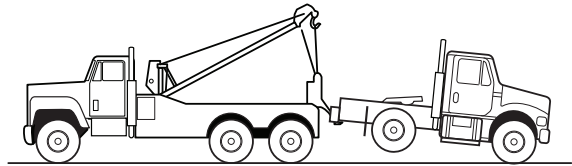
Preferred**Must remove vehicle axle shafts or driveline prior to towing**

After completing a transmission service procedure, ensure to complete the Configure Transmission Control Module (TCM) and/or Transmission Service Routines when directed.

Limited Driveline-Connected Towing

In an urgent situation, the vehicle may be towed after specific vehicle and transmission requirements are met at a limited road speed and distance with the driveline connected and the drive wheels in contact with the road surface.



CAUTION: Failure to follow the Limited Driveline-Connected Towing requirements listed below will result in transmission damage and voids the transmission warranty.

Vehicle and Transmission Requirements:

- Vehicle air pressure greater than 90 psi (620 kPa)
- Neutral (N) selected on the vehicle's transmission shift device
- Solid neutral (N) indicated in the vehicle's transmission shift device display
- Solid neutral (N) indicated in the vehicle's transmission gear display
- Key off

Limited Towing Speed and Distance Requirements:

- Road speed less than 25 mph (40 km/h)
- Distance less than 0.25 mile (0.40 km)

Configure Transmission Control Module (TCM)

Perform Configure Transmission Control Module (TCM) after completing the following component replacement procedures:

- Transmission assembly replacement
- MTM assembly replacement
- TCM assembly replacement

NOTICE: Failure to perform the Configure Transmission Control Module (TCM) results in incorrect vehicle and transmission component serial number information.

Transmission Service Routines

Perform Transmission Service Routines when advised by Eaton Cummins and after completing the following procedure:

- New Replacement Transmission Control Module - Grade Sensor Calibration

NOTICE: Failure to perform the Transmission Service Routines results in degraded transmission performance.

Clutch and Rail Calibrations

To ensure proper operation, the TCM, clutch, MTM and transmission require a Clutch and Rail Calibration.

Calibrations are required after:

- Linear Clutch Actuator (LCA) replacement or re-installation
- Transmission replacement or re-installation (anytime the transmission is re-installed, regardless of the service procedure performed)
- New Transmission Control Module (TCM) installation

Calibrations are automatically initiated when:

- "CC" in gear display
- LCA is in the reset position (or new TCM)
- Transmission in "N" (Neutral)
- Key on engine running
- Vehicle air system pressure at operating range

How to Use This Manual

This publication is divided into three sections: General Information, Service Procedures and Appendix.

General Information

This section contains basic chapters such as Transmission Overview, How to Use This Manual and Serial Tag and Model Nomenclature.

Service Procedures

To find the information you need, simply locate the procedure in the Table of Contents, turn to the page specified and follow the procedure.

The Service Procedures are divided in three sections; Removal, Disassembly/Assembly and Installation. Removal instructs how to remove the part or assembly from the transmission. Disassembly instructs how to take an assembly apart. Assembly instructs how to put together an assembly. Installation instructs how to install the part or assembly in the transmission. Not all parts have a disassembly/assembly section.

A Component Identification diagram is included at the beginning of each procedure for Removal, Disassembly/Assembly and Installation. Below the Component Identification diagram is a numerical listing for each part with the part name.

Appendix

This section contains additional details that support the service of the transmission such as service parts information, lubrication and torque specifications.

Contact Information

- U.S. and Canada Help Line: +1-800-826-4357
- Mexico Help Line: +52-800-800-6801

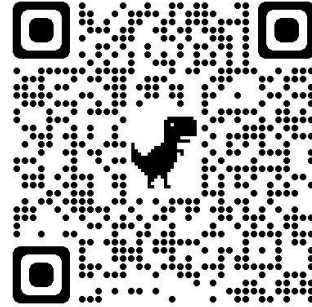

Serial Tag Information and Model Nomenclature

Transmission model designation and other transmission identification information are stamped on the serial tag. To identify the transmission model and serial number, locate the tag on the lower right side of the clutch housing.

When calling for service assistance or parts, have the model and serial numbers handy.

NOTICE: Do not remove or destroy the transmission identification tag.

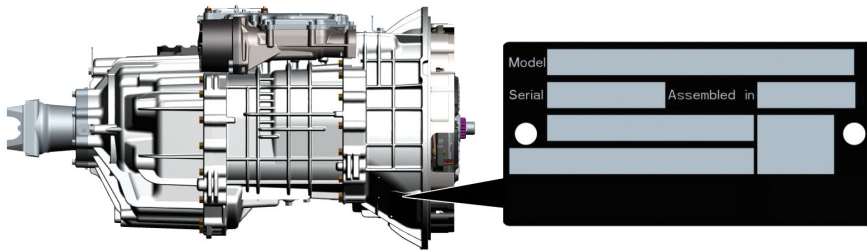

Model Number

The model number gives basic information about the transmission and is explained below. Use this number when calling for service assistance or replacement parts.

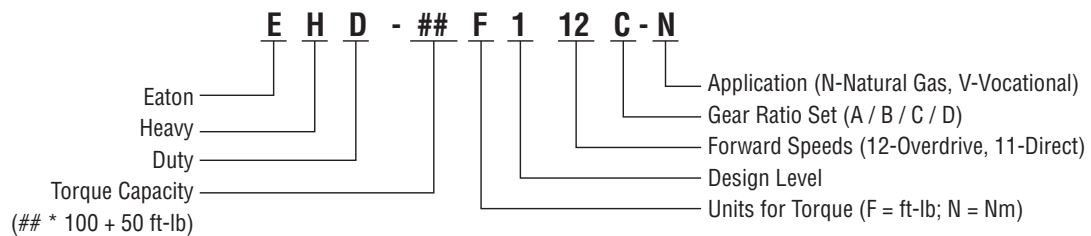
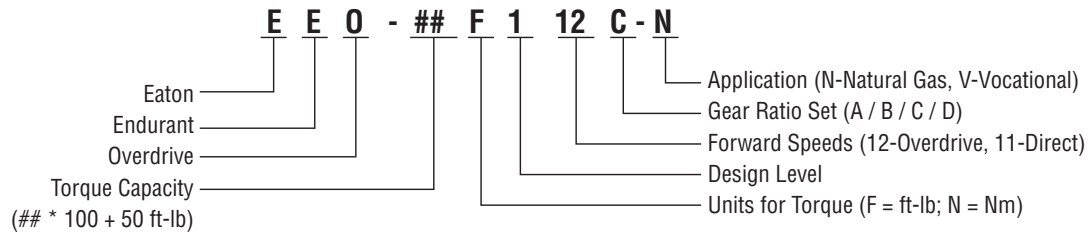

Serial Number

The serial number is the sequential identification number of the transmission. Before calling for service assistance, write the number down as it may be needed.

Oil

Special Instructions

- Perform the transmission fill procedure with transmission installed in vehicle to ensure proper transmission angle.
- Perform this procedure if transmission remained in-vehicle during service.

Special Tools

None

Component Identification

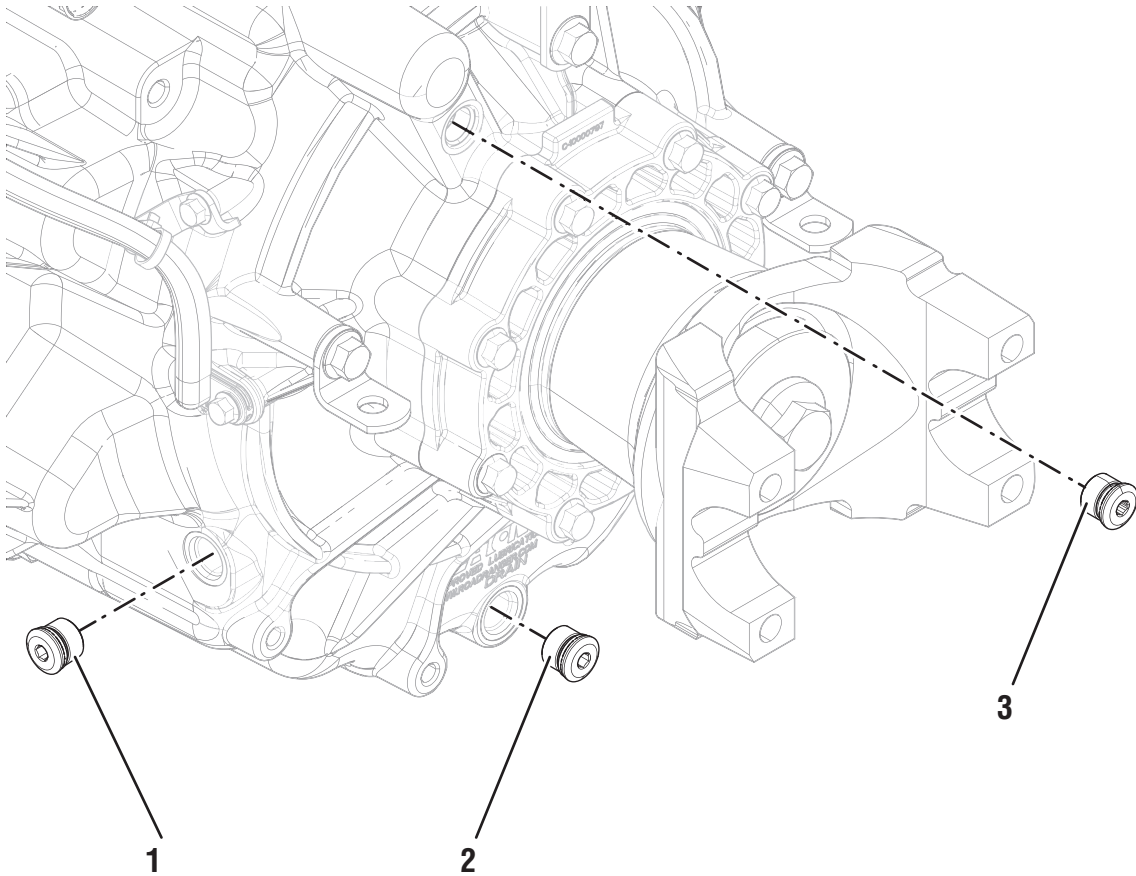

1. Oil Check Plug - 6 mm Hex
2. Oil Drain Plug - 6 mm Hex
3. Oil Fill Plug - 6 mm Hex

Drain Oil

1. Locate the Oil Drain Plug on the back of the rear housing.
2. Place a suitable container under the Oil Drain Plug.

Note: If reusing oil, use a clean container free of contamination and debris.

3. Remove the Oil Drain Plug with a 6 mm hex key and drain the oil.



4. If PTO-equipped, remove PTO and drain the oil.
5. Inspect Oil Drain Plug and O-ring for damage. If damaged, replace the Oil Drain Plug; O-ring is serviced with plug.
6. Install the Oil Drain Plug (6 mm) and torque to 24.5-29.5 Nm (18-22 lb-ft).

NOTICE: Do not over-torque drain plug or transmission damage may occur.

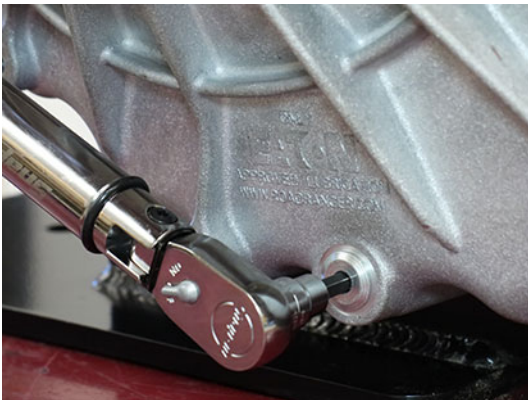

Fill Oil

Note: Perform the transmission fill procedure with transmission installed in vehicle to ensure proper transmission angle.

1. Remove the Oil Fill Plug with a 6 mm hex key.

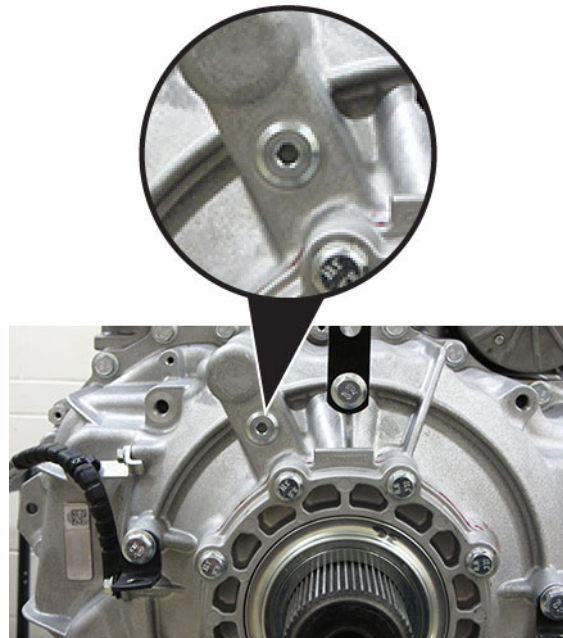

2. Place a suitable container under the Oil Check Plug and remove the Oil Check Plug with a 6 mm hex key.



3. Fill the transmission with PS-386 lube until a small amount of oil runs out of the Oil Check Plug hole.

Note: Fill capacity is approximately 7.5-8.5 liters (16-18 pints) depending on the transmission angle.

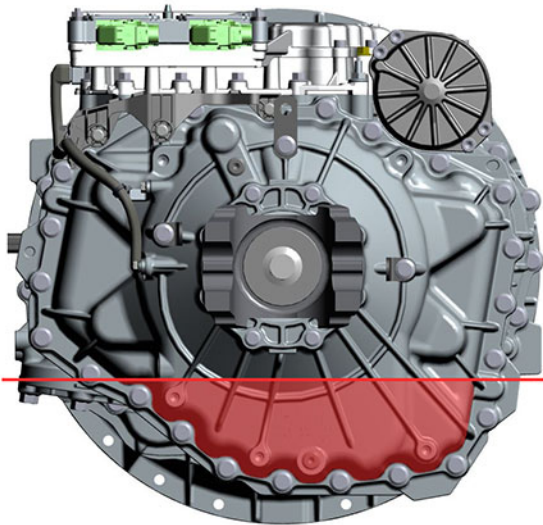
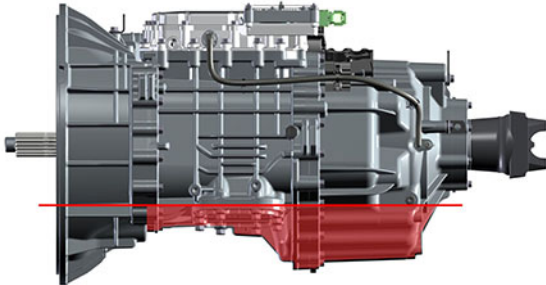

4. Inspect Oil Check Plug and O-ring for damage. If damaged, replace the Oil Check Plug; O-ring is serviced with plug.

5. Install the Oil Check Plug (6 mm) and torque to 24.5-29.5 Nm (18-22 lb-ft).

NOTICE: Do not over-torque the Oil Fill Plug or transmission damage may occur.



6. Inspect Oil Fill Plug and O-ring for damage. If damaged, replace the Oil Fill Plug; O-ring is serviced with plug.
7. Install the Oil Fill Plug (6 mm) and torque to 24.5-29.5 Nm (18-22 lb-ft).

NOTICE: Do not over-torque the Oil Fill Plug or transmission damage may occur.

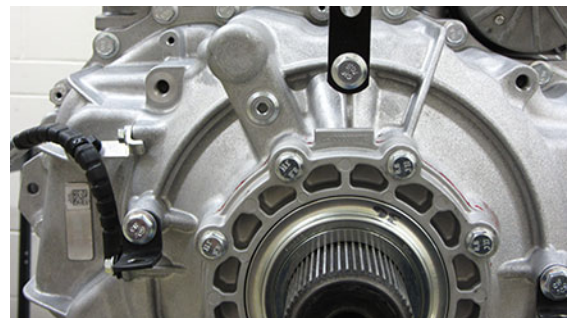

8. Inspect transmission for a PTO.
 - If not PTO-equipped, process complete.
 - If PTO-equipped, start the engine and run for 1 to 2 minutes to fill the PTO with oil, key off and repeat the Fill Oil Procedure.



CAUTION: Failure to repeat the Fill Oil service procedure to verify proper transmission oil level when equipped with a PTO may result in low transmission oil and component damage.

Linear Clutch Actuator (LCA)

Special Instructions

- The LCA can be removed and installed with the transmission in-vehicle.
- Drain the vehicle air system.
- Ensure Transmission Control Module (TCM) is fully powered down prior to LCA removal.

Special Tools

None

Component Identification

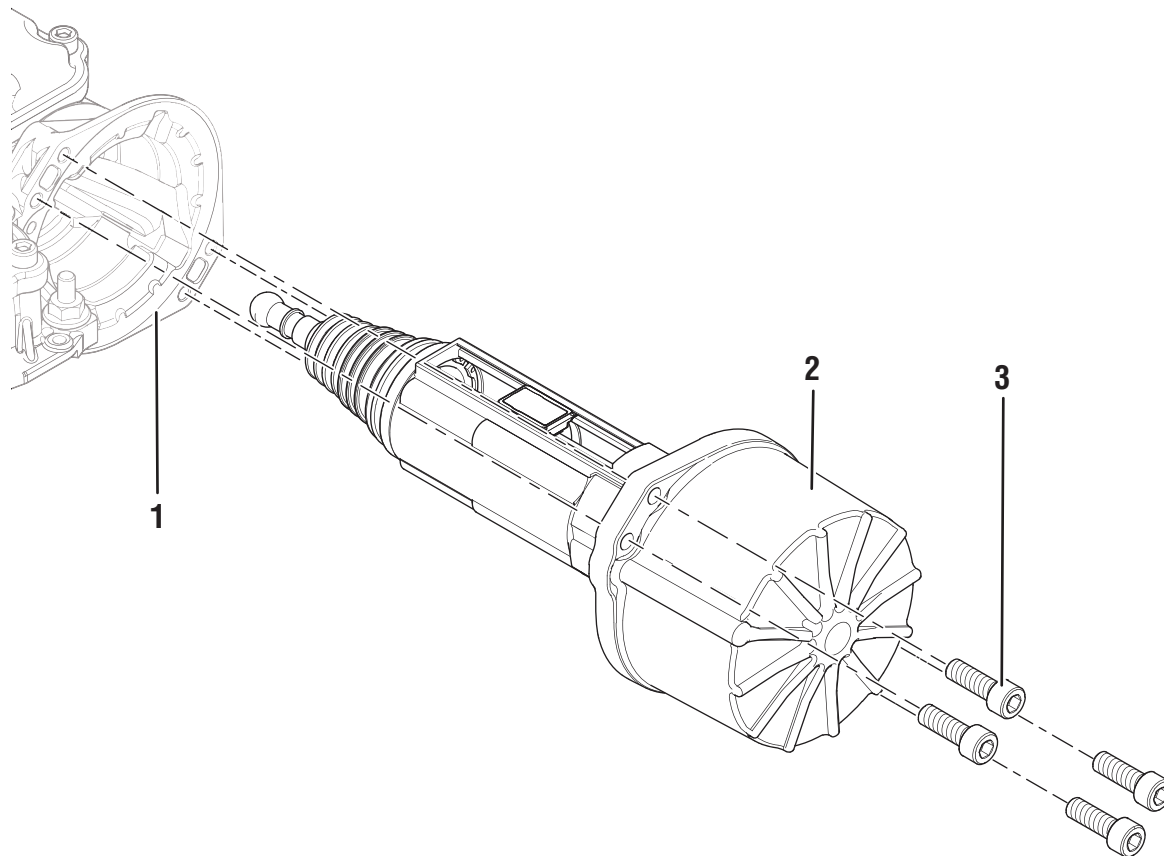

1. Mechatronic Transmission Module (MTM) Housing
2. Linear Clutch Actuator (LCA)
3. LCA Cap Screws (x4) - T45 Torx

Create a Service Activity Report

Note: If not already created and sent.

1. Key on with engine off.
2. Connect ServiceRanger and create a Service Activity Report.
3. Select "Send to Eaton" (internet connection required)
4. Disconnect ServiceRanger.
5. Key off.

Disconnect the Transmission Control Module (TCM)

1. Disconnect the negative battery cable.

NOTICE: Leaving battery cable connected may damage TCM.

2. Disconnect the 20-Way TCM Vehicle and Body Harness Connectors from the TCM by depressing the lock tab and lifting up on the lever.

NOTICE: Do not allow contamination into the connectors on the TCM.

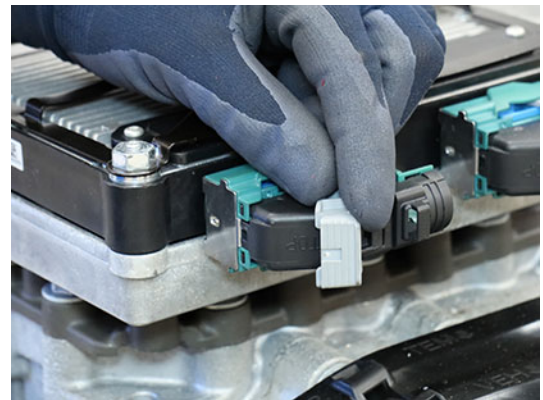

Allow the Transmission Control Module (TCM) to Power Down.

1. Wait 5 minutes to allow the TCM to fully power down prior to removal of the LCA.

NOTICE: Waiting 5 minutes ensures the TCM is fully powered down prior to LCA removal.

Remove the Linear Clutch Actuator (LCA)

1. Loosen the 4 LCA cap screws 1-2 turns each with a T45 Torx.

NOTICE: Ensure key is off, 20-Way TCM Vehicle and Body Harness Connectors are disconnected, and 5 minutes has passed prior to LCA removal.

Note: Residual air pressure in the LCA cylinder exhausts between the LCA and MTM housing when the cap screws are loosened.



2. Remove the 4 LCA cap screws
3. Remove the LCA from the MTM.

Note: LCA piston rod end is seated in the release yoke socket; pull to release rod end from socket.



- Inspect the plastic socket insert in the release yoke through the LCA opening using a flashlight to verify none of the fingers are missing or damaged.

Note: If the plastic insert is damaged, replace the release yoke assembly.

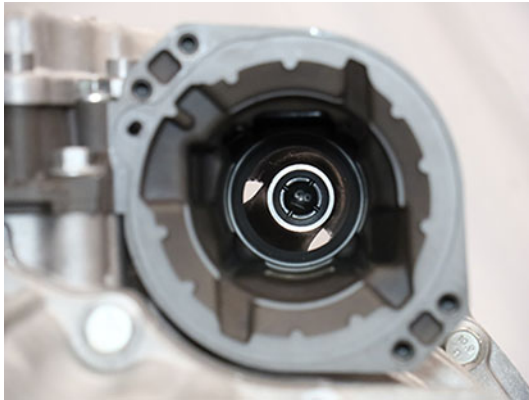

Reset and Install Linear Clutch Actuator (LCA)

- Inspect LCA to determine next steps, reference images below:
 - If LCA is locked in the reset position, go to Install Linear Clutch Actuator (LCA).
 - If LCA is not locked in the reset position, go to Step 2.

Locked in Reset Position

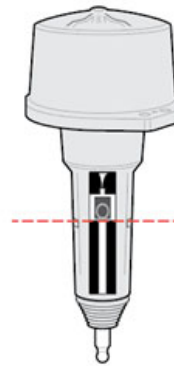

Not Locked in Reset Position

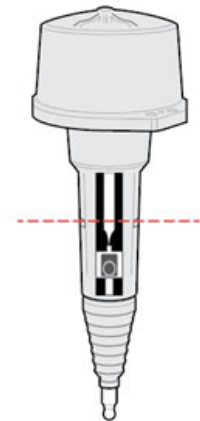

- Place LCA push rod on a clean, flat surface. Tightly grasp LCA housing with both hands and push down on push rod to lock LCA into the reset position.



CAUTION: A large amount of force is required to lock the LCA into the reset position. Failure to tightly grasp the LCA housing with both hands while pushing down on push rod may cause unintended movement resulting in personal injury and/or component damage.



3. Inspect LCA to determine next steps, reference images below:

- If LCA remains locked in the reset position, go to Step 4.
- If LCA does not remain locked in the reset position, go to Step 2, repeat reset procedure.

Note: If LCA cannot be locked into the reset position, replace LCA.



CAUTION: Do not drop LCA. Dropping LCA may cause the LCA to unlock resulting in personal injury and/or component damage.

Locked in Reset Position

Not Locked in Reset Position

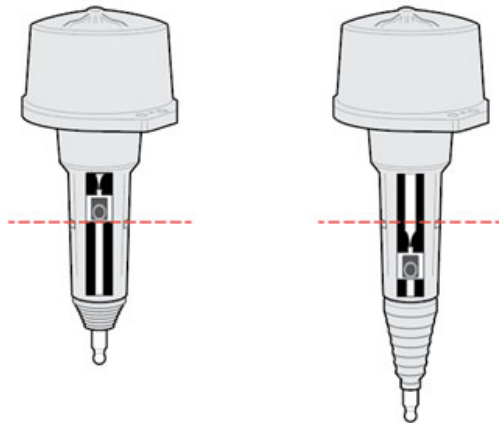

4. Clean all sealing surfaces on the MTM and LCA with a lint free cloth.

NOTICE: Do not use abrasive scrapers or powered tools to clean sealing surfaces or sealing surfaces may be damaged and leak.

5. Insert the LCA into the MTM.



6. Install 4 LCA T45 cap screws and torque to 23-28 Nm (17-21 lb-ft) in a criss-cross pattern.

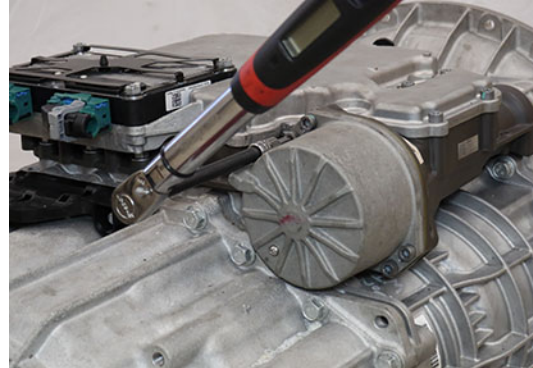

7. Determine next steps.

- If transmission is in-vehicle, go to “Connect the Transmission Control Module”.
- If transmission is out-of-vehicle, go to “Install the Release Bearing and Clutch Release Yoke” on page 121.

Connect the Transmission Control Module (TCM)

1. Connect the 20-Way TCM Vehicle and Body Harness Connector to the TCM by pressing the lever into the locked position.

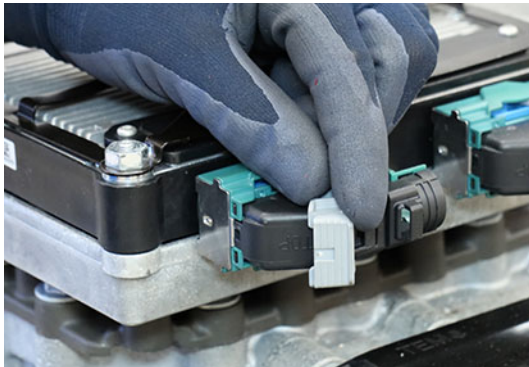

2. Connect the negative battery cable.

Clutch and Rail Calibration

To ensure proper operation, the TCM, clutch, MTM and transmission require a Clutch and Rail Calibration. Calibrations are automatically initiated when:

- LCA is in the reset position
- Transmission in "N" (Neutral)
- Key on engine running
- Vehicle air system pressure at operating range

NOTICE: Do not use service tool to initiate calibrations. Allow calibrations to automatically initiate.

Note: Vehicle display may indicate a flashing "CC" and "F" in gear display.

1. Set vehicle parking brake and chock wheels.
2. Ensure the driveline is connected between the transmission and axle.

Note: Clutch and Rail Calibrations cannot complete if the transmission output shaft is allowed to rotate.

3. Key on with engine running.
4. Allow vehicle air pressure to build to governor cut-off.

Note: Clutch and Rail Calibrations automatically initiate when vehicle air pressure reaches approximately 100 psi.

5. Ensure "N" (Neutral) is selected and engine is running. Wait approximately 2 minutes for calibrations to complete.

NOTICE: If process is interrupted, key off, wait 1 minute and go to **Step 2**.

- If vehicle display indicates a solid "N: (Neutral) in gear display, calibrations are complete. Key off, go to **Step 6**.
- If vehicle display continues to indicate a flashing "CC" and/or "F" in gear display or service transmission message, go to **Step 5**.

6. Key off and wait 1 minute.
7. Key on with engine off.
8. Connect ServiceRanger.
9. Go to “Fault Codes”.
 - If an Active transmission fault code is set, go to Endurant HD Troubleshooting Guide TRTS0950 **Diagnostic Procedure**.
 - If no Active transmission fault codes are set, select “Clear Eaton Faults” and follow on-screen prompts. Go to **Step 9**.
10. Disconnect ServiceRanger.
11. Key off.
12. Process complete.

Transmission Control Module (TCM)

Special Instructions

- The TCM can be removed and installed with transmission in-vehicle.
- If installing a replacement Transmission Assembly and/or MTM, after transmission is installed into vehicle, go to **Configure Transmission Control Module (TCM)**.
- If installing a new replacement TCM, go to “New Replacement Transmission Control Module (TCM) Service Procedure” on page 535.

Special Tools

- ServiceRanger

Component Identification

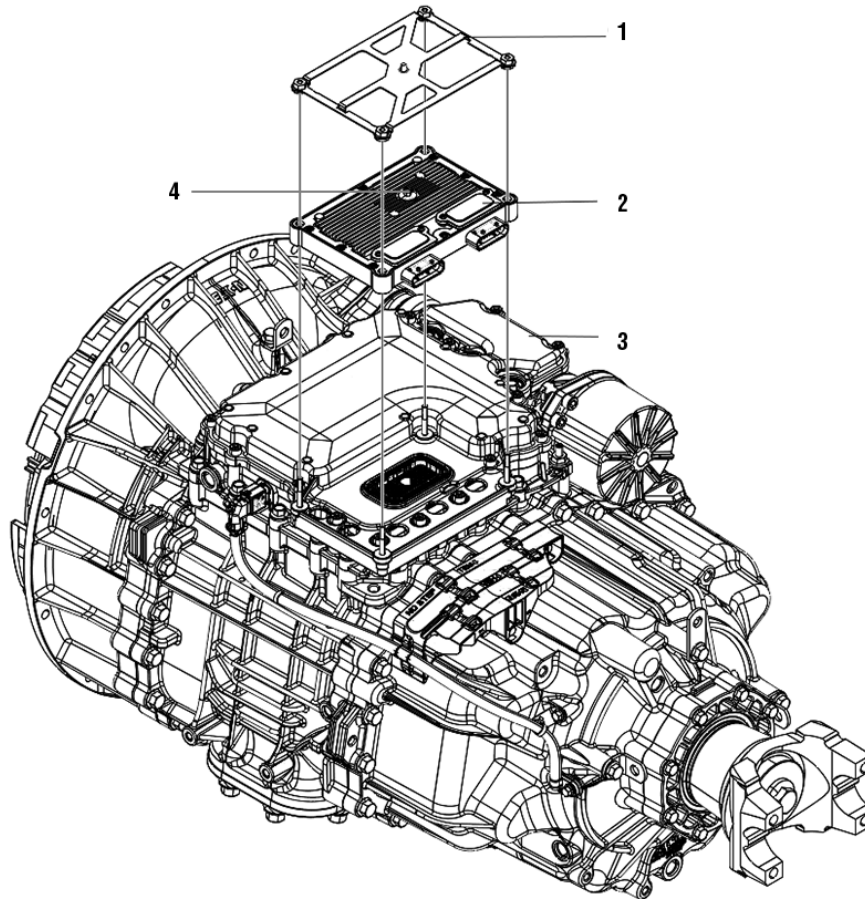

1. Transmission Control Module (TCM) Cover - 10 or 13 mm Nuts
2. Transmission Control Module (TCM)
3. Mechatronic Transmission Module (MTM)
4. Transmission Control Module (TCM) Jackscrew - 7 mm

Create a Service Activity Report

Note: If not already created and sent.

1. Key on with engine off.
2. Connect ServiceRanger and create a Service Activity Report.
3. Select "Send to Eaton" (internet connection required)
4. Disconnect ServiceRanger.
5. Key off.

Disconnect the Transmission Control Module (TCM)

1. Disconnect the negative battery cable.

NOTICE: Leaving battery cable connected may damage TCM.

2. Disconnect the 20-Way TCM Vehicle and Body Harness Connectors from the TCM by depressing the lock tab and lifting up on the lever.

NOTICE: Do not allow contamination into the connectors on the TCM.



Remove the Transmission Control Module (TCM)

1. Unscrew the 4 TCM Cover nuts and remove TCM Cover.

Note: TCM Cover nuts are 10 or 13 mm.



2. Unscrew the TCM 7 mm Jackscrew. Lift and remove the TCM from the MTM.

NOTICE: Do not allow contamination into the connectors on the TCM or MTM.



3. Inspect the TCM Seal for damage.

NOTICE: Replace the TCM Seal if damaged.

Note: If replacing the TCM, the REMAN TCM includes a new seal.



Install the Transmission Control Module (TCM)

NOTICE: Do not allow contamination into the connectors on the TCM or MTM.

Note: TCM can be installed with transmission in-vehicle.

1. Install the TCM Seal on the 74-Way Harness Connector.



2. Align the TCM to the 74-Way Harness Connector and TCM studs, then install the TCM.



3. Torque the TCM 7 mm Jackscrew to 3.0-4.0 Nm (26.6-35.4 lb-in).

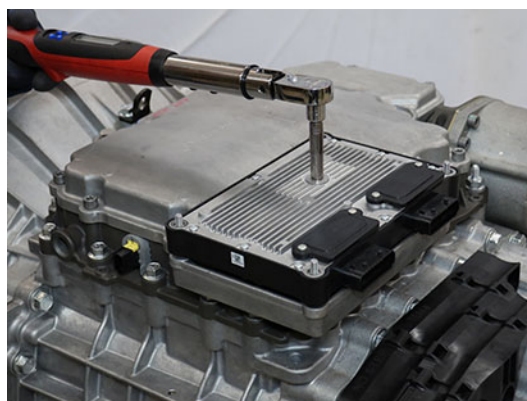

4. Install the TCM Cover over the 4 TCM studs and torque the 4 TCM Cover Nuts to 8.8-10.4 Nm (78-92 lb-in) in a criss-cross pattern.

Note: TCM Cover nuts are 10 or 13 mm.



Connect the Transmission Control Module (TCM)

1. Connect the 20-Way TCM Vehicle and Body Harness Connector to the TCM by pressing the lever into the locked position.

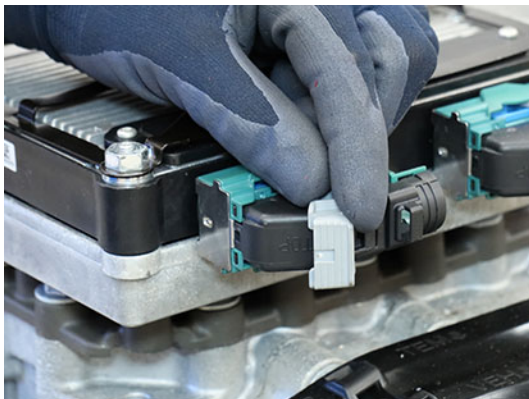

2. Connect the negative battery cable.

3. Determine next steps.
 - If re-installing original equipment TCM with transmission in vehicle, **process complete**.
 - If re-installing original equipment TCM with transmission removed from vehicle, go to “Remove the Linear Clutch Actuator” on page 11 follow with “Reset and Install Linear Clutch Actuator (LCA)” on page 12.

Note: If installing a new/replacement Transmission Assembly and/or MTM, after transmission is installed into vehicle, go to “Configure Transmission Control Module (TCM)” on page 21.

Configure Transmission Control Module (TCM)

Enter current transmission serial number and MTM serial number into TCM.

1. Record transmission serial number.

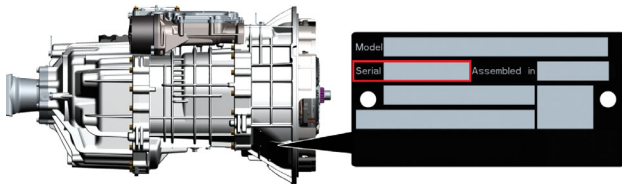

2. Record MTM serial number.

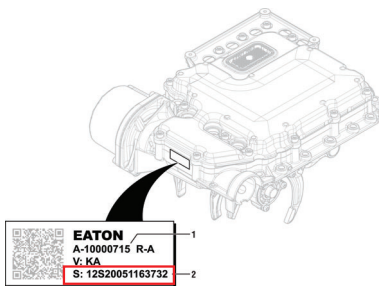

3. Key on with engine off.

Note: Vehicle display may indicate a flashing “F”, “CC”, or service transmission.

4. Connect ServiceRanger.
5. Go To “Configuration”.
6. Select “Identification”.

7. In the “Serial Number” parameter “New Value” field enter transmission serial number.
8. In the “Current MTM Serial Number” parameter “New Value” field enter MTM serial number.

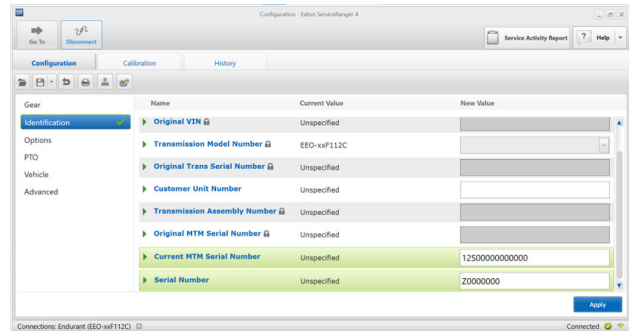

9. Select “Apply” and follow on-screen prompts.

Transmission

Special Instructions

- Create a Service Activity Report
NOTICE: A Service Activity Report is required for transmission and clutch warranty claims. Reference Service Bulletin TAIB-1012.
- Manually Vent Linear Clutch Actuator (LCA) prior to transmission removal.
- Perform LCA Reset Procedure prior to transmission installation.

Special Tools

- Transmission Jack Adapter Plate (RR1067TR)
- 2 cap screws and washers (M10 x 1.5 x 30 mm, minimum class 8.8)
- ServiceRanger

Component Identification

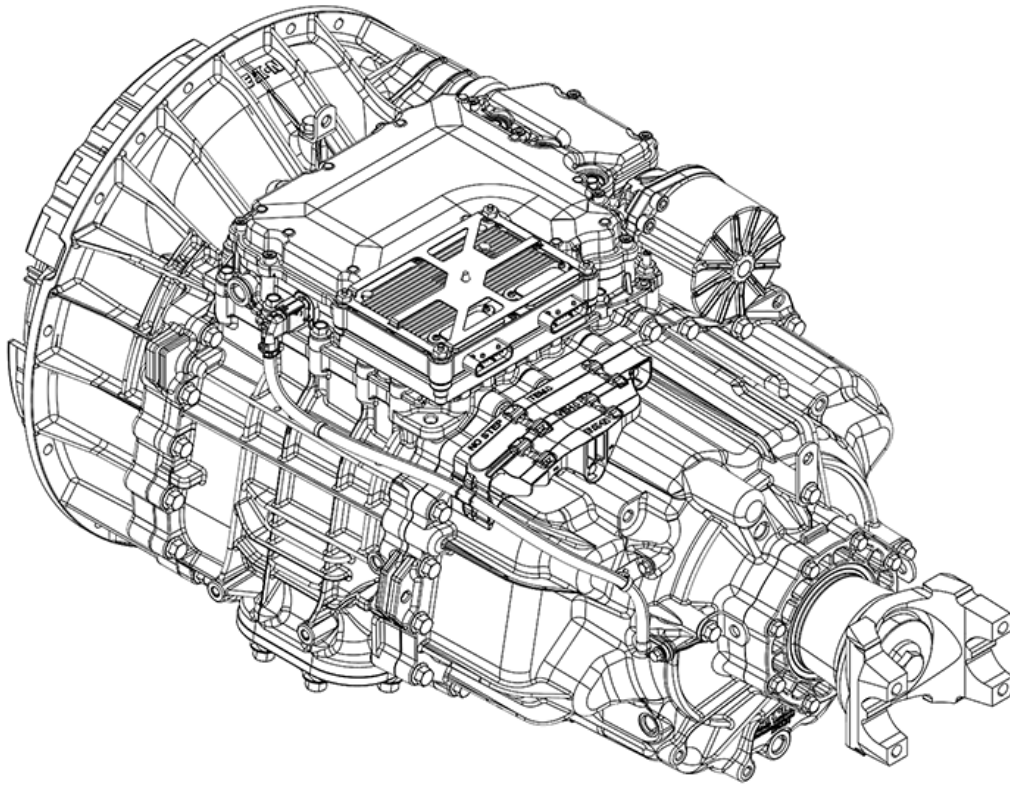

Create a Service Activity Report

Note: If not already created and sent.

1. Key on with engine off.
2. Connect ServiceRanger and create a Service Activity Report.
3. Select "Send to Eaton" (internet connection required)
4. Disconnect ServiceRanger.
5. Key off.

Manually Vent Linear Clutch Actuator (LCA)

1. Key off.
2. Set vehicle parking brake and chock wheels.

! **WARNING:** Apply vehicle parking brake and follow vehicle manufacture parking instructions. Failure to follow these instructions could cause unintended vehicle movement and may result in major vehicle component damage, severe injury or death.

3. Loosen the 4 Linear Clutch Actuator (LCA) cap screws 1-2 turns each with a T45 Torx.

Note: Residual air pressure in the LCA cylinder exhausts between the LCA and Mechatronic Transmission Module (MTM) housing when the cap screws are loosened.

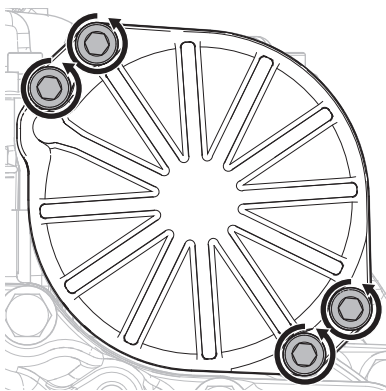

4. Tighten the 4 LCA to MTM T45 cap screws and torque to 23-27 Nm (17-21 lb-ft).

Drain Oil

1. Locate the Oil Drain Plug on the back of the rear housing.
2. Place a suitable container under the Oil Drain Plug.

Note: If reusing oil, use a clean container free of contamination and debris.

3. Remove the Oil Drain Plug with a 6 mm hex key and drain the oil.



4. If PTO-equipped, remove PTO and drain the oil.
5. Inspect Oil Drain Plug and O-ring for damage. If damaged, replace the Oil Drain Plug; O-ring is serviced with plug.
6. Install the Oil Drain Plug (6 mm) and torque to 24.5-29.5 Nm (18-22 lb-ft).

NOTICE: Do not over-torque drain plug or transmission damage may occur.

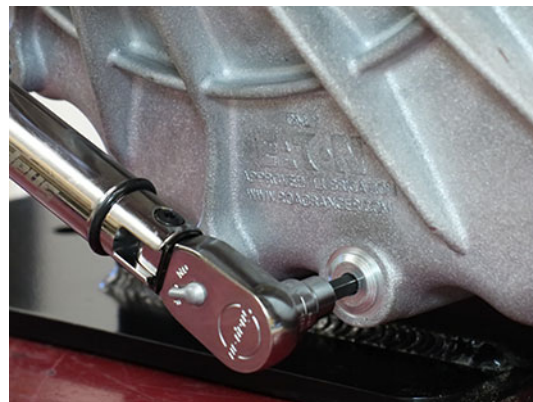

Remove the Transmission

1. Disconnect negative battery cable.
2. Refer to OEM guidelines for transmission removal.

Remove the Linear Clutch Actuator (LCA)

1. Loosen the 4 LCA cap screws 1-2 turns each with a T45 Torx.

NOTICE: Ensure key is off, 20-Way TCM Vehicle and Body Harness Connectors are disconnected, and 5 minutes has passed prior to LCA removal.

Note: Residual air pressure in the LCA cylinder exhausts between the LCA and MTM housing when the cap screws are loosened.



2. Remove the 4 LCA cap screws
3. Remove the LCA from the MTM.

Note: LCA piston rod end is seated in the release yoke socket; pull to release rod end from socket.



- Inspect the plastic socket insert in the release yoke through the LCA opening using a flashlight to verify none of the fingers are missing or damaged.

Note: If the plastic insert is damaged, replace the release yoke assembly.

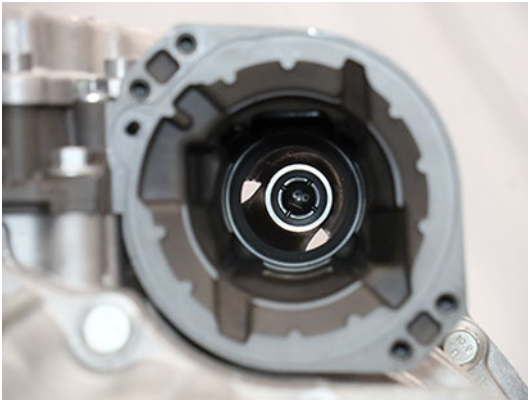

Reset and Install Linear Clutch Actuator (LCA)

- Inspect LCA to determine next steps, reference images below:
 - If LCA is locked in the reset position, go to Install Linear Clutch Actuator (LCA).
 - If LCA is not locked in the reset position, go to Step 2.

Locked in Reset Position

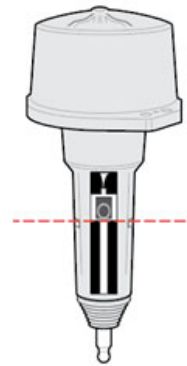

Not Locked in Reset Position

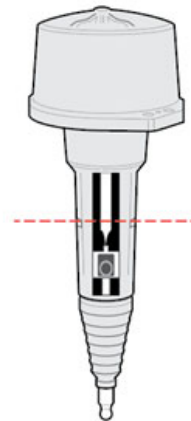

- Place LCA push rod on a clean, flat surface. Tightly grasp LCA housing with both hands and push down on push rod to lock LCA into the reset position.



CAUTION: A large amount of force is required to lock the LCA into the reset position. Failure to tightly grasp the LCA housing with both hands while pushing down on push rod may cause unintended movement resulting in personal injury and/or component damage.



3. Inspect LCA to determine next steps, reference images below:

- If LCA remains locked in the reset position, go to Step 4.
- If LCA does not remain locked in the reset position, go to Step 2, repeat reset procedure.

Note: If LCA cannot be locked into the reset position, replace LCA.



CAUTION: Do not drop LCA. Dropping LCA may cause the LCA to unlock resulting in personal injury and/or component damage.

Locked in Reset Position

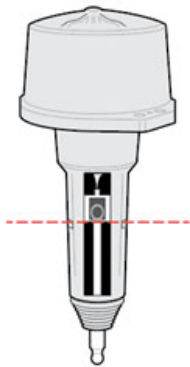

Not Locked in Reset Position

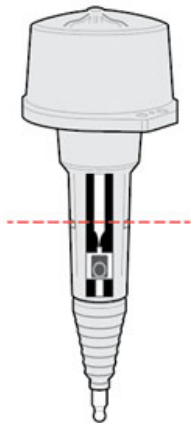

4. Clean all sealing surfaces on the MTM and LCA with a lint free cloth.

NOTICE: Do not use abrasive scrapers or powered tools to clean sealing surfaces or sealing surfaces may be damaged and leak.

5. Insert the LCA into the MTM.



6. Install 4 LCA T45 cap screws and torque to 23-28 Nm (17-21 lb-ft) in a criss-cross pattern.

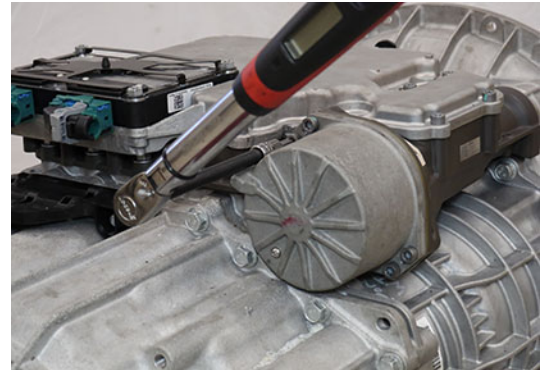

Install the Release Bearing and Clutch Release Yoke

1. Install the upper Release Yoke socket over the rod end of the Linear Clutch Actuator (LCA) and press until attached.



2. Install the lower Release Yoke socket over the lower pivot on the clutch housing and press until attached.



3. Slide the Release Bearing over the input shaft and into the Release Yoke.



Install the Transmission

1. Refer to OEM guidelines for transmission installation.
2. Connect negative battery cable.

Fill Oil

Note: Perform the transmission fill procedure with transmission installed in vehicle to ensure proper transmission angle.

1. Remove the Oil Fill Plug with a 6 mm hex key.

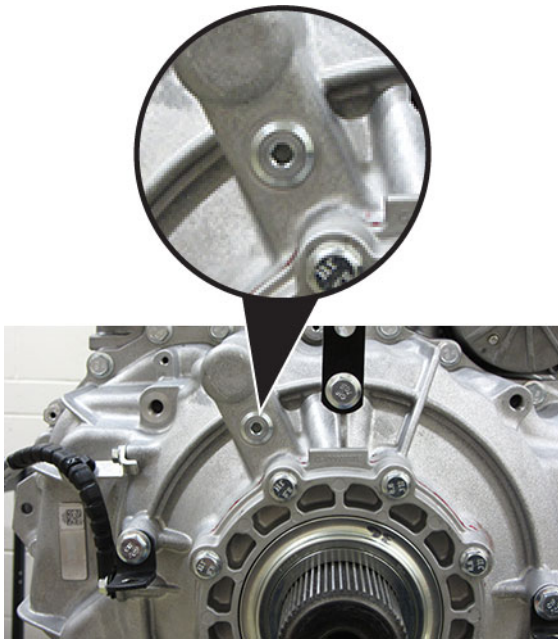

2. Place a suitable container under the Oil Check Plug and remove the Oil Check Plug with a 6 mm hex key.



3. Fill the transmission with PS-386 lube until a small amount of oil runs out of the Oil Check Plug hole.

Note: Fill capacity is approximately 7.5-8.5 liters (16-18 pints) depending on the transmission angle.

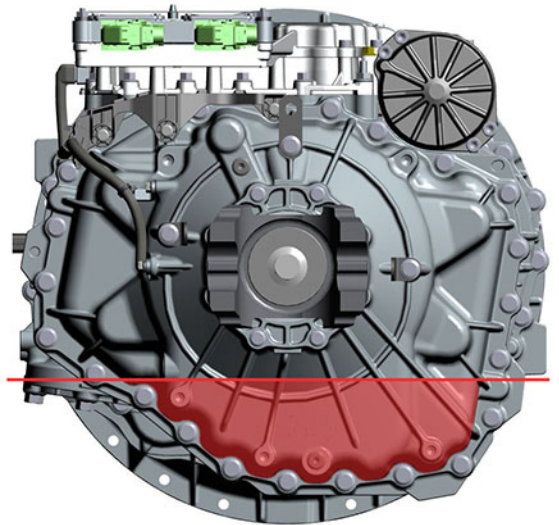
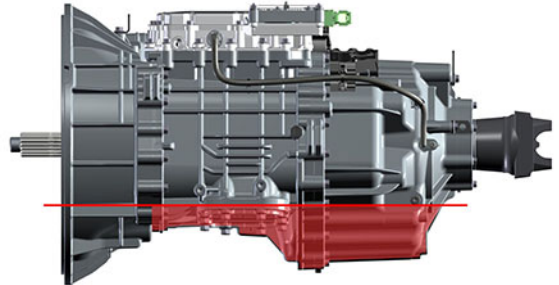

4. Inspect Oil Check Plug and O-ring for damage. If damaged, replace the Oil Check Plug; O-ring is serviced with plug.

5. Install the Oil Check Plug (6 mm) and torque to 24.5-29.5 Nm (18-22 lb-ft).

NOTICE: Do not over-torque the Oil Fill Plug or transmission damage may occur.



6. Inspect Oil Fill Plug and O-ring for damage. If damaged, replace the Oil Fill Plug; O-ring is serviced with plug.
7. Install the Oil Fill Plug (6 mm) and torque to 24.5-29.5 Nm (18-22 lb-ft).

NOTICE: Do not over-torque the Oil Fill Plug or transmission damage may occur.

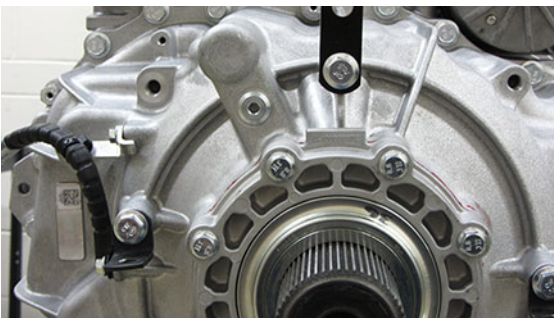

Clutch and Rail Calibration

To ensure proper operation, the TCM, clutch, MTM and transmission require a Clutch and Rail Calibration. Calibrations are automatically initiated when:

- LCA is in the reset position
- Transmission in “N” (Neutral)
- Key on engine running
- Vehicle air system pressure at operating range

NOTICE: Do not use service tool to initiate calibrations. Allow calibrations to automatically initiate.

Note: Vehicle display may indicate a flashing “CC” and “F” in gear display.

1. Set vehicle parking brake and chock wheels.
2. Ensure the driveline is connected between the transmission and axle.

Note: Clutch and Rail Calibrations cannot complete if the transmission output shaft is allowed to rotate.
3. Key on with engine running.
4. Allow vehicle air pressure to build to governor cut-off.

Note: Clutch and Rail Calibrations automatically initiate when vehicle air pressure reaches approximately 100 psi.
5. Ensure “N” (Neutral) is selected and engine is running. Wait approximately 2 minutes for calibrations to complete.

NOTICE: If process is interrupted, key off, wait 1 minute and go to **Step 2**.

 - If vehicle display indicates a solid “N: (Neutral) in gear display, calibrations are complete. Key off, go to **Step 6**.
 - If vehicle display continues to indicate a flashing “CC” and/or “F” in gear display or service transmission message, go to **Step 5**.
6. Key off and wait 1 minute.

7. Key on with engine off.
8. Connect ServiceRanger.
9. Go to “Fault Codes”.
 - If an Active transmission fault code is set, go to Endurant HD Troubleshooting Guide TRTS0950 **Diagnostic Procedure**.
 - If no Active transmission fault codes are set, select “Clear Eaton Faults” and follow on-screen prompts. Go to **Step 9**.
10. Disconnect ServiceRanger.
11. Key off.
12. Inspect transmission for a PTO.
 - If not PTO-equipped, process complete.
 - If PTO-equipped, start the engine and run for 1 to 2 minutes to fill the PTO with oil, key off and repeat the Fill Oil Procedure.



CAUTION: Failure to repeat the Fill Oil service procedure to verify proper transmission oil level when equipped with a PTO may result in low transmission oil and component damage.

Clutch

Special Instructions

Install Clutch Alignment Shaft (RR1087TR) onto a clutch jack. Refer to clutch jack manufacturer guidelines for proper installation instructions.



WARNING: Clutch weighs approximately 125 lbs. Failure to properly secure the Clutch Alignment Shaft to the clutch jack may result in clutch damage, severe injury or death.

NOTICE: For flywheel inspection and machining procedures, refer to OEM and/or engine manufacture.



CAUTION: Follow all OEM and/or engine manufacture flywheel inspection and machining procedures. Failure to follow OEM and/or engine manufacture flywheel procedures may result in the Clutch Cover not properly attaching or fully seating to the flywheel and cause:

- Fault Code 250 to set Active
- "CC" in display and may not complete a Clutch Calibration

Special Tools

- Clutch Installation Tool Kit (RR2000CL)
- 6 ounce (170 gram) hammer
- 3/8 inch (9.525 mm) brass pin punch (Starrett® B248E Pin Punch, Brass Drive 3/8" or equivalent)
- Input Shaft Pilot Bearing Wear Sleeve Puller (RR1062TR)
- Wear Sleeve Installer (RR1061TR)
- Snap Ring Installer (RR1061TR-1)
- Wear Sleeve Driver (RR1061TR-2)
- Vernier Caliper
- Steel straight edge 300mm (12 inch) long with a minimum thickness of 6.35mm (1/4 inch) - (12" Veritas Steel Straightedge or equivalent)

Component Identification

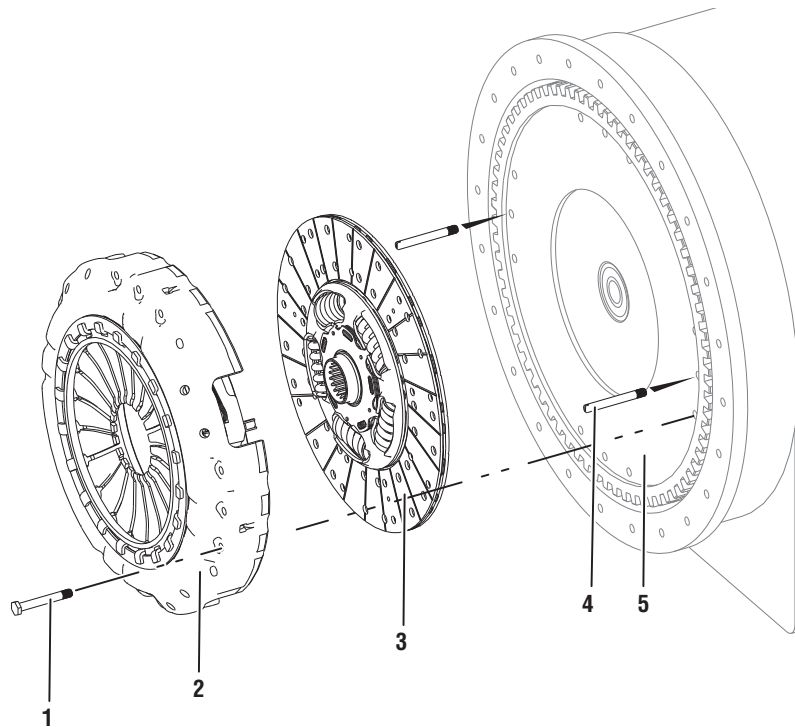

1. Clutch Cover Cap Screws (x12) M10 x 1.5 x 80mm, minimum class 10.9, flange type fasteners
2. Clutch Cover

3. Driven Disc Assembly
4. Alignment Pins (x2)
5. Engine Flywheel

Create a Service Activity Report

Note: If not already created and sent.

1. Key on with engine off.
2. Connect ServiceRanger and create a Service Activity Report.
3. Select "Send to Eaton" (internet connection required)
4. Disconnect ServiceRanger.
5. Key off.

Manually Vent Linear Clutch Actuator (LCA)

1. Key off.
2. Set vehicle parking brake and chock wheels.

! **WARNING:** Apply vehicle parking brake and follow vehicle manufacture parking instructions. Failure to follow these instructions could cause unintended vehicle movement and may result in major vehicle component damage, severe injury or death.

3. Loosen the 4 Linear Clutch Actuator (LCA) cap screws 1-2 turns each with a T45 Torx.

Note: Residual air pressure in the LCA cylinder exhausts between the LCA and Mechatronic Transmission Module (MTM) housing when the cap screws are loosened.

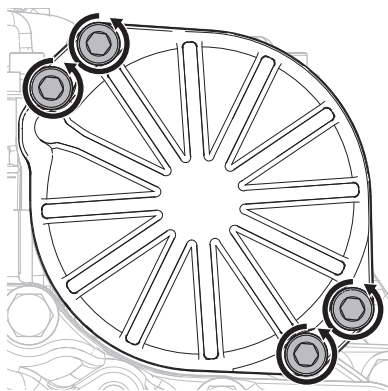

4. Tighten the 4 LCA to MTM T45 cap screws and torque to 23-27 Nm (17-21 lb-ft).

Remove the Transmission

1. Disconnect negative battery cable.
2. Refer to OEM guidelines for transmission removal.

Remove the Clutch

1. Remove the 4 center 15 mm Clutch Cover cap screws from each of the 3-bolt groups.



WARNING: Clutch weighs approximately 125 lbs. Failure to properly secure the Clutch Alignment Shaft to the clutch jack may result in clutch damage, severe injury or death.



2. Install and hand tighten the 4 stand-off bolts (RR1063TR-4) in place of the removed Clutch Cover cap screws.



3. Insert the clutch jack-mounted Clutch Alignment Shaft (RR1087TR) into the clutch diaphragm spring and pilot bearing.



WARNING: Clutch weighs approximately 125 lbs. Dropping clutch may result in damage to clutch, serious injury or death.



4. Remove the 8 remaining 15 mm Clutch Cover cap screws.

NOTICE: Do not remove the 4 stand-off bolts.

5. Remove the Clutch Cover and Driven Disc from the flywheel.

Engine Flywheel and Housing Inspection

NOTICE: For flywheel inspection and machining procedures, refer to OEM and/or engine manufacture.



CAUTION: Follow all OEM and/or engine manufacture flywheel inspection and machining procedures. Failure to follow OEM and/or engine manufacture flywheel procedures may result in the Clutch Cover to not properly attach or seat to the flywheel and cause:

- Fault Code 250 to set Active
- "CC" in display and may not complete a Clutch Calibration

1. Remove the pilot bearing.
2. Verify flywheel face runout.
3. Secure the dial indicator base to the flywheel housing face with the dial indicator finger in contact with the flywheel face near the outer diameter.

Note: Clean all dial indicator contact surfaces.

4. Rotate flywheel one revolution and record flywheel face runout: maximum runout is 0.008" (0.20 mm).

NOTICE: If any reading exceeds maximum runout, premature clutch wear will occur. Refer to OEM engine manufacture guidelines for repair or replacement.

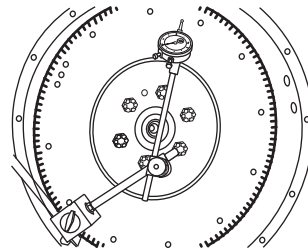

5. Verify pilot bearing bore runout.
6. Secure the dial indicator base to the flywheel housing face with the dial indicator finger in contact with the pilot bearing bore.

Note: Clean all dial indicator contact surfaces.

7. Rotate flywheel one revolution and record pilot bearing bore runout: maximum runout is 0.005" (0.13 mm).

NOTICE: If any reading exceeds maximum runout, premature clutch wear will occur. Refer to OEM engine manufacture guidelines for repair or replacement.

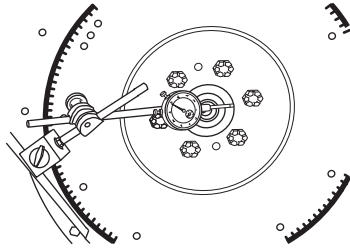

8. Verify flywheel housing inner diameter (ID) runout.
 9. Secure the dial indicator base to the crankshaft with the dial indicator finger in contact with the flywheel housing ID.
- Note:** Clean all dial indicator contact surfaces.
10. Rotate crankshaft one revolution and record flywheel housing (ID) runout: maximum runout is 0.008" (0.20 mm).

NOTICE: If any reading exceeds maximum, runout premature clutch wear will occur, Refer to OEM engine manufacture guidelines for repair or replacement.

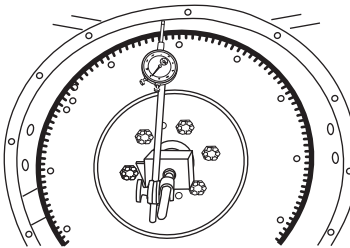

11. Verify flywheel housing face runout.
 12. Secure the dial indicator base to the flywheel face near the outer diameter with the dial indicator finger in contact with the face of the flywheel housing.
- Note:** Clean all dial indicator contact surfaces.
13. Rotate flywheel one revolution and record flywheel housing face runout: maximum runout is 0.008" (0.20 mm).

NOTICE: If any reading exceeds maximum, runout premature clutch wear will occur. Refer to OEM engine manufacture guidelines for repair or replacement.

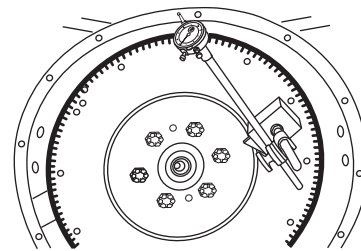

Install the Clutch

1. Install a new pilot bearing. Refer to OEM and/or engine manufacturer installation guidelines.
2. Install 2 Alignment Pins (RR1063TR-3) into the flywheel directly across from each other, at approximately 3 and 9 o'clock.

Note: Do not install the Alignment Pins into the center threaded hole of the 3-threaded hole groups.

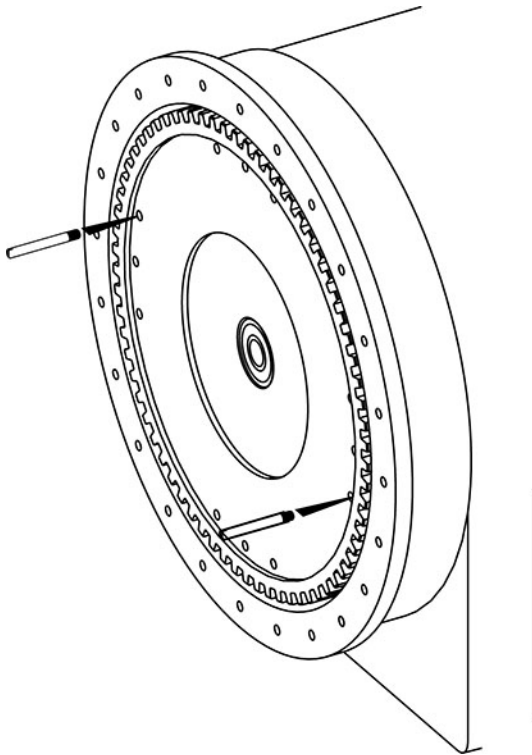

3. Install the Clutch Cover and Driven Disc onto the clutch jack-mounted Clutch Alignment Shaft (RR1087TR).



WARNING: Clutch weighs approximately 125 lbs. Failure to properly secure the Clutch Alignment Shaft to the clutch jack may result in clutch damage, severe injury or death.

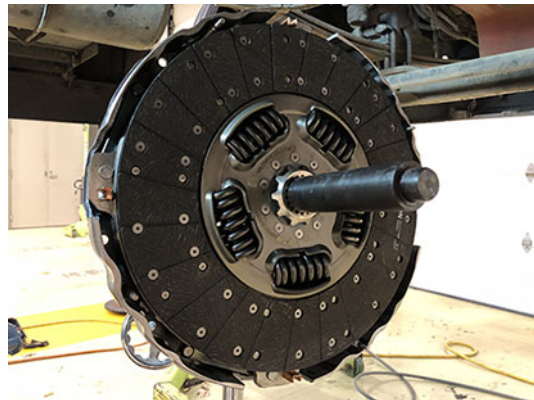

4. Align the Clutch Cover to the flywheel Alignment Pins and insert the Clutch Alignment Shaft (RR1087TR) into the Pilot Bearing.

- Slide Clutch Cover and Driven Disc on to the flywheel and install 6 Clutch Cover cap screws at the 5, 6, 7, 10, 11 and 12 positions (refer to cap screw callout image below). Torque finger tight plus 1/2 rotation clockwise.

NOTICE: Ensure clutch cover is fully seated into pilot lip on the flywheel rim at the 6 o'clock position.



CAUTION: Use only M10 x 1.5 x 80mm, minimum class 10.9, flange type fasteners for the Clutch Cover cap screws.

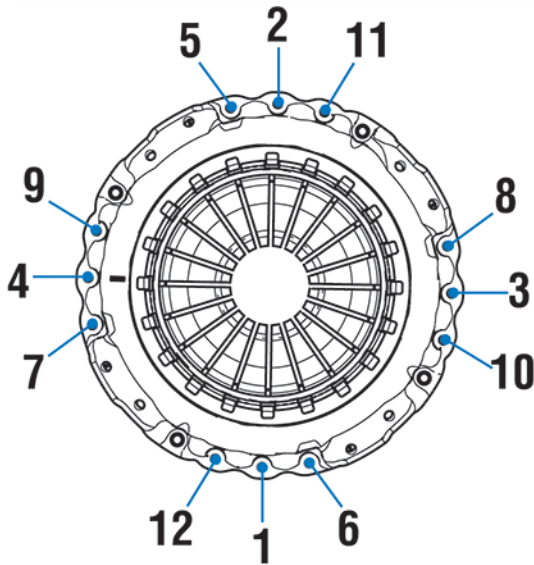

- Remove the Clutch Alignment Shaft (RR1087TR).



- Remove the 2 Alignment Pins (RR1063TR-3), 4 stand-off bolts (RR1063TR-4) and straps (if equipped) from the Clutch Cover.

- Install 6 remaining Clutch Cover cap screws finger tight.
- Torque Clutch Cover cap screws 1 through 4 to 30 Nm (23 lb-ft) as shown in the torque sequence below.



CAUTION: Reference cap screw call out images for proper torque sequence. Failure to follow the torque sequence may result in component damage.

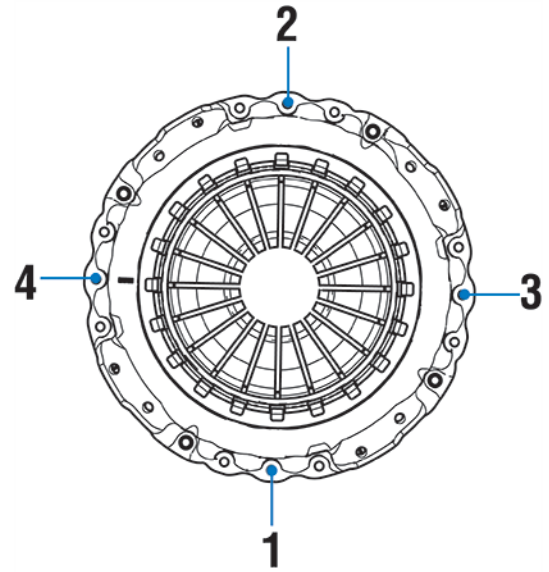

- Torque Clutch Cover cap screws 5 through 12 to 30 Nm (23 lb-ft) as shown in the torque sequence below.

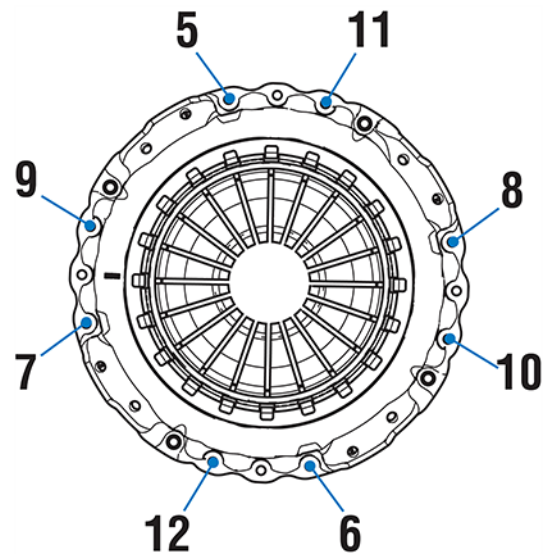

11. Torque Clutch Cover cap screws 1 through 12 to 57-67 Nm (42-50 lb-ft) as shown in the torque sequence below.

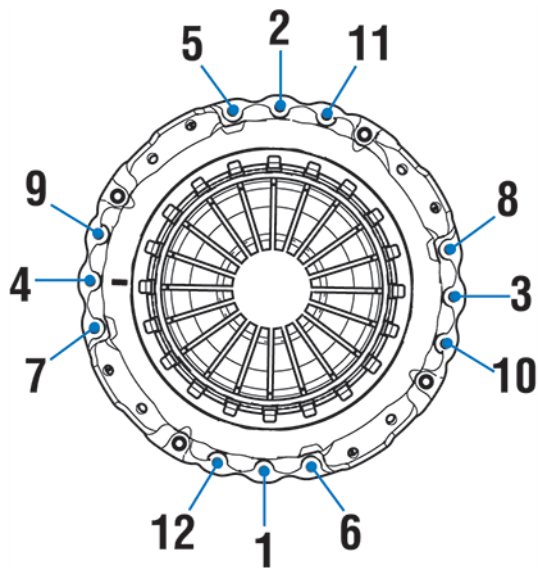

12. Re-torque Clutch Cover cap screws 1 through 12 to 57-67 Nm (42-50 lb-ft) as shown in the torque sequence below to verify clutch is fully seated to the flywheel.

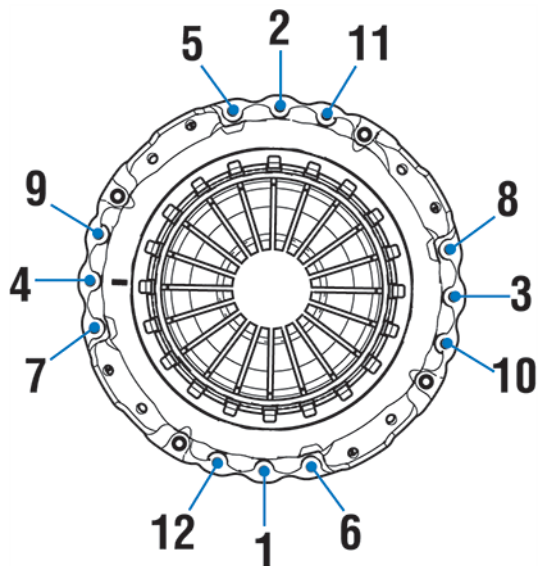

13. Locate the 4 Control Fingers in the Clutch Cover.

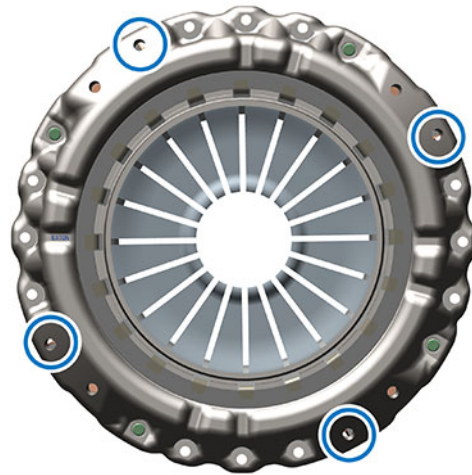

14. Use a 6 ounce (170 gram) hammer and a 3/8 inch (9.525 mm) brass pin punch and lightly tap the 4 control fingers until they contact the flywheel.



CAUTION: Keep fingers clear to avoid personal injury.

NOTICE: Only use tools specified and do not use excessive force to seat the control fingers to the flywheel. If controls fingers are damaged during installation the clutch will not properly adjust and will require replacement.

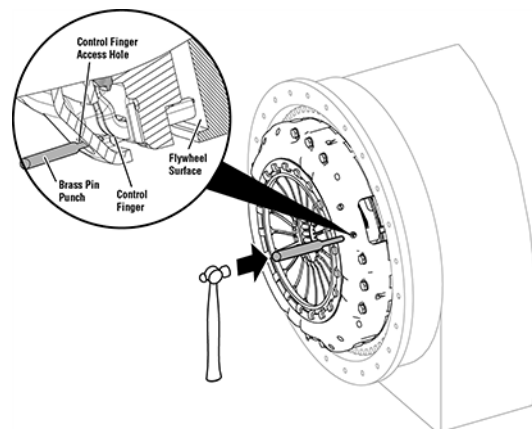

Measure Diaphragm Spring Finger Height

Special Tools

- Vernier Caliper
- Steel straight edge 300mm (12 inch) long with a minimum thickness of 6.35mm (1/4 inch)

1. Zero caliper to straight edge thickness.

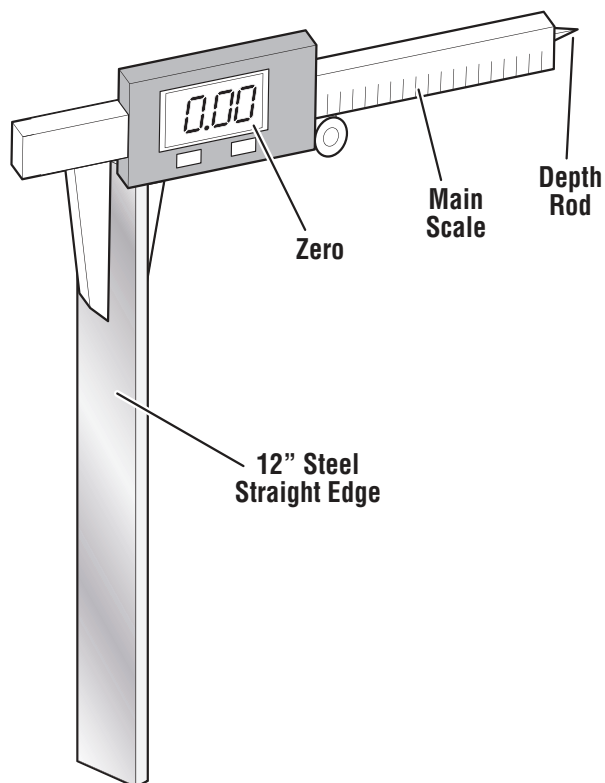

3. Place caliper "main scale" on straight edge and extend caliper "depth rod" toward one diaphragm spring tip.

Note: Ensure straight-edge is seated flat on inner-ring and not contacting other parts of the clutch cover. Ensure caliper is perpendicular to straight edge. Finger height must be measured at 4 locations.

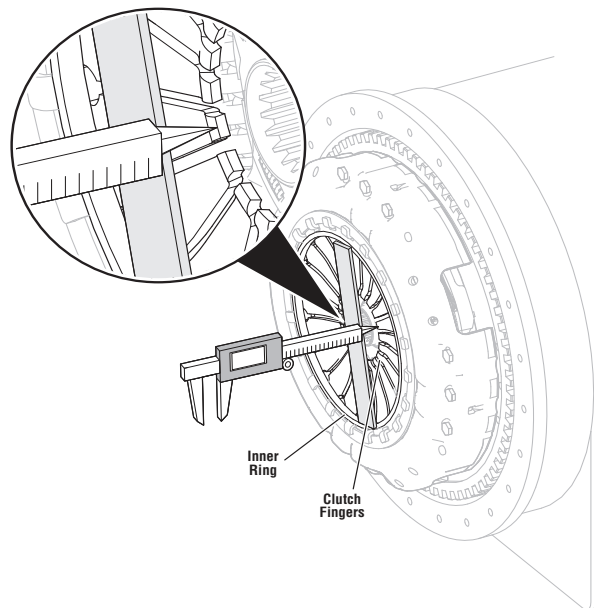

2. Place straight edge across clutch cover inner-ring.

Note: Ensure straight-edge is seated flat on inner-ring and not contacting other parts of the clutch cover.

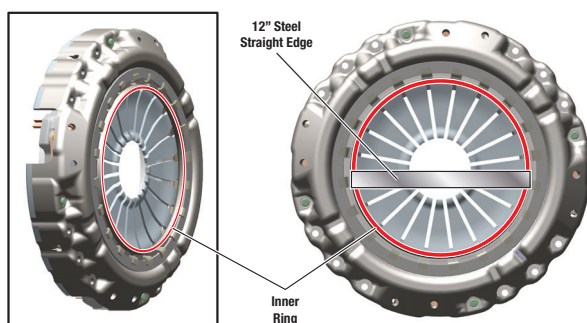

4. Record finger height measurements at 4 locations.
 - a. Record reading in table - Measurement 1.
 - b. For Measurement 2, place caliper "main scale" on straight edge 180 degrees from Measurement 1. Record reading in table - Measurement 2.
 - c. Repeat this process with the straight edge perpendicular and record reading in table - Measurement 3.
 - d. For Measurement 4, place caliper "main scale" on straight edge 180 degrees from Measurement 3. Record reading in table - Measurement 4.

Note: Ensure straight-edge is seated flat on inner-ring and not contacting other parts of the clutch cover. Ensure caliper is perpendicular to straight edge. Finger height must be measured in all 4 locations as illustrated.

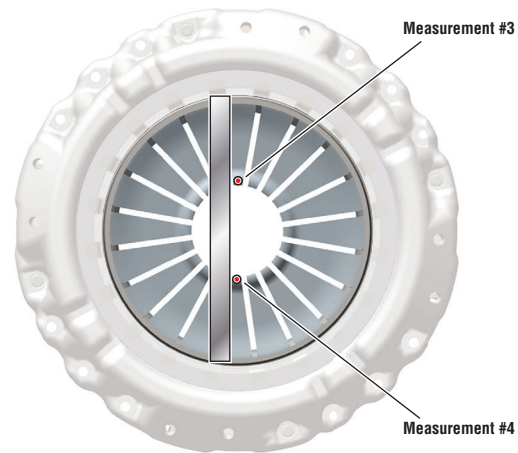
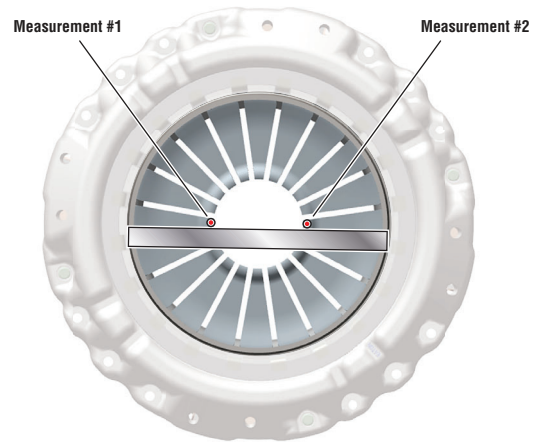

| Calculate Average Finger Height | |
|---------------------------------|---------|
| Measurement Position | Reading |
| 1 | |
| 2 | + |
| 3 | + |
| 4 | + |
| Total | = |
| Total divided by 4 | ÷ 4 |
| Average Finger Height | = |

5. Record engine manufacturer.
 - For all Cummins engines, go to Step 6.
 - For all other engines (not Cummins), go to Step 7.

6. Record Average Finger Height calculated in Step 4 and compare reading(s) in table based on clutch condition.
 - If readings are in range, process complete.
 - If readings are out of range, contact Eaton Cummins Automated Transmission Technologies at +1-800-826-4357 for further diagnostic instructions.



CAUTION: If the flywheel was resurfaced, ensure OEM and/or engine manufacture flywheel inspection and machining procedures were followed. Failure to follow OEM and/or engine manufacture flywheel procedures may result in the Clutch Cover not properly attaching or fully seating to the flywheel.

NOTICE: If the flywheel was replaced, ensure the correct flywheel part number was installed, refer to OEM and/or engine manufacturer.

| Cummins Engines | |
|--|---|
| Clutch Condition | Finger Height |
| <i>New Install</i> | <i>17mm - 21mm (0.669 - 0.827 inch)</i> |
| <i>Less than 160,934 km (100,000 miles)</i> | <i>17mm - 22mm (0.669 - 0.866 inch)</i> |
| <i>Greater than 160,934 km (100,000 miles)</i> | <i>17mm - 24mm (0.669 - 0.944 inch)</i> |

7. Record Average Finger Height calculated in Step 4 and compare reading(s) in table based on clutch condition.
 - If readings are in range, process complete.
 - If readings are out of range, contact Eaton Cummins Automated Transmission Technologies at +1-800-826-4357 for further diagnostic instructions.

NOTICE: If the flywheel was replaced, ensure the correct flywheel part number was installed, refer to OEM and/or engine manufacturer.

| All other engines (not Cummins) | |
|--|---|
| Clutch Condition | Finger Height |
| <i>New Install</i> | <i>15mm - 21mm (0.591 - 0.827 inch)</i> |
| <i>Less than 160,934 km (100,000 miles)</i> | <i>15mm - 22mm (0.591 - 0.866 inch)</i> |
| <i>Greater than 160,934 km (100,000 miles)</i> | <i>15mm - 24mm (0.591 - 0.944 inch)</i> |

Disassemble the Input Shaft Pilot Bearing Wear Sleeve

1. Remove the Spiral Snap Ring from the input shaft with a pick.



2. Install the Input Shaft Pilot Bearing Wear Sleeve Puller (RR1062TR) over the flats on the Pilot Bearing Wear Sleeve.



3. Tighten the 13 mm jackscrew on the Input Shaft Pilot Bearing Wear Sleeve Puller (RR1062TR) to remove Wear Sleeve.

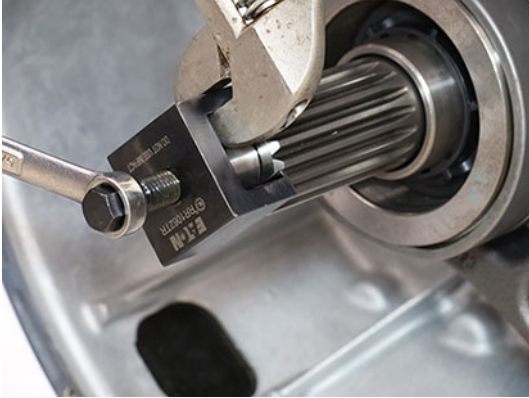

4. Remove the Wear Sleeve Alignment Pin.



Assemble the Input Shaft Pilot Bearing Wear Sleeve

1. Clean the Pilot Bearing Wear Sleeve surfaces on the input shaft.
2. Apply grease to alignment pin groove on the input shaft to hold the Wear Sleeve Alignment Pin in place.

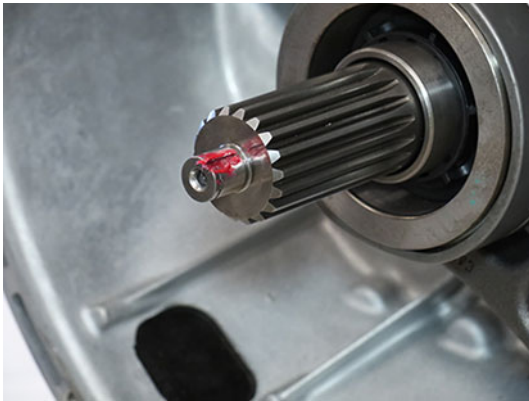

3. Slide the Wear Sleeve Alignment Pin into the groove on the input shaft.

NOTICE: Chamfered end of alignment pin must face forward.

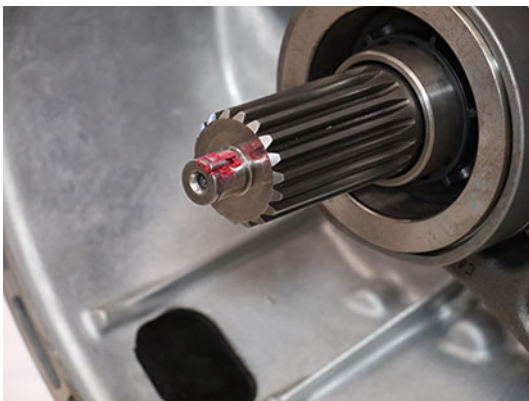

4. Align the groove in the Pilot Bearing Wear Sleeve with the Wear Sleeve Alignment Pin.



5. Hold the Pilot Bearing Wear Sleeve against the input shaft and lightly tap with a soft-faced hammer to start installation.



CAUTION: Keep fingers clear to avoid personal injury.

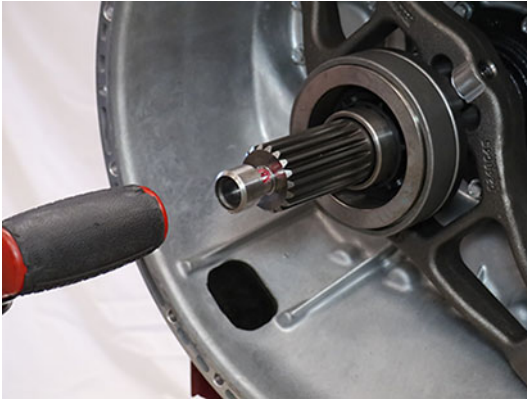

6. Use the Wear Sleeve Driver (RR1061TR-2) to fully seat the Pilot Bearing Wear Sleeve onto the input shaft.



7. Inspect the Pilot Bearing Wear Sleeve to ensure it is fully seated on the input shaft.

NOTICE: If there is a gap between the Pilot Bearing Wear Sleeve and the input shaft, the Wear Sleeve Alignment Pin may have moved out of the groove; remove the Pilot Bearing Wear Sleeve and re-perform assembly procedure.

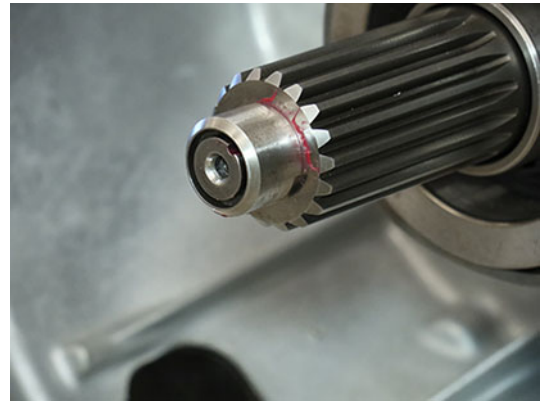

8. Install a new Spiral Snap Ring onto the Snap Ring Installer (RR1061TR-1).



- Slide the Wear Sleeve Driver (RR1061TR-2) over the Snap Ring Installer (RR1061TR-1).



- While holding the Snap Ring Installer (RR1061TR-1) against the input shaft, slide the Wear Sleeve Driver (RR1061TR-2) forward and fully seat the Spiral Snap Ring into the snap ring groove.

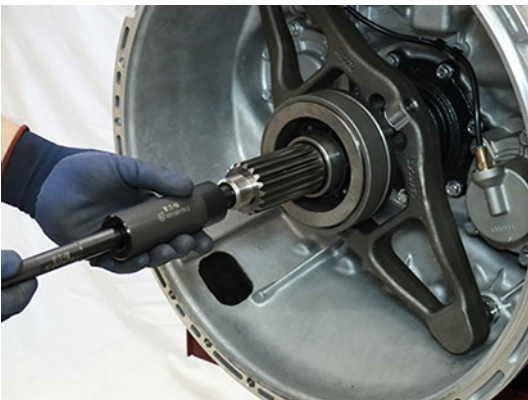

Remove the Linear Clutch Actuator (LCA)

- Loosen the 4 LCA cap screws 1-2 turns each with a T45 Torx.

NOTICE: Ensure key is off, 20-Way TCM Vehicle and Body Harness Connectors are disconnected, and 5 minutes has passed prior to LCA removal.

Note: Residual air pressure in the LCA cylinder exhausts between the LCA and MTM housing when the cap screws are loosened.



- Remove the 4 LCA cap screws
- Remove the LCA from the MTM.

Note: LCA piston rod end is seated in the release yoke socket; pull to release rod end from socket.



- Inspect the plastic socket insert in the release yoke through the LCA opening using a flashlight to verify none of the fingers are missing or damaged.

Note: If the plastic insert is damaged, replace the release yoke assembly.

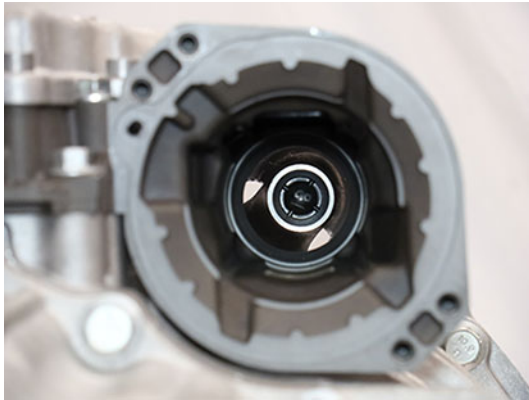

Reset and Install Linear Clutch Actuator (LCA)

- Inspect LCA to determine next steps, reference images below:
 - If LCA is locked in the reset position, go to Install Linear Clutch Actuator (LCA).
 - If LCA is not locked in the reset position, go to Step 2.

Locked in Reset Position

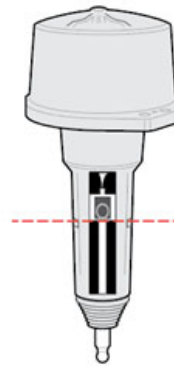

Not Locked in Reset Position

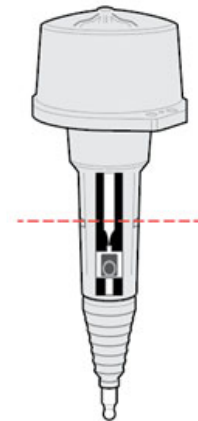

- Place LCA push rod on a clean, flat surface. Tightly grasp LCA housing with both hands and push down on push rod to lock LCA into the reset position.



CAUTION: A large amount of force is required to lock the LCA into the reset position. Failure to tightly grasp the LCA housing with both hands while pushing down on push rod may cause unintended movement resulting in personal injury and/or component damage.



3. Inspect LCA to determine next steps, reference images below:

- If LCA remains locked in the reset position, go to Step 4.
- If LCA does not remain locked in the reset position, go to Step 2, repeat reset procedure.

Note: If LCA cannot be locked into the reset position, replace LCA.



CAUTION: Do not drop LCA. Dropping LCA may cause the LCA to unlock resulting in personal injury and/or component damage.

Locked in Reset Position

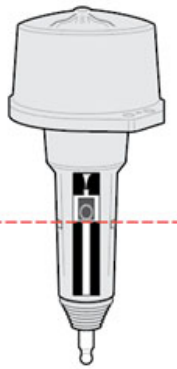

Not Locked in Reset Position

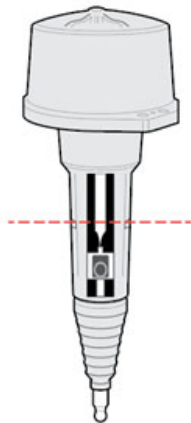

4. Clean all sealing surfaces on the MTM and LCA with a lint free cloth.

NOTICE: Do not use abrasive scrapers or powered tools to clean sealing surfaces or sealing surfaces may be damaged and leak.

5. Insert the LCA into the MTM.



6. Install 4 LCA T45 cap screws and torque to 23-28 Nm (17-21 lb-ft) in a criss-cross pattern.

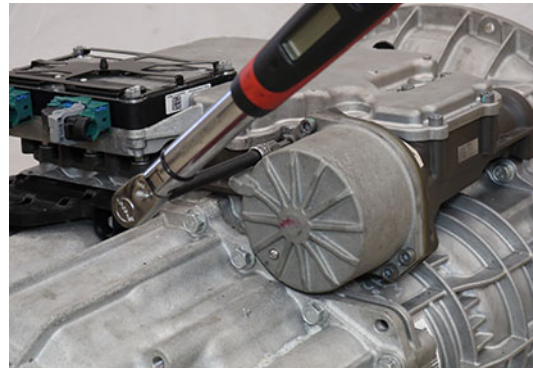

Install the Release Bearing and Clutch Release Yoke

1. Install the upper Release Yoke socket over the rod end of the Linear Clutch Actuator (LCA) and press until attached.



2. Install the lower Release Yoke socket over the lower pivot on the clutch housing and press until attached.



3. Slide the Release Bearing over the input shaft and into the Release Yoke.



Install the Transmission

1. Refer to OEM guidelines for transmission installation.
2. Connect negative battery cable.
3. Determine next step.
 - If transmission oil was **not** drained, go to Clutch and Rail Calibration.
 - If transmission oil was drained, go to Fill Oil.

Fill Oil

Note: Perform the transmission fill procedure with transmission installed in vehicle to ensure proper transmission angle.

1. Remove the Oil Fill Plug with a 6 mm hex key.

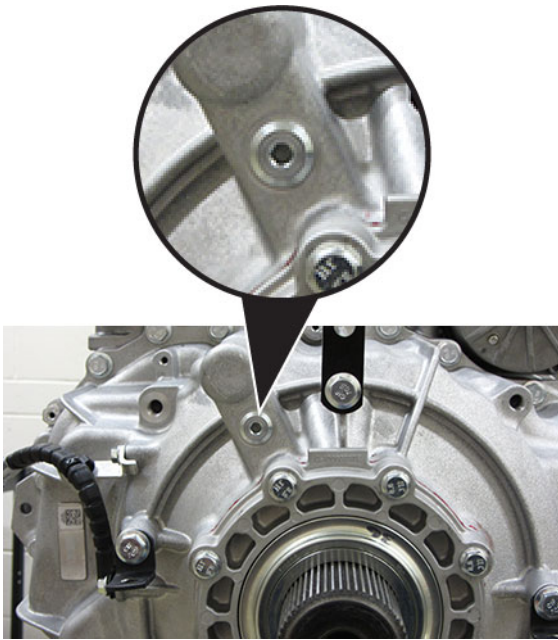

2. Place a suitable container under the Oil Check Plug and remove the Oil Check Plug with a 6 mm hex key.



3. Fill the transmission with PS-386 lube until a small amount of oil runs out of the Oil Check Plug hole.

Note: Fill capacity is approximately 7.5-8.5 liters (16-18 pints) depending on the transmission angle.

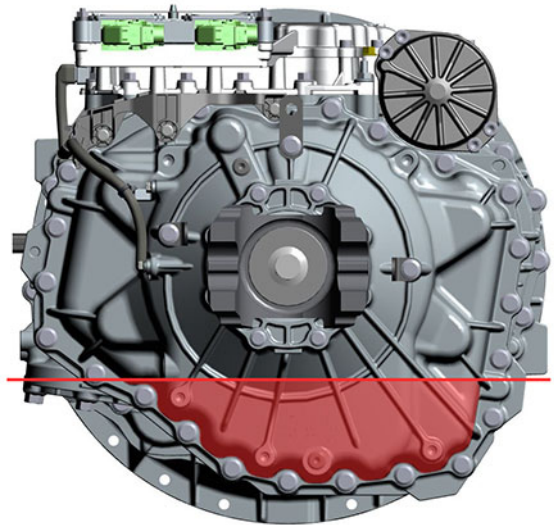
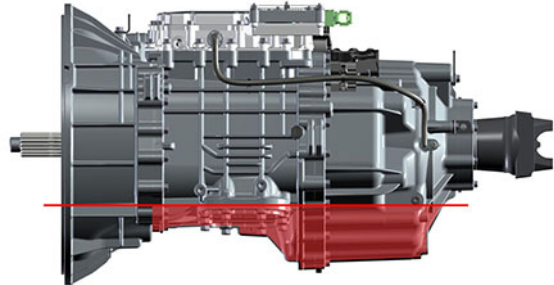

4. Inspect Oil Check Plug and O-ring for damage. If damaged, replace the Oil Check Plug; O-ring is serviced with plug.

5. Install the Oil Check Plug (6 mm) and torque to 24.5-29.5 Nm (18-22 lb-ft).

NOTICE: Do not over-torque the Oil Fill Plug or transmission damage may occur.



6. Inspect Oil Fill Plug and O-ring for damage. If damaged, replace the Oil Fill Plug; O-ring is serviced with plug.
7. Install the Oil Fill Plug (6 mm) and torque to 24.5-29.5 Nm (18-22 lb-ft).

NOTICE: Do not over-torque the Oil Fill Plug or transmission damage may occur.

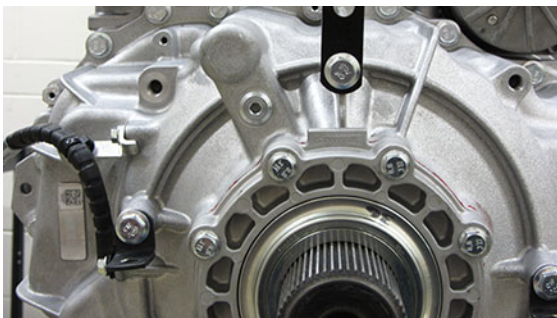

Clutch and Rail Calibration

To ensure proper operation, the TCM, clutch, MTM and transmission require a Clutch and Rail Calibration. Calibrations are automatically initiated when:

- LCA is in the reset position
- Transmission in “N” (Neutral)
- Key on engine running
- Vehicle air system pressure at operating range

NOTICE: Do not use service tool to initiate calibrations. Allow calibrations to automatically initiate.

Note: Vehicle display may indicate a flashing “CC” and “F” in gear display.

1. Set vehicle parking brake and chock wheels.
2. Ensure the driveline is connected between the transmission and axle.

Note: Clutch and Rail Calibrations cannot complete if the transmission output shaft is allowed to rotate.
3. Key on with engine running.
4. Allow vehicle air pressure to build to governor cut-off.

Note: Clutch and Rail Calibrations automatically initiate when vehicle air pressure reaches approximately 100 psi.
5. Ensure “N” (Neutral) is selected and engine is running. Wait approximately 2 minutes for calibrations to complete.

NOTICE: If process is interrupted, key off, wait 1 minute and go to **Step 2**.

- If vehicle display indicates a solid “N: (Neutral) in gear display, calibrations are complete. Key off, go to **Step 6**.
 - If vehicle display continues to indicate a flashing “CC” and/or “F” in gear display or service transmission message, go to **Step 5**.
6. Key off and wait 1 minute.

7. Key on with engine off.
8. Connect ServiceRanger.
9. Go to “Fault Codes”.
 - If an Active transmission fault code is set, go to Endurant HD Troubleshooting Guide TRTS0950 **Diagnostic Procedure**.
 - If no Active transmission fault codes are set, select “Clear Eaton Faults” and follow on-screen prompts. Go to **Step 9**.
10. Disconnect ServiceRanger.
11. Key off.
12. Determine next step.
 - If transmission oil was **not** drained, process complete.
 - If transmission oil was drained, go to **Step 12**.
13. Inspect transmission for a PTO.
 - If not PTO-equipped, process complete.
 - If PTO-equipped, start the engine and run for 1 to 2 minutes to fill the PTO with oil, key off and repeat the Fill Oil Procedure.



CAUTION: Failure to repeat the Fill Oil service procedure to verify proper transmission oil level when equipped with a PTO may result in low transmission oil and component damage.

Fluid Pressure Sensor (FPS)

Special Instructions

The Fluid Pressure Sensor can be removed and installed with the transmission in-vehicle.

Special Tools

None

Component Identification

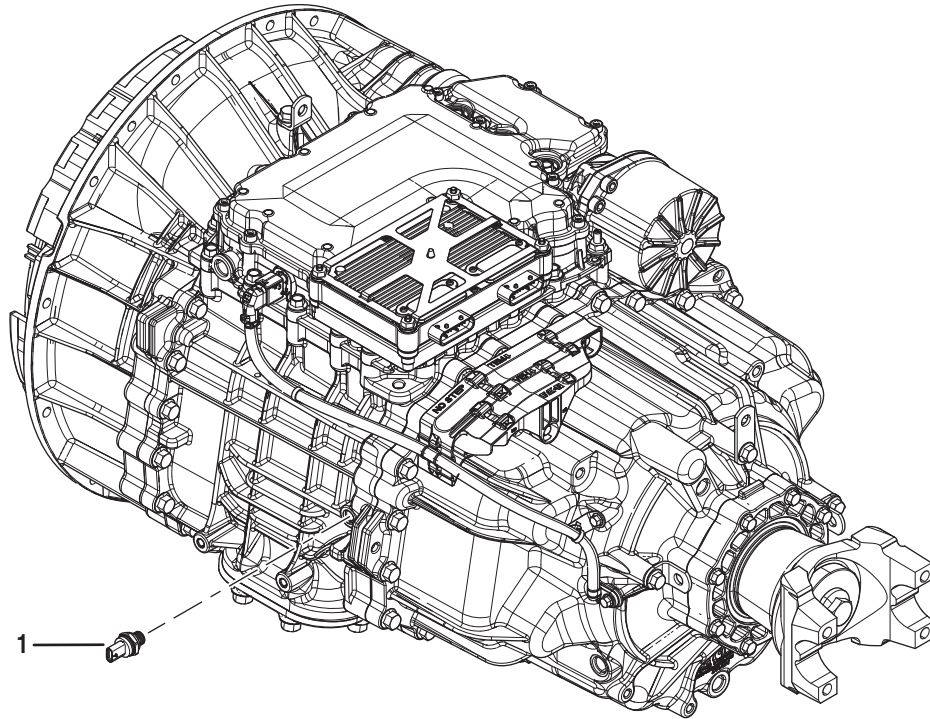

1. Fluid Pressure Sensor (x1)

Create a Service Activity Report

Note: If not already created and sent.

1. Key on with engine off.
2. Connect ServiceRanger and create a Service Activity Report.
3. Select "Send to Eaton" (internet connection required)
4. Disconnect ServiceRanger.
5. Key off.

Remove the Fluid Pressure Sensor (FPS)

1. Unlatch and disconnect the OEM 3-Way Transmission Fluid Pressure Sensor (FPS) Connector.

Note: There are two possible Main Housing FPS port designs. FPS removal and installation have the same procedure for both designs.

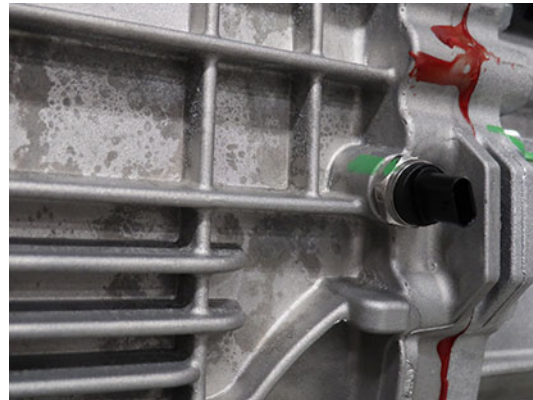
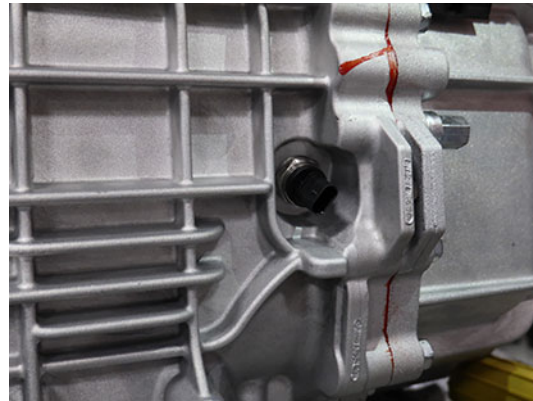

2. Remove the Transmission FPS (24 mm) threaded into the main housing.



Install the Fluid Pressure Sensor (FPS)

1. Inspect the Fluid Pressure Sensor (FPS) and O-ring for damage. If damaged, replace the FPS; O-ring is serviced with sensor.



2. Install the Transmission FPS (24 mm) into the Main Housing and torque to 19-23 Nm (14-17 lb-ft).

Note: There are two possible Main Housing FPS port designs. FPS removal and installation have the same procedure for both designs.



3. Connect and latch the OEM 3-Way Transmission FPS Connector.

Output Speed Sensor

Special Instructions

None

Special Tools

None

Component Identification

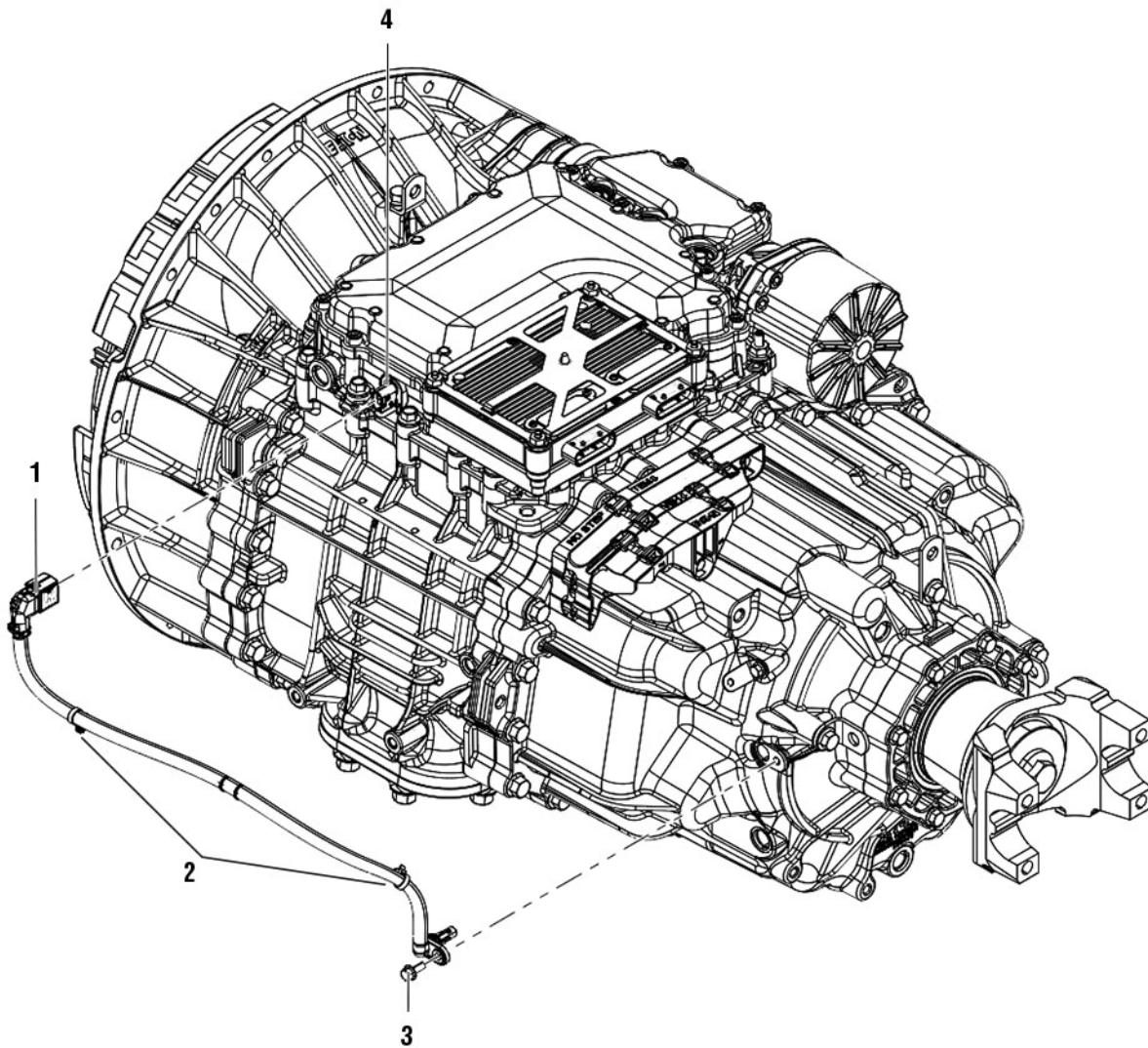

1. Output Speed Sensor Harness
2. Harness Retainers (x2)
3. Cap Screw - 10 mm
4. Output Speed Sensor Connector

Create a Service Activity Report

Note: If not already created and sent.

1. Key on with engine off.
2. Connect ServiceRanger and create a Service Activity Report.
3. Select "Send to Eaton" (internet connection required)
4. Disconnect ServiceRanger.
5. Key off.

Disconnect the Output Speed Sensor

1. Lift the latch on the Output Speed Sensor Harness at the Connector on the Mechatronic Transmission Module (MTM).



2. Remove the Output Speed Sensor Harness from the Connector on the MTM.

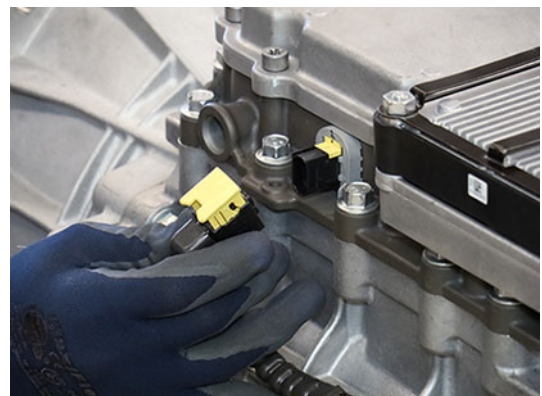

Remove the Output Speed Sensor

1. Remove the Output Speed Sensor Harness tie strap at the Harness Bracket.



2. Remove the 2 harness press-in retainers from the Main Housing and bracket on Rear Housing.



3. Remove the Output Speed Sensor 10 mm cap screw.



- Remove the Output Speed Sensor from the Rear Housing.

Note: The sensor may need to be twisted and pulled from the bore.



Install the Output Speed Sensor

- Clean the sensor bore.

NOTICE: Do not use abrasive scrapers or powered tools to clean sealing surface.

- Apply a light coat of transmission oil to the sensor O-ring.

- Install the Output Speed Sensor into the bore.

Note: The Sensor may need to be twisted and pushed into the bore.



- Install the Output Speed Sensor 10 mm cap screw and torque to 8.8-10.4 Nm (6-8 lb-ft).



5. Press the 2 harness press-in retainers into the Main Housing and the bracket on the rear housing.



6. Secure the Output Speed Sensor Harness to the Harness Bracket with a tie strap.



CAUTION: Failure to tie strap the Output Speed Sensor Harness to the Harness Bracket may result in harness damage.



Connect the Output Speed Sensor

1. Connect the Output Speed Sensor Harness to the Connector on the Mechatronic Transmission Module (MTM) and close the latch.



Mechatronic Transmission Module (MTM)

Special Instructions

When replacing original equipment MTM with a new/replacement MTM, locate new/replacement MTM part information tag and record Part Number and Serial Number for future reference in this procedure.

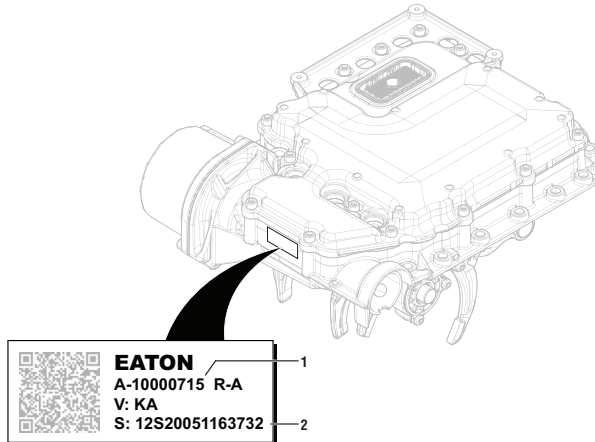

1. Part Number
2. Serial Number

NOTICE: Ensure vehicle air system provides proper transmission air supply and air quality, refer to “Vehicle Maintenance Recommendations” on page 459. Failure to provide proper transmission air supply and air quality results in degraded transmission performance and transmission component damage.

Note: For EHD-xxF112C-N transmission models with TCM software 5516034, contact Eaton Cummins Automated Transmission Technologies at +1-800-826-4357 for further diagnostic instructions.

Special Tools

- Mechanical Diagnostic Kit (RR2011TR)
- Gasket Sealant (Loctite 5188)
- Plastic Scraper
- Non-Chlorinated Brake Cleaner (Gasket Remover)



DANGER: Do not handle non-chlorinated brake cleaner until all manufacturer precautions have been read and understood. Failure to follow precautions will result in serious personal injury or death.



CAUTION: Avoid contact between non-chlorinated brake cleaner and the transmission plastic components, electrical wiring and connectors. Failure to avoid contact will result in transmission component damage.

Component Identification

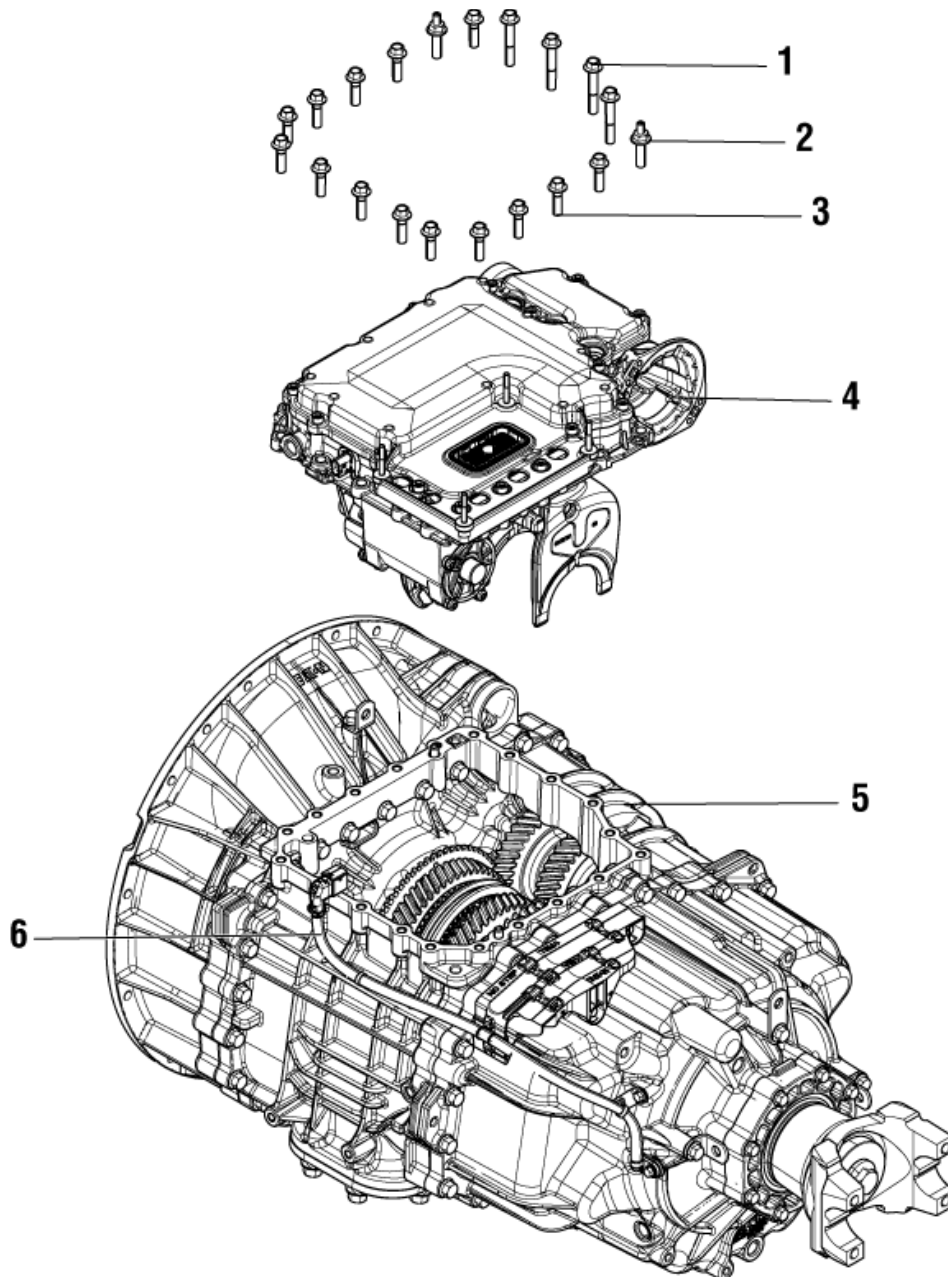

- 1. *MTM Cap Screws, Long (x4) - 13 mm*
- 2. *MTM Cap Screws, Special (x2) - 15 mm*
- 3. *MTM Cap Screws (x14) - 13 mm*

- 4. *Mechatronic Transmission Module (MTM)*
- 5. *Main Housing*
- 6. *Output Speed Sensor*

Create a Service Activity Report

Note: If not already created and sent.

1. Key on with engine off.
2. Connect ServiceRanger and create a Service Activity Report.
3. Select "Send to Eaton" (internet connection required)
4. Disconnect ServiceRanger.
5. Key off.

Drain Oil

1. Locate the Oil Drain Plug on the back of the rear housing.
2. Place a suitable container under the Oil Drain Plug.

Note: If reusing oil, use a clean container free of contamination and debris.

3. Remove the Oil Drain Plug with a 6 mm hex key and drain the oil.



4. If PTO-equipped, remove PTO and drain the oil.
5. Inspect Oil Drain Plug and O-ring for damage. If damaged, replace the Oil Drain Plug; O-ring is serviced with plug.

6. Install the Oil Drain Plug (6 mm) and torque to 24.5-29.5 Nm (18-22 lb-ft).

NOTICE: Do not over-torque drain plug or transmission damage may occur.

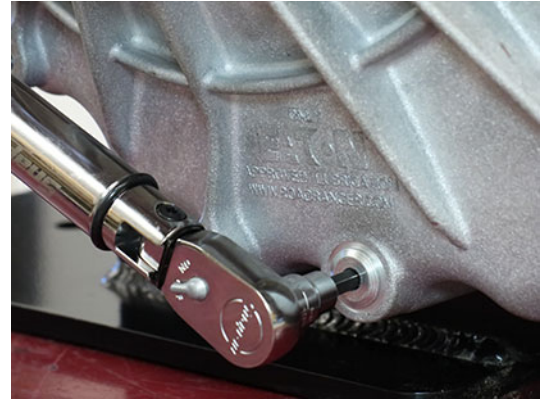

Manually Vent Linear Clutch Actuator (LCA)

1. Key off.
2. Set vehicle parking brake and chock wheels.

! **WARNING:** Apply vehicle parking brake and follow vehicle manufacture parking instructions. Failure to follow these instructions could cause unintended vehicle movement and may result in major vehicle component damage, severe injury or death.

3. Loosen the 4 Linear Clutch Actuator (LCA) cap screws 1-2 turns each with a T45 Torx.

Note: Residual air pressure in the LCA cylinder exhausts between the LCA and Mechatronic Transmission Module (MTM) housing when the cap screws are loosened.

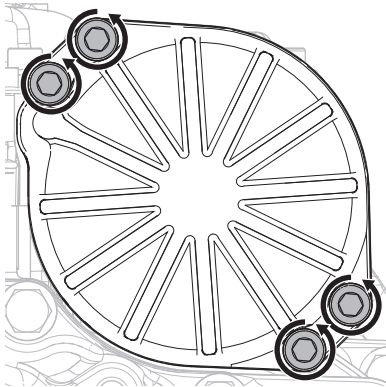

4. Tighten the 4 LCA to MTM T45 cap screws and torque to 23-27 Nm (17-21 lb-ft).

Remove the Transmission

1. Disconnect negative battery cable.
2. Refer to OEM guidelines for transmission removal.

Remove the Release Bearing and Clutch Release Yoke

1. Remove the Release Bearing by sliding the bearing off the input shaft.



2. Pull to free the lower Clutch Release Yoke socket from the lower pivot on the clutch housing.



3. Pull to free the upper Clutch Release Yoke socket from the Linear Clutch Actuator (LCA) rod end.



4. Inspect the plastic socket inserts in the Clutch Release Yoke to verify none of the fingers are missing or damaged.

Note: If the plastic insert is damaged, replace the Clutch Release Yoke assembly.



Remove the Transmission Control Module (TCM)

1. Unscrew the 4 TCM Cover nuts and remove TCM Cover.

Note: TCM Cover nuts are 10 or 13 mm.



2. Unscrew the TCM 7 mm Jackscrew. Lift and remove the TCM from the MTM.

NOTICE: Do not allow contamination into the connectors on the TCM or MTM.



3. Inspect the TCM Seal for damage.

NOTICE: Replace the TCM Seal if damaged.

Note: If replacing the TCM, the REMAN TCM includes a new seal.



Remove the Mechatronic Transmission Module (MTM)

1. Lift the latch on the Output Speed Sensor Harness at the Connector on the Mechatronic Transmission Module (MTM).



2. Remove the Output Speed Sensor Harness from the Connector on the MTM.



3. Remove the 20 MTM cap screws.

Note: 13 mm (x18), 15 mm (x2).

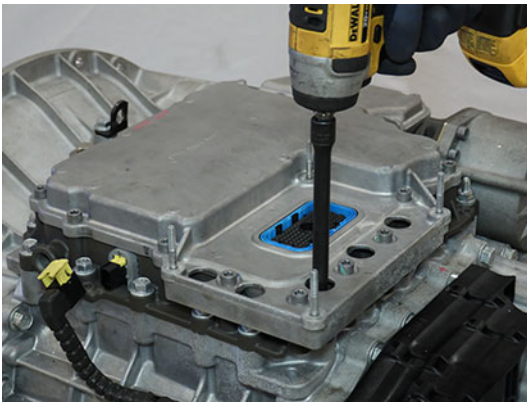

4. Separate the MTM from the Main Housing at the 2 pry points.

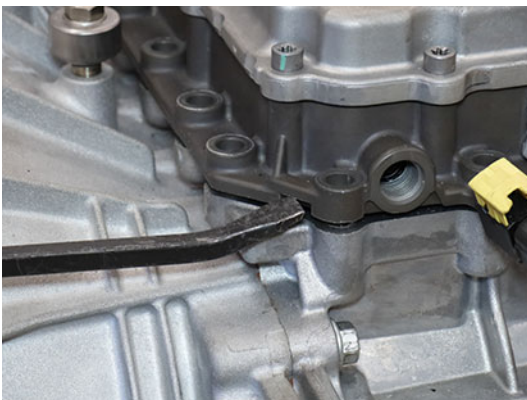
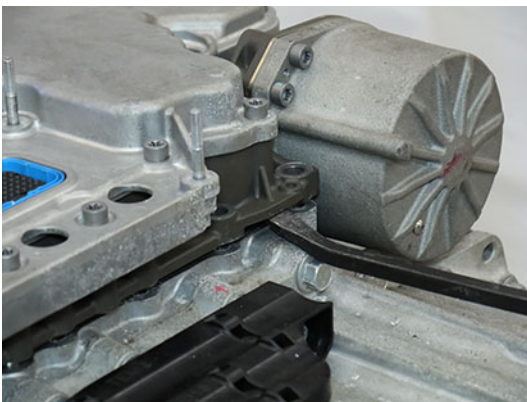

5. Remove the MTM from the transmission housing.

⚠ CAUTION: MTM weighs approximately 40 lbs. Keep fingers clear of pinch point between MTM and other surfaces. Dropping MTM could result in component damage and/or personal injury.



Install the Mechatronic Transmission Module (MTM)

Note: If replacing original equipment MTM with new/replacement MTM locate new/replacement MTM part information tag and record Part Number and Serial Number. Refer to Component Identification section. Part Number and Serial Number are required to properly configure TCM after MTM installation.

1. Place the transmission in a horizontal position.

NOTICE: The transmission must be in a horizontal position prior to the MTM Installation procedure. Failure to do so causes the sliding clutches to move out of neutral and not align to the shift yokes. If the shift yokes are not aligned to the sliding clutches, position sensor fault codes set Active and the transmission will not shift out of neutral.

2. Clean the sealing surfaces on the transmission and Mechatronic Transmission Module (MTM) with gasket remover and a plastic scraper. Let air dry then wipe with a clean dry cloth.

NOTICE: Do not use abrasive scrapers or powered tools to clean sealing surfaces or sealing surfaces may be damaged and leak.

3. Inspect threaded bolt holes for debris and clean if necessary.

NOTICE: Ensure there is nothing in the threaded bolt holes or the transmission may be damaged when cap screws are tightened.

4. Install the Rail B Engagement Tool (RR1088TR) to the Main Housing

5. Install and hand tighten 2 MTM cap screws leaving a 3.175 mm (1/8 inch) gap between the cap screws and tool base.

NOTICE: Hand tighten cap screws only, do not over torque. Rail B Engagement Tool must remain loose to ensure complete movement of the synchronizer sliding sleeve. Over torqued cap screws result in binding between tool and sliding sleeve.



6. Shift the Rail B Synchronizer to neutral.

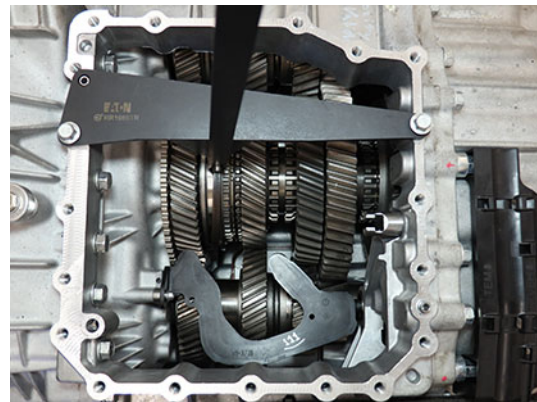

7. Remove the Rail B Engagement Tool.

8. Move Rail C and Rail D sliding clutches to neutral.

NOTICE: The transmission must be in a horizontal position prior to the MTM Installation procedure. Failure to do so causes the sliding clutches to move out of neutral and not align to the shift yokes. If the shift yokes are not aligned to the sliding clutches, position sensor fault codes set Active and the transmission will not shift out of neutral.



9. Install the Confirm-Neutral Gauge (RR1086TR-2) into the slots of the synchronizer and sliding clutches.

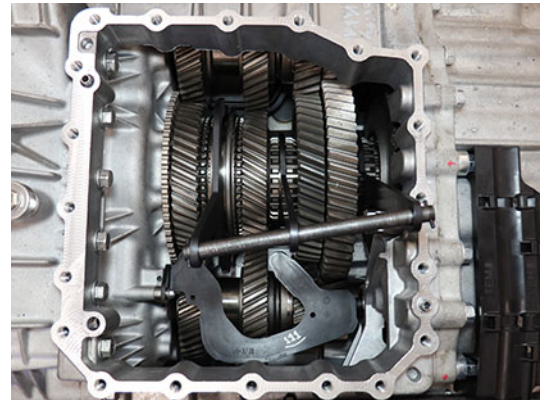

10. Install the MTM Alignment Tool (RR1086TR-1) onto the main housing.

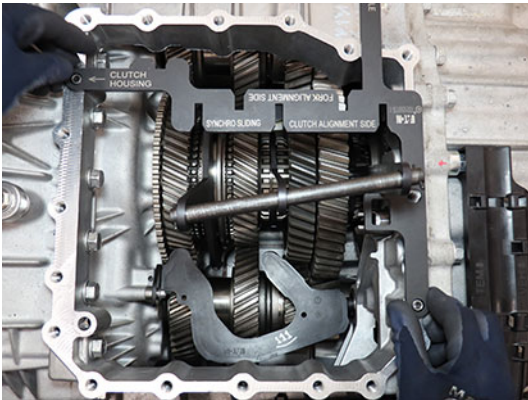

11. Verify synchronizer and sliding clutches are in neutral by sliding Confirm-Neutral Gauge into the slots of MTM Alignment Tool.

Note: If the gauge does not slide into the alignment tool slots, neutral is not achieved. Go to Step 4.

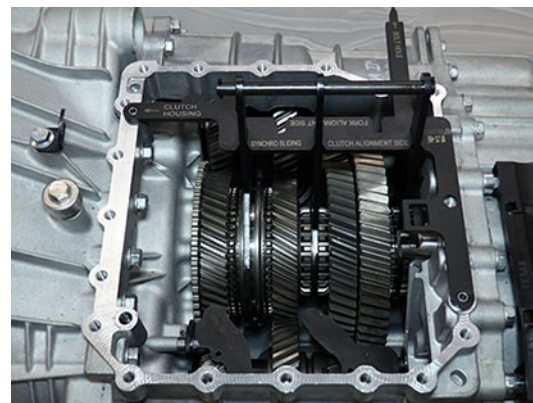

12. Using the Rail E Lever, move Rail E to neutral.

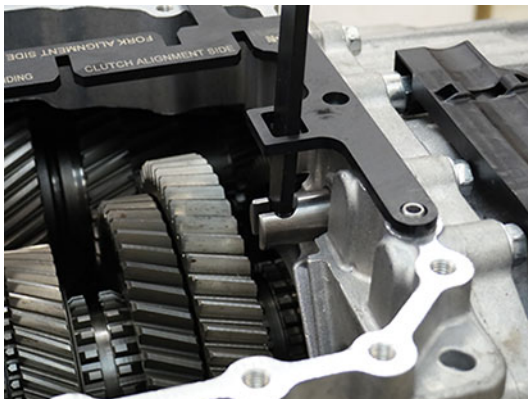
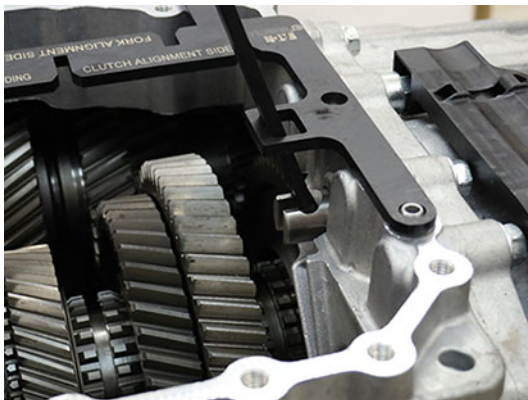
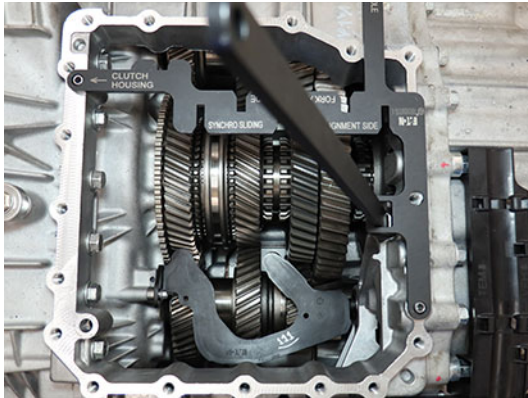

13. Verify Rail E is in neutral using the Gear Side Actuator end of the Confirm-Neutral Gauge (RR1088TR-2) at Shift Rail E. Rail E is in neutral when end of gauge rests against housing with rail against notch-end of gauge.

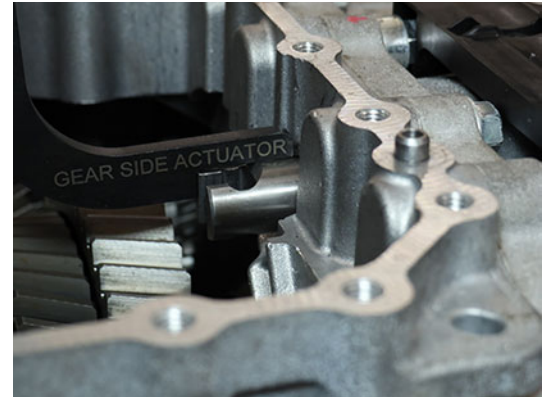

14. Move Shift Rail B in the MTM to neutral. Rail B is in neutral when the ball detent is in the notch of the Rail B yoke assembly.

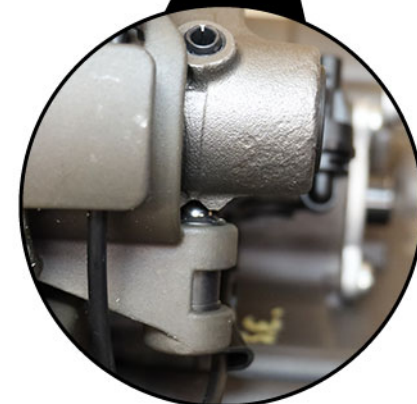
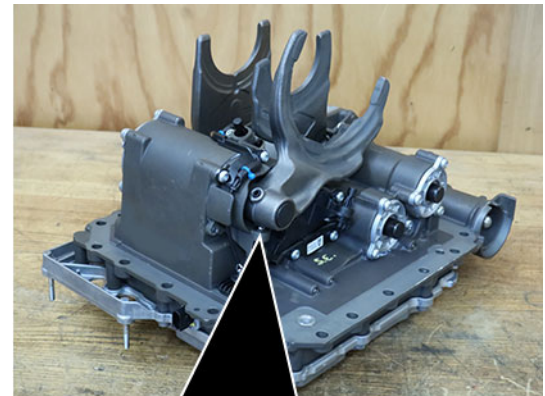

15. Move Shift Rails C and D in the MTM to neutral. Rails C and D are in neutral when the shift inter-lock is aligned with the notches of the rail yoke assemblies.

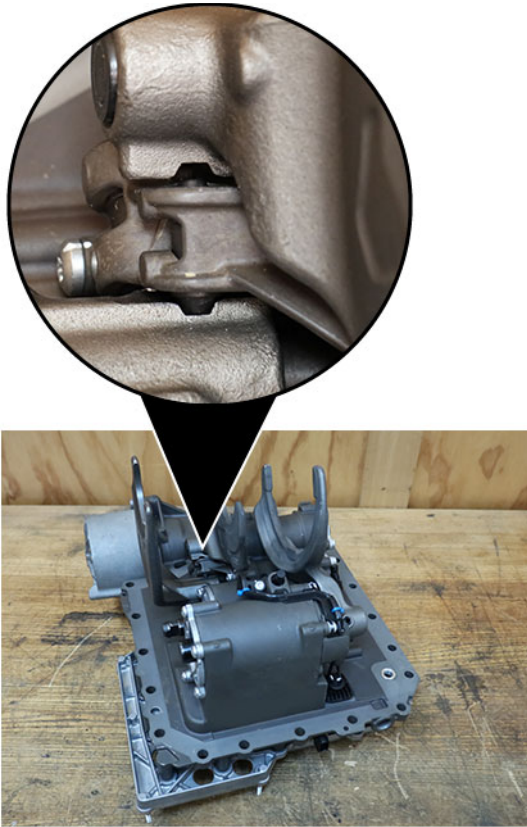

16. Verify MTM is in neutral. Install the MTM Alignment Tool (RR1086TR-1) into the bolt hole and onto Rail B, C, and D Shift Yokes.

Note: If the MTM Alignment Tool slots do not align with the 3 shift yokes, neutral has not been achieved. Go to Step 13.



17. Inspect and confirm orientation of notch on Rail E as shown in image below (notch facing up when MTM is installed on transmission). If not in orientation shown, rotate Rail E as needed.

NOTICE: If notch on Rail E is facing down when MTM is installed on transmission, Fault Code 320 (SPN 5942) sets Active and transmission does not shift out of neutral.

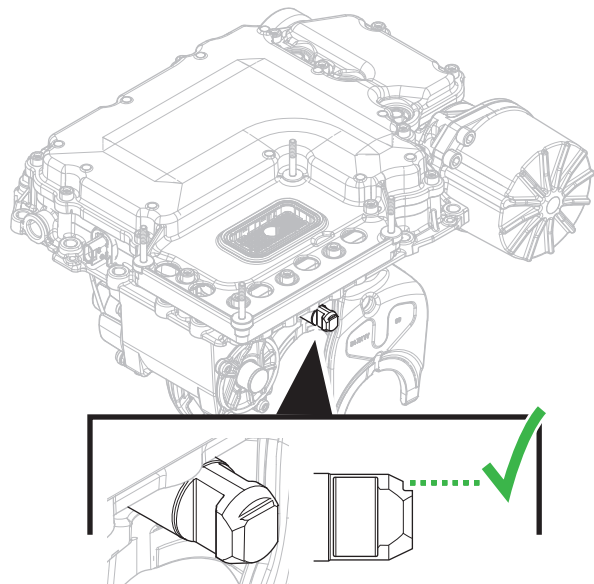

18. Verify Rail E is in neutral using the Fork Side Actuator end of the Confirm-Neutral Gauge (RR1088TR-2) at Shift Rail E. Rail E is in neutral when end of gauge rests against cover with rail against notch-end of gauge.

Note: If Rail E is not in neutral, slide rail in or out until neutral is achieved.



19. Slide O-ring over the MTM front alignment pin on the main housing until fully seated in the groove.

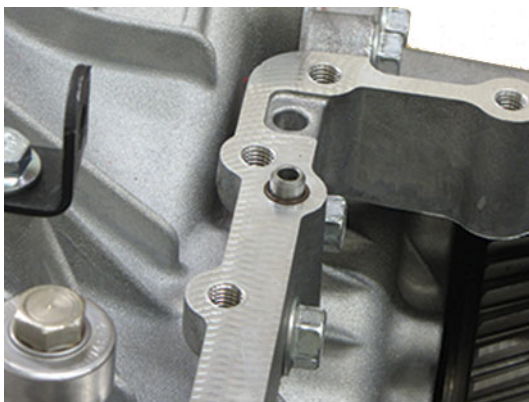

20. Clean the sealing surfaces on the transmission and Mechatronic Transmission Module (MTM) with gasket remover and a plastic scraper. Let air dry then wipe with a clean dry cloth.

NOTICE: Do not use abrasive scrapers or powered tools to clean sealing surfaces or sealing surfaces may be damaged and leak.

21. Apply gasket sealant with a bead width of 1.4-2.4mm (0.055-0.094 inch) to the transmission housing sealing surface following the pattern below.

NOTICE: Ensure there is nothing in the threaded bolt holes or the transmission may be damaged when cap screws are tightened.

Note: Parts must be assembled within 10 minutes of applying Gasket Sealant.

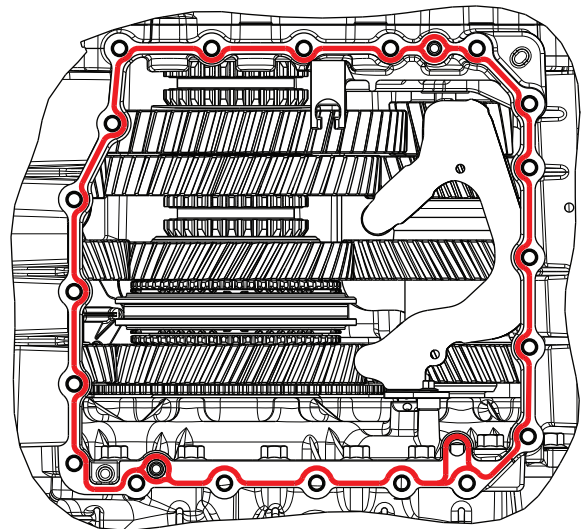

22. Install MTM onto the transmission housing. Align Rail E in the MTM with the Rail E Shift Rail in the Main Housing.

CAUTION: MTM weighs approximately 40 lbs. Keep fingers clear of pinch point between MTM and other surfaces. Dropping MTM could result in component damage and/or personal injury.

NOTICE: If the MTM is installed on the transmission and Rail E in the MTM is not aligned with Rail E in the Main Housing, Fault Code 320 (SPN 5942) sets Active and the transmission will not shift out of neutral.

23. Install 20 MTM cap screws and torque to 44.5-51.5 Nm (33-38 lb-ft) in a criss-cross pattern.

Note: 13 mm (x18), 15 mm (x2) cap screws.



Install the Transmission Control Module (TCM)

NOTICE: Do not allow contamination into the connectors on the TCM or MTM.

Note: TCM can be installed with transmission in-vehicle.

1. Install the TCM Seal on the 74-Way Harness Connector.



2. Align the TCM to the 74-Way Harness Connector and TCM studs, then install the TCM.



- Torque the TCM 7 mm Jackscrew to 3.0-4.0 Nm (26.6-35.4 lb-in).

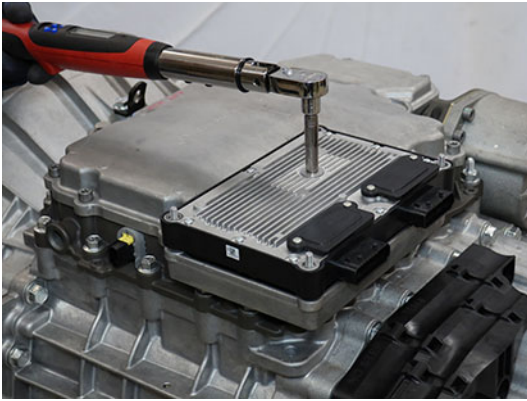

- Install the TCM Cover over the 4 TCM studs and torque the 4 TCM Cover Nuts to 8.8-10.4 Nm (78-92 lb-in) in a criss-cross pattern.

Note: TCM Cover nuts are 10 or 13 mm.

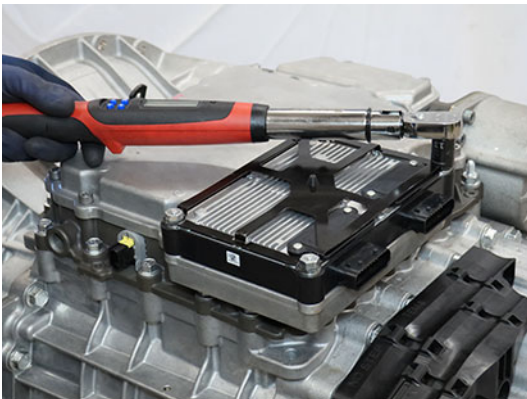

Remove the Linear Clutch Actuator (LCA)

- Loosen the 4 LCA cap screws 1-2 turns each with a T45 Torx.

NOTICE: Ensure key is off, 20-Way TCM Vehicle and Body Harness Connectors are disconnected, and 5 minutes has passed prior to LCA removal.

Note: Residual air pressure in the LCA cylinder exhausts between the LCA and MTM housing when the cap screws are loosened.



- Remove the 4 LCA cap screws
- Remove the LCA from the MTM.

Note: LCA piston rod end is seated in the release yoke socket; pull to release rod end from socket.



- Inspect the plastic socket insert in the release yoke through the LCA opening using a flashlight to verify none of the fingers are missing or damaged.

Note: If the plastic insert is damaged, replace the release yoke assembly.

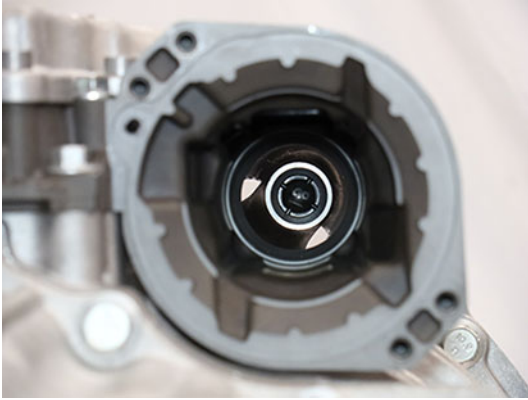

Reset and Install Linear Clutch Actuator (LCA)

- Inspect LCA to determine next steps, reference images below:
 - If LCA is locked in the reset position, go to Install Linear Clutch Actuator (LCA).
 - If LCA is not locked in the reset position, go to Step 2.

Locked in Reset Position

Not Locked in Reset Position

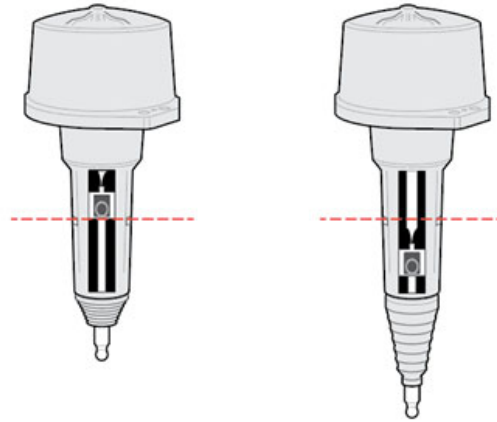

- Place LCA push rod on a clean, flat surface. Tightly grasp LCA housing with both hands and push down on push rod to lock LCA into the reset position.



CAUTION: A large amount of force is required to lock the LCA into the reset position. Failure to tightly grasp the LCA housing with both hands while pushing down on push rod may cause unintended movement resulting in personal injury and/or component damage.

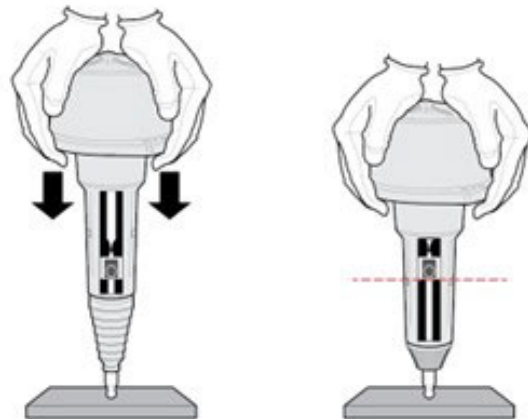

3. Inspect LCA to determine next steps, reference images below:

- If LCA remains locked in the reset position, go to Step 4.
- If LCA does not remain locked in the reset position, go to Step 2, repeat reset procedure.

Note: If LCA cannot be locked into the reset position, replace LCA.



CAUTION: Do not drop LCA. Dropping LCA may cause the LCA to unlock resulting in personal injury and/or component damage.

Locked in Reset Position

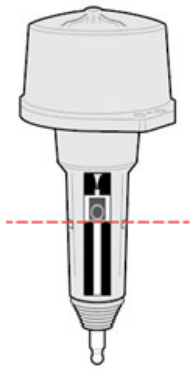

Not Locked in Reset Position

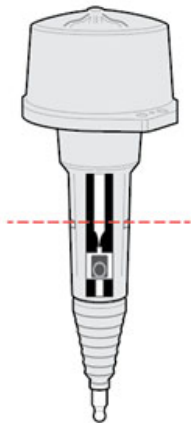

4. Clean all sealing surfaces on the MTM and LCA with a lint free cloth.

NOTICE: Do not use abrasive scrapers or powered tools to clean sealing surfaces or sealing surfaces may be damaged and leak.

5. Insert the LCA into the MTM.



6. Install 4 LCA T45 cap screws and torque to 23-28 Nm (17-21 lb-ft) in a criss-cross pattern.

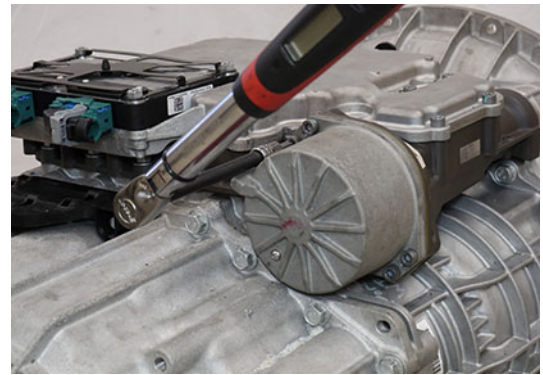

Install the Release Bearing and Clutch Release Yoke

1. Install the upper Release Yoke socket over the rod end of the Linear Clutch Actuator (LCA) and press until attached.



2. Install the lower Release Yoke socket over the lower pivot on the clutch housing and press until attached.



3. Slide the Release Bearing over the input shaft and into the Release Yoke.



Install the Transmission

1. Refer to OEM guidelines for transmission installation.
2. Connect negative battery cable.

Fill Oil

Note: Perform the transmission fill procedure with transmission installed in vehicle to ensure proper transmission angle.

1. Remove the Oil Fill Plug with a 6 mm hex key.

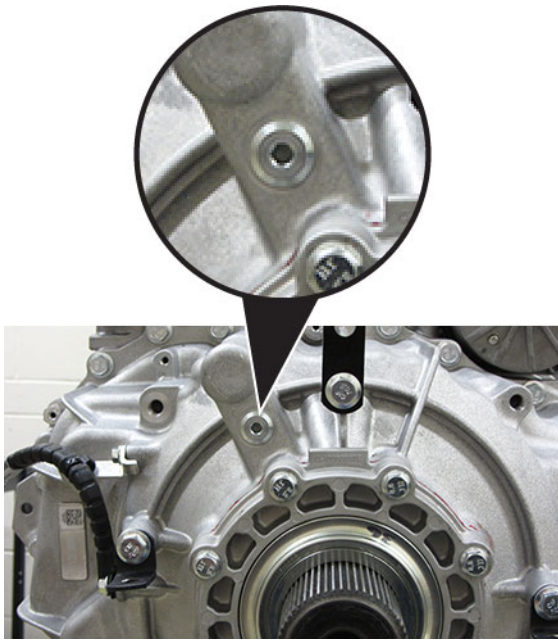

2. Place a suitable container under the Oil Check Plug and remove the Oil Check Plug with a 6 mm hex key.



3. Fill the transmission with PS-386 lube until a small amount of oil runs out of the Oil Check Plug hole.

Note: Fill capacity is approximately 7.5-8.5 liters (16-18 pints) depending on the transmission angle.

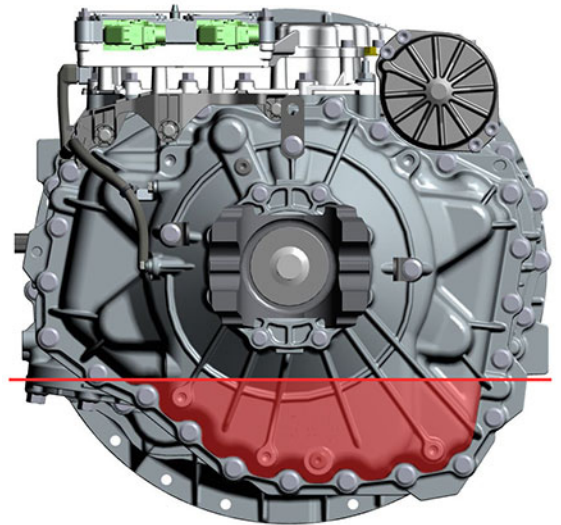
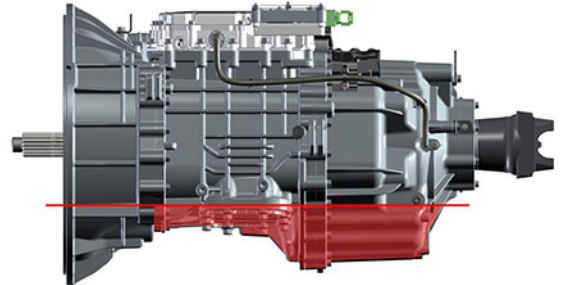

4. Inspect Oil Check Plug and O-ring for damage. If damaged, replace the Oil Check Plug; O-ring is serviced with plug.

5. Install the Oil Check Plug (6 mm) and torque to 24.5-29.5 Nm (18-22 lb-ft).

NOTICE: Do not over-torque the Oil Fill Plug or transmission damage may occur.



6. Inspect Oil Fill Plug and O-ring for damage. If damaged, replace the Oil Fill Plug; O-ring is serviced with plug.
7. Install the Oil Fill Plug (6 mm) and torque to 24.5-29.5 Nm (18-22 lb-ft).

NOTICE: Do not over-torque the Oil Fill Plug or transmission damage may occur.

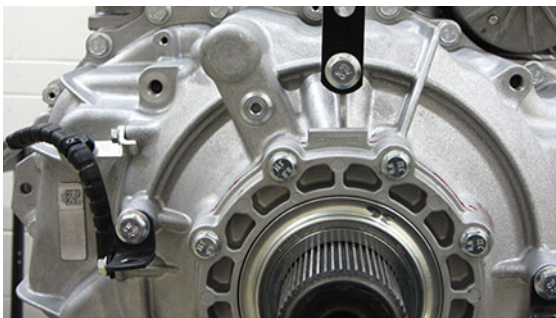

Determine installation of New/Replacement or Original Equipment MTM

1. Determine next step:
 - If installing a new/replacement MTM, go to **Configure MTM Type**.
 - If re-installing original equipment MTM, go to **Clutch and Rail Calibration**.

Configure MTM Type

Overview

To ensure proper transmission operation after new/replacement MTM installation, TCM and MTM need to be properly configured. To complete Configure MTM Type procedure, MTM part number and serial number, and TCM software part number are required.

1. Key off.
2. Set vehicle parking brake and chock wheels.
3. Record MTM Part Number and MTM Serial Number installed on transmission.

| | |
|--|----------------------|
|  EATON A-10000715 R-A V: KA S: 12S20051163732 | 1 |
| | 2 |
| 1. MTM Part Number | 2. MTM Serial Number |
| | |

4. Key on with engine off.
5. Connect ServiceRanger.
6. Go To “Programming”.
7. Record TCM Software Part Number listed under “Software Information”.

| |
|---------------------|
| TCM Software |
| |

8. Compare TCM Software Part Number recorded in Step 7 to table:

NOTICE: For EHD-xxF112C-N transmission models, TCM Software 5516042 or greater may not be available. If not, contact Eaton Cummins Automated Transmission Technologies at +1-800-826-4357 for further diagnostic instructions.

| <i>If TCM Software is less than 5516042</i> | <i>If TCM Software is 5516042 or Greater</i> |
|--|---|
| <ol style="list-style-type: none"> A. From available updates, select latest available software. B. Select confirm and follow on-screen prompts. C. Go to Step 9. | <p>Go to Step 9.</p> <p>Note: TCM software is at appropriate level.</p> |

13. Select “Advanced”.
14. From “MTM Type” New Value drop down select MTM Type recorded in Step 9.
15. Select “Apply” and follow on-screen prompts.
16. Key on with engine off.
17. Connect ServiceRanger.
18. Go To “Configuration”.
19. Select “Identification”.
20. In “Current MTM Serial Number” New Value field enter MTM Serial Number recorded in Step 3.
21. Select “Apply” and follow on-screen prompts.

9. Compare MTM Part Number recorded in Step 3 with MTM Part Number in table and record MTM Type.

| <i>MTM Part Number</i> | <i>MTM Type</i> |
|------------------------|-----------------|
| A-10004231 | PS-496 |
| A-10004356 | |
| A-10004383 | |
| A-10000715 | PS-393 |
| A-10002594 | |
| A-10004202 | |

10. Key on with engine off.
11. Connect ServiceRanger.
12. Go To “Configuration”.

Clutch and Rail Calibration

To ensure proper operation, the TCM, clutch, MTM and transmission require a Clutch and Rail Calibration. Calibrations are automatically initiated when:

- LCA is in the reset position
- Transmission in “N” (Neutral)
- Key on engine running
- Vehicle air system pressure at operating range

NOTICE: Do not use service tool to initiate calibrations. Allow calibrations to automatically initiate.

Note: Vehicle display may indicate a flashing “CC” and “F” in gear display.

1. Set vehicle parking brake and chock wheels.
2. Ensure the driveline is connected between the transmission and axle.

Note: Clutch and Rail Calibrations cannot complete if the transmission output shaft is allowed to rotate.
3. Key on with engine running.
4. Allow vehicle air pressure to build to governor cut-off.

Note: Clutch and Rail Calibrations automatically initiate when vehicle air pressure reaches approximately 100 psi.
5. Ensure “N” (Neutral) is selected and engine is running. Wait approximately 2 minutes for calibrations to complete.

NOTICE: If process is interrupted, key off, wait 1 minute and go to Step 2.

 - If vehicle display indicates a solid “N: (Neutral) in gear display, calibrations are complete. Key off, go to Step 6.
 - If vehicle display continues to indicate a flashing “CC” and/or “F” in gear display or service transmission message, go to Step 5.
6. Key off and wait 1 minute.
7. Key on with engine off.
8. Connect ServiceRanger.



9. Go to “Fault Codes”.
 - If an Active transmission fault code is set, go to Endurant HD Troubleshooting Guide TRTS0950 **Diagnostic Procedure**.
 - If no Active transmission fault codes are set, select “Clear Eaton Faults” and follow on-screen prompts. Go to Step 9.
10. Disconnect ServiceRanger.
11. Key off.
12. Inspect transmission for a PTO.
 - If not PTO-equipped, process complete.
 - If PTO-equipped, start the engine and run for 1 to 2 minutes to fill the PTO with oil, key off and repeat the Fill Oil Procedure.

CAUTION: Failure to repeat the Fill Oil service procedure to verify proper transmission oil level when equipped with a PTO may result in low transmission oil and component damage.

MTM Rail B, C and D Cylinder

Special Instructions

- Perform this entire procedure only if guided here by MTM Rail B, C and D Cylinder Inspection Procedure.
- Reference the relevant warranty information provided in service bulletin **TAIB-0994**.

Special Tools

- T30 Torx Bit
- Torque Wrench - Nm (in lbs.)
- PS-386 HD Synthetic Transmission Lubricant
- Parts Cleaner (Loctite SF 7063 or equivalent)
- **K-4637** MTM O-ring Kit (Rail B, C, D Cylinders)



CAUTION: Only use items outlined above. Failure to follow these instructions could result in MTM damage.

Component Identification

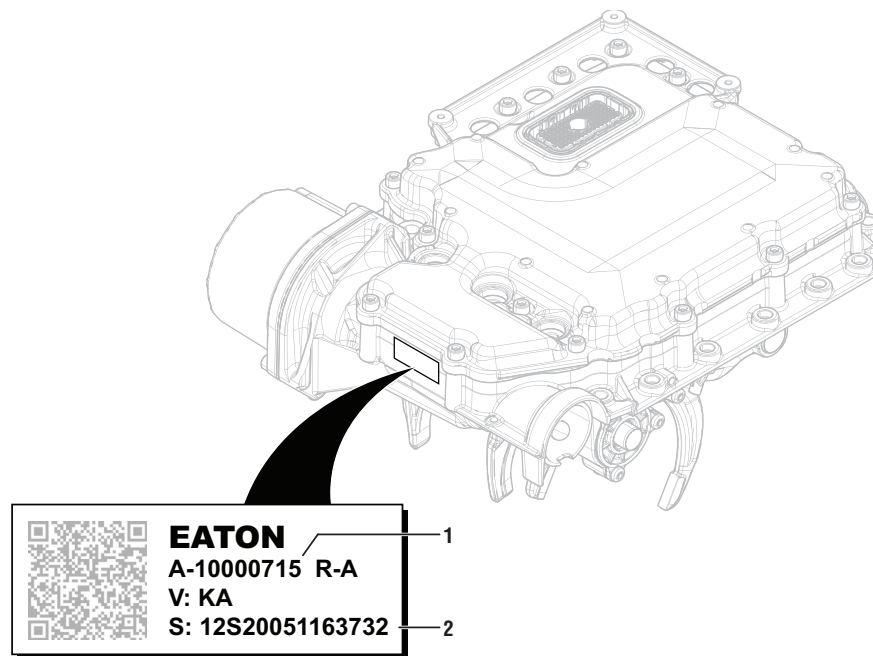

1. Part Number
2. Serial Number

Disassemble Rail B

1. Place MTM on a clean surface.

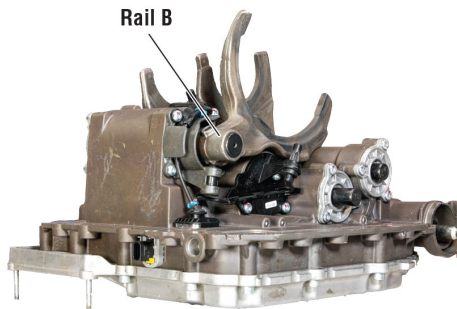

2. Remove 4 Rail B Shift Yoke Cylinder Cover T30 cap screws (1, 2, 3, 4 - M6x65).

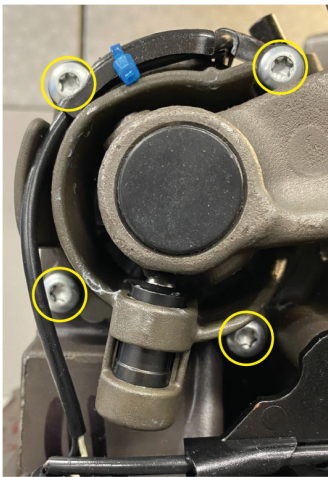

3. Remove 1 Countershaft Speed Sensor T30 cap screw (5 - M6x65).

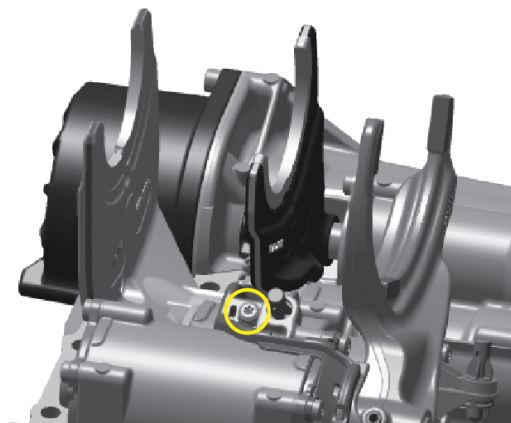

4. Rotate Countershaft Speed Sensor clockwise 90 degrees.

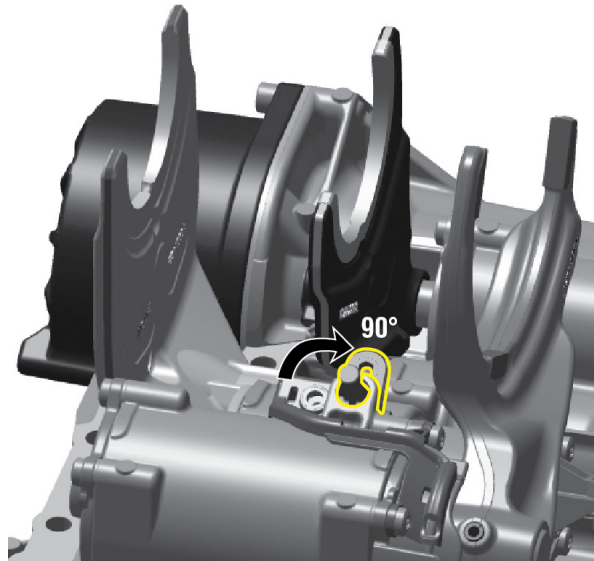

5. Remove sensor from housing.

Note: Ensure sensor and harness are free from housing to avoid damage during shift yoke removal.



- Firmly grasp and remove Rail B Shift Yoke assembly from cylinder.

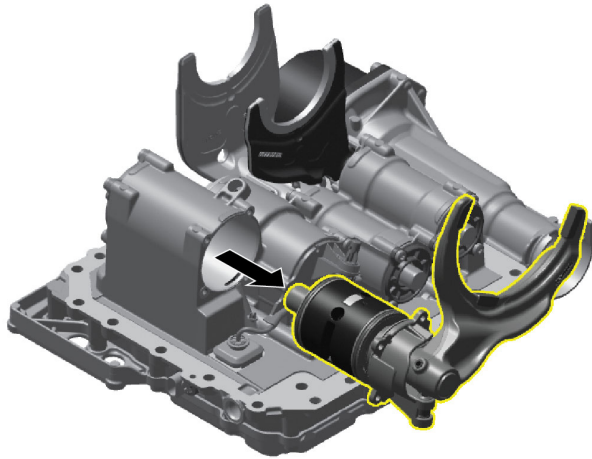

- Place Rail B Shift Yoke assembly on a clean surface.

Assemble Rail B

- Remove Rail B Shift Yoke cover O-ring from cover groove.



- Slide O-ring over piston assembly.

Note: Do not damage or remove piston O-ring.



- Lubricate new Rail B Shift Yoke cover O-ring 64mm (2.5 inches) with PS-386 HD Synthetic Transmission Lubricant.

4. Install new Rail B Shift Yoke cover O-ring, slide over piston assembly and into cover groove.

Note: Ensure O-ring is fully seated in groove.



5. Inspect Rail B cylinder for contamination. Remove any contamination and excessive oil with a lint-free cloth.

Note: Do not remove residual cylinder lubricant. If necessary, lightly lubricate cylinder with PS-386 HD Synthetic Transmission Lubricant.

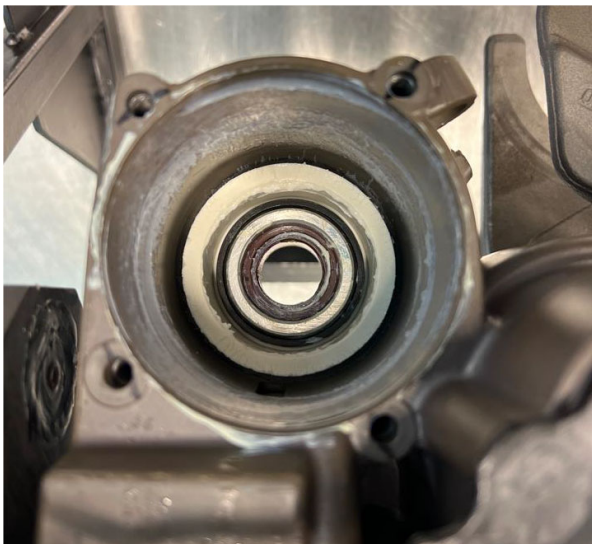

6. Clean Rail B cylinder cover threaded holes with parts cleaner.

NOTICE: Ensure threaded holes are free of contamination and debris. Failure to clean threaded holes results in a damaged housing when cap screws are installed.

7. Carefully install Rail B Shift Yoke assembly into Rail B cylinder.

Note: Ensure assembly is fully seated into cylinder.

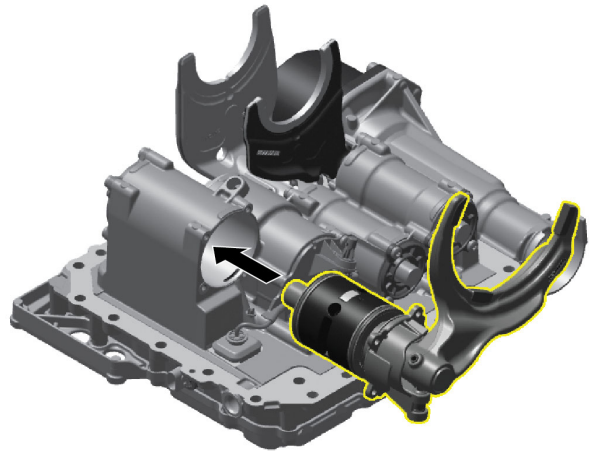

8. Install Countershaft Speed Sensor.

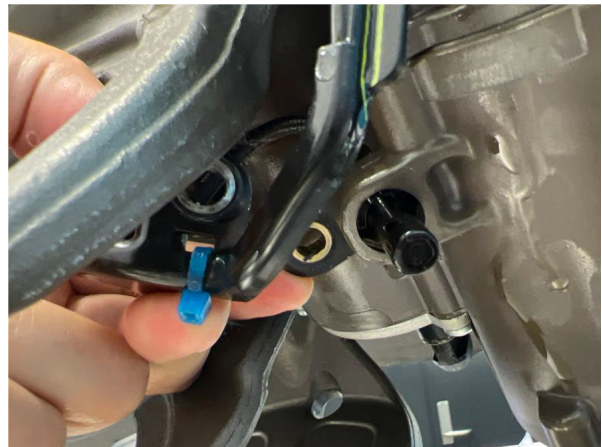

9. Install Countershaft Speed Sensor harness.



10. Clean 4 Rail B Shift Yoke Cylinder Cover T30 cap screws (M6x25) with parts cleaner.
11. Apply thread lock as indicated.

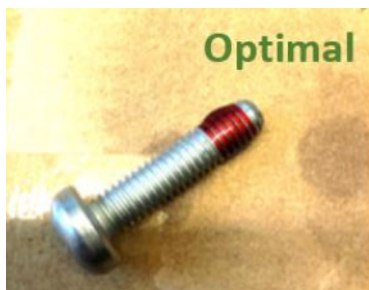

12. Install 4 Rail B Shift Yoke Cylinder Cover T30 cap screws (1, 2, 3, 4 - M6x25).
13. Torque to 9.5-10.5 Nm (84-92 in lbs.) in a crisscross pattern.

14. Re-torque bottom two cap screws to 11-12 Nm (97-106 in lbs.).

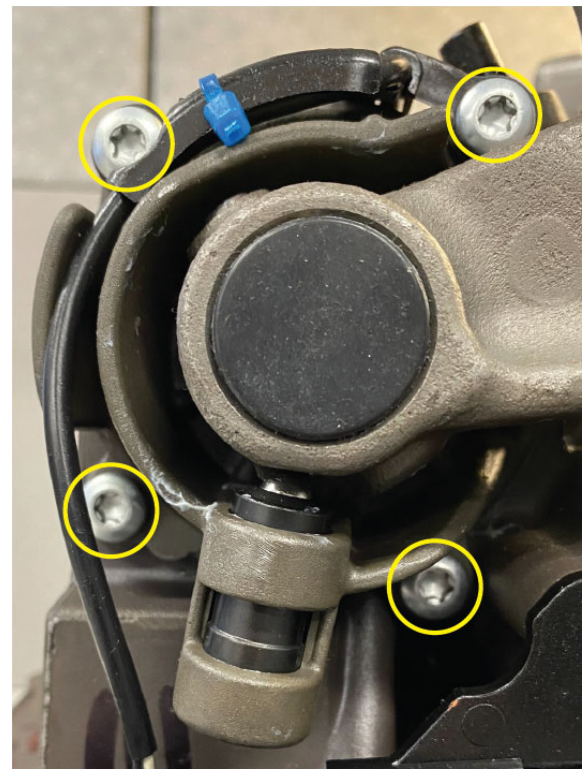

15. Clean 1 Countershaft Speed Sensor T30 cap screw (M6x25) with parts cleaner.
16. Apply thread lock as indicated.

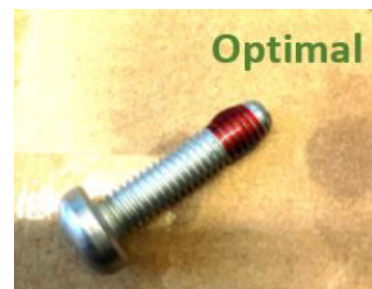

17. Install 1 (5) Countershaft Speed Sensor T30 cap screw (M6x25).

18. Torque to 9.5-10.5 Nm (84-92 in lbs.).

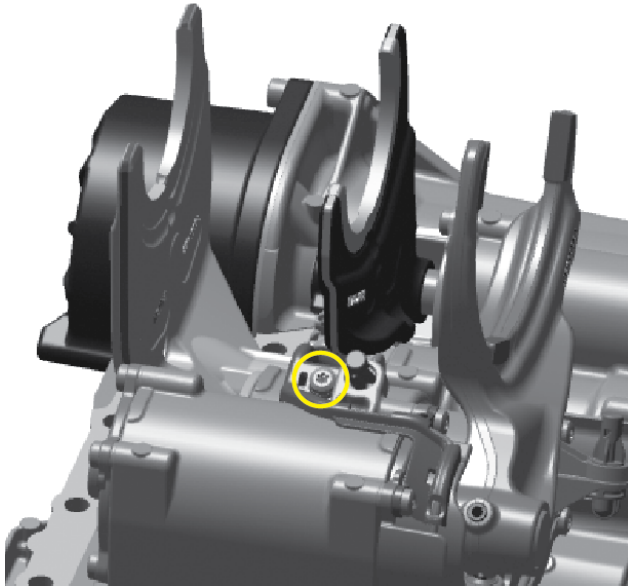

Disassemble Rail C and D

1. Place MTM on a clean surface.

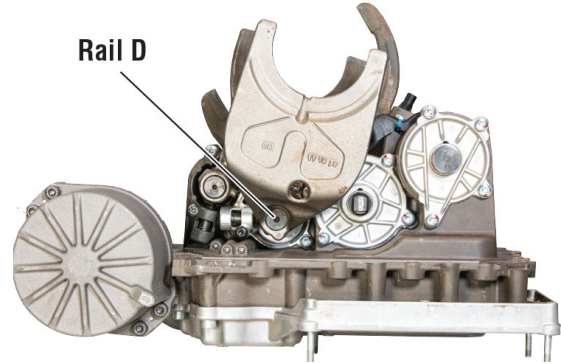

2. Move Shift Rails C and D in the MTM to neutral. Rails C and D are in neutral when the shift inter-lock is aligned with the notches of the rail yoke assemblies.

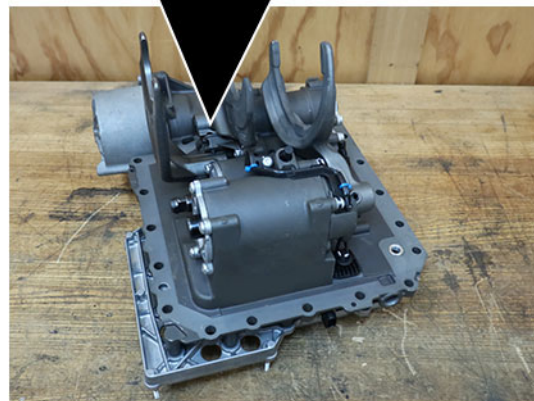

- Remove 3 Rail D Shift Yoke Cylinder Cover T30 cap screws (1 - M6x65, 2 - M6x25).

Note: Rotate Rail D Shift Yoke to access upper right cap screw.

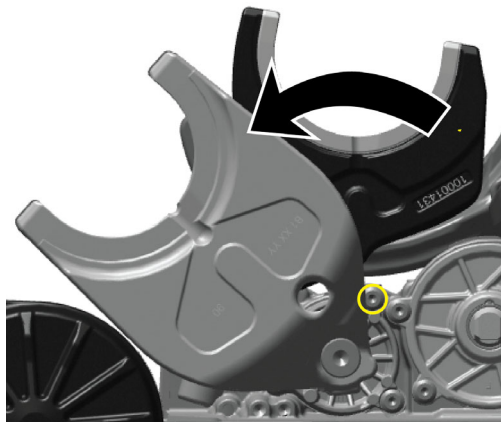
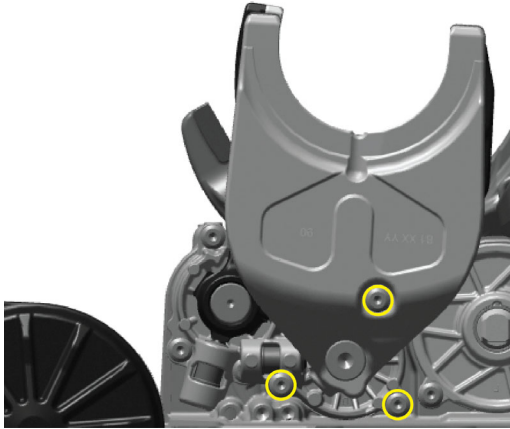

- Firmly grasp and remove Rail D Shift Yoke assembly from cylinder.

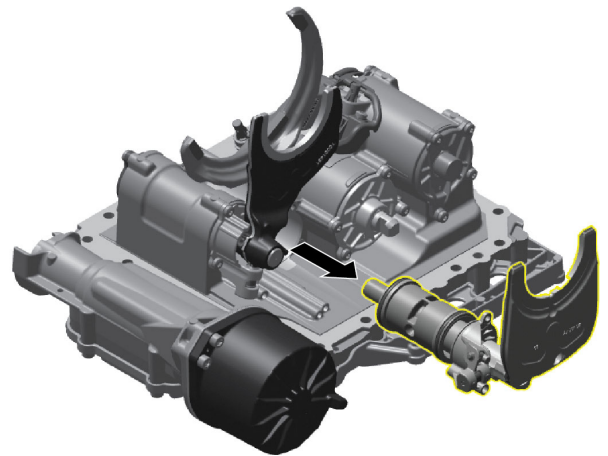

- Place Rail D Shift Yoke assembly on a clean surface.
- Remove Rail C and D Shift Inter-lock Pin.

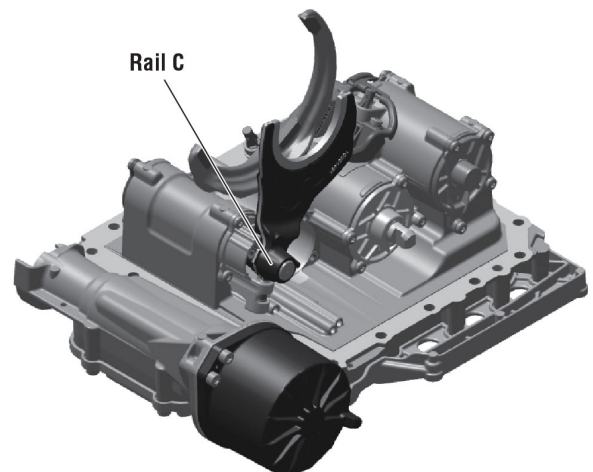

7. Remove 3 Rail C Shift Yoke Cylinder Cover T30 cap screws (4, 5, 6 M6x25).



9. Place Rail C Shift Yoke assembly on a clean surface.



8. Firmly grasp and remove Rail C Shift Yoke assembly from cylinder.

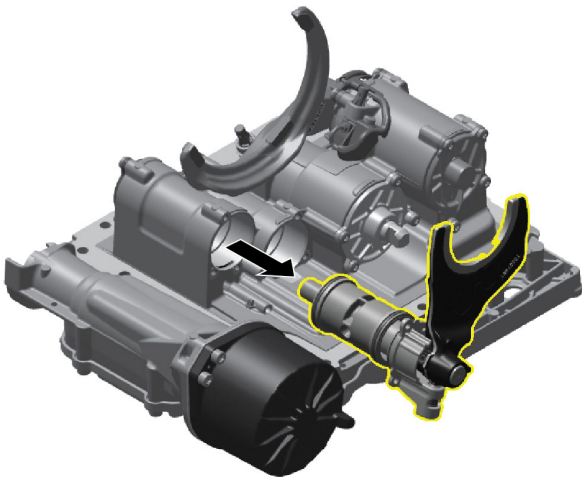

Assemble Rail C and D

1. Remove Rail D Shift Yoke cover O-ring from cover groove.



2. Slide O-ring over piston assembly.

Note: Do not damage or remove piston O-ring.



3. Lubricate new Rail D Shift Yoke cover O-ring 47mm (1.85 inches) with PS-386 HD Synthetic Transmission Lubricant.

4. Install new Rail D Shift Yoke cover O-ring, slide over piston assembly and into cover groove.

Note: Ensure O-ring is fully seated in groove.



5. Remove Rail C Shift Yoke cover O-ring from cover groove.



6. Slide O-ring over piston assembly.

Note: Do not damage or remove piston O-ring.

7. Lubricate new Rail C Shift Yoke cover O-ring 47mm (1.85 inches) with PS-386 HD Synthetic Transmission Lubricant.

8. Install new Rail C Shift Yoke cover O-ring, slide over piston assembly and into cover groove.

Note: Ensure O-ring is fully seated in groove.



9. Inspect Rail C and D cylinders for contamination. Remove any contamination and excessive oil with a lint-free cloth.

Note: Do not remove residual cylinder lubricant. If necessary, lightly lubricate cylinder with PS-386 HD Synthetic Transmission Lubricant.



10. Clean Rail C and D cylinder cover threaded holes with parts cleaner.

NOTICE: Ensure threaded holes are free of contamination and debris. Failure to clean threaded holes results in a damaged housing when cap screws are installed.

11. Carefully install Rail C Shift Yoke assembly into Rail C cylinder.

Note: Ensure assembly is fully seated into cylinder.

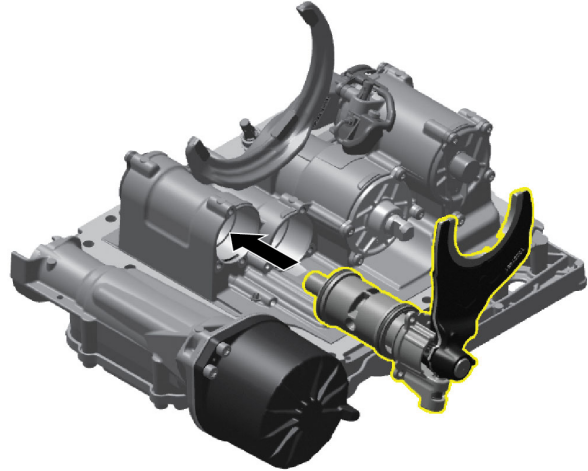

12. Clean 3 Rail C Shift Yoke Cylinder Cover T30 cap screws (M6x25) with parts cleaner.

13. Apply thread lock as indicated.

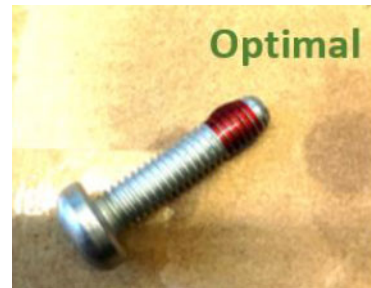

14. Install 3 Rail C Shift Yoke Cylinder Cover T30 cap screws (4, 5, 6 - M6x25).

- 15. Torque to 11-12 Nm (97-106 in lbs.) in a crisscross pattern.



- 16. Install Rail C and D Shift Inter-lock Pin. Apply transmission assembly lube to hold pin in place.



CAUTION: Ensure to install Rail C and D Shift Inter-lock Pin. Failure to install inter-lock pin could result in transmission component damage.

- 17. Move Shift Rail C Shift Yoke to neutral and align Shift Inter-lock Pin to groove.

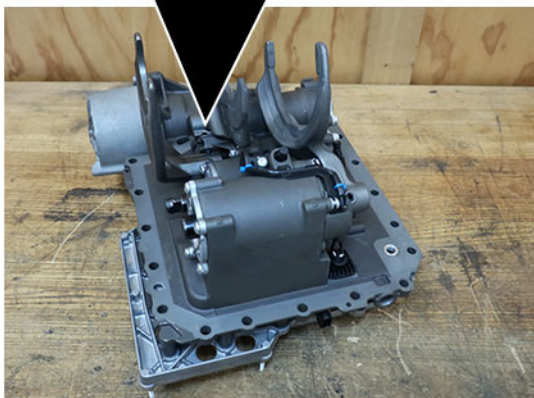
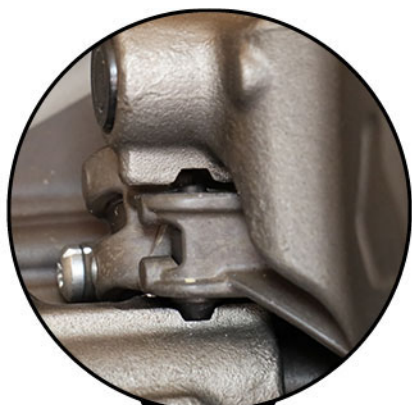

- 18. Carefully install Rail D Shift Yoke assembly into Rail D cylinder.

Note: Ensure assembly is fully seated into cylinder.

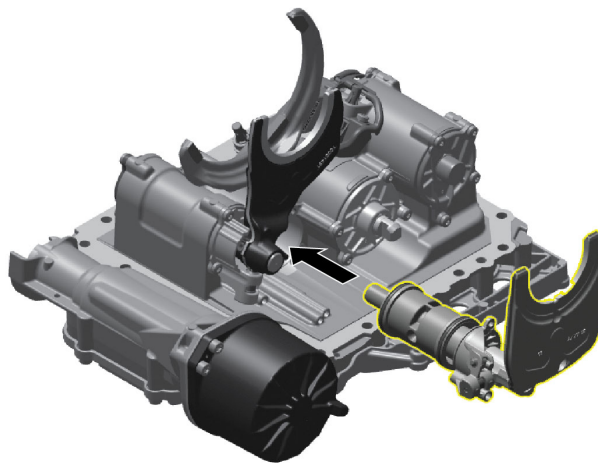

- 19. Clean 3 Rail C Shift Yoke Cylinder Cover T30 cap screws (M6x25) with parts cleaner.

- 20. Apply thread lock as indicated.



- 21. Install 3 Rail C Shift Yoke Cylinder Cover T30 cap screws (1 - M6x65, 2, 3 - M6x25).

22. Torque to 11-12 Nm (97-106 in lbs.) in a crisscross pattern.

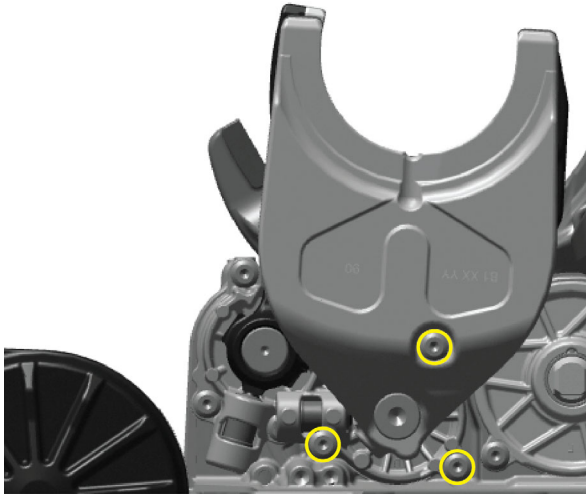

23. Determine next step.

- If guided here by MTM Rail B, C and D Cylinder Inspection Procedure due to Fault Code 617, 740, 760, 775:
 - If Fault Code 617, go to Procedure A.
 - If Fault Code 740, go to Procedure B.
 - If Fault Code 760, go to Procedure C.
 - If Fault Code 775, go to Procedure D.
- If guided here by MTM Rail B, C and D Cylinder Inspection Procedure and no fault codes were originally set, process complete.

Procedure A

STEP A

Purpose: Verify mechanical condition of the Secondary Driven Gear

1. Inspect the Secondary Driven Gear for excessive for and aft movement.
 - If excessive gear movement is evident, inspect the Main Shaft Assembly and Secondary Driven Gear and repair. Go to Step V.
 - If no excessive gear movement is evident, go to Procedure A, Step B.

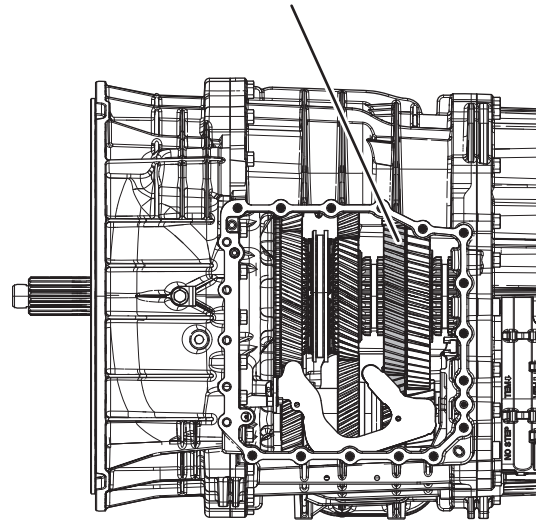

Procedure A

STEP B

Purpose: Verify mechanical condition of the Rail C Sliding Clutch and clutching teeth.

1. Inspect the Rail C Sliding Clutch yoke for wear.

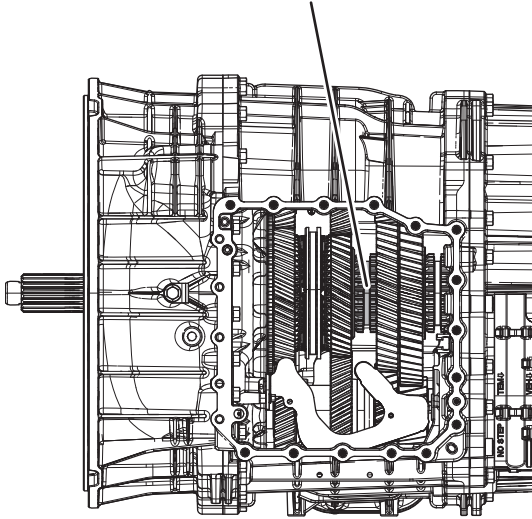

2. Shift the Rail C Sliding Clutch to the neutral position (if necessary).
3. Shift the Rail C Sliding Clutch into the Primary Drive Gear engagement position (fore).
4. Inspect the Rail C Sliding Clutch clutching teeth for wear.
5. Return the Rail C Sliding Clutch to neutral.
6. Shift the Rail C Sliding Clutch into the Secondary Driven Gear engagement position (aft).
7. Inspect the Rail C Sliding Clutch clutching teeth for wear.
8. Return the Rail C Sliding Clutch to neutral.
 - If the Rail C Sliding Clutch shifts into all three positions and no clutching teeth wear is present, process complete. Go to Step V.
 - If the Rail C Sliding Clutch does not shift into all three positions or clutching teeth wear is present, reference Primary Drive Gear Replacement procedure for replacing the Primary Drive Gear and Rail C Sliding Clutch, and Secondary Driven Gear. Go to Step V.

Procedure B

STEP A

Purpose: Verify mechanical condition of the Primary and Secondary Drive Gears.

1. Inspect the Secondary Drive Gear for excessive fore and aft movement.

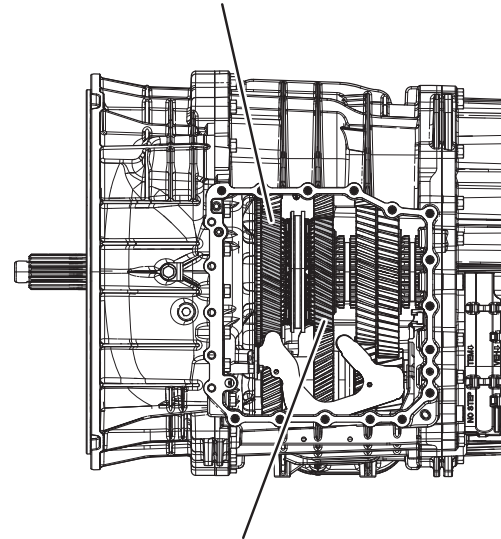

2. Inspect the Primary Drive Gear for excessive fore and aft movement.
 - If excessive gear movement is evident, inspect for cause of excessive gear movement and repair. Go to Step V.
 - If no excessive gear movement is evident, go to Procedure B, Step B.

Procedure B

STEP B

Purpose: Verify mechanical condition of the Rail B Synchronizer and clutching teeth.

1. Inspect the Rail B Synchronizer Sliding Sleeve yoke slot for wear.

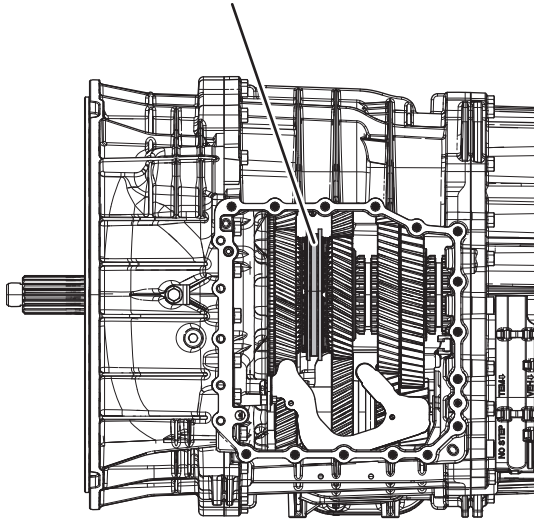

2. Install the Rail B Synchronizer Engagement Tool (RR1088TR).

Note: Reference Appendix, Manually Actuate Rail B Procedure.
3. Shift Rail B Synchronizer Sliding Sleeve into neutral (if necessary).
4. Shift the Rail B Synchronizer Sliding Sleeve into the Secondary Drive Gear engagement position (fore).
5. Inspect the Primary Drive Gear and synchronizer ring clutching teeth for wear.
6. Return the Rail B Synchronizer Sliding Sleeve to neutral.
7. Shift the Rail B Synchronizer Sliding Sleeve into the Primary Drive Gear engagement position (aft).
8. Inspect the Secondary Drive Gear and synchronizer ring clutching teeth for wear.

9. Return the Rail B Synchronizer Sliding Sleeve to neutral.
 - If the Rail B Synchronizer Sliding Sleeve shifts into all three positions and no clutching teeth wear is present, process complete. Go to Step V.
 - If the Rail B Synchronizer Sliding Sleeve does not shift into all three positions or clutching teeth wear is present, reference the Primary Drive Gear Replacement procedure for replacement of the Primary Drive Gear. Replace the Rail B Synchronizer Assembly and the Secondary Drive Gear. Go to Step V.

Procedure C

STEP A

Purpose: Verify mechanical condition of the Primary Drive Gear and Secondary Driven Gear.

1. Inspect the Primary Drive Gear for excessive fore and aft movement.

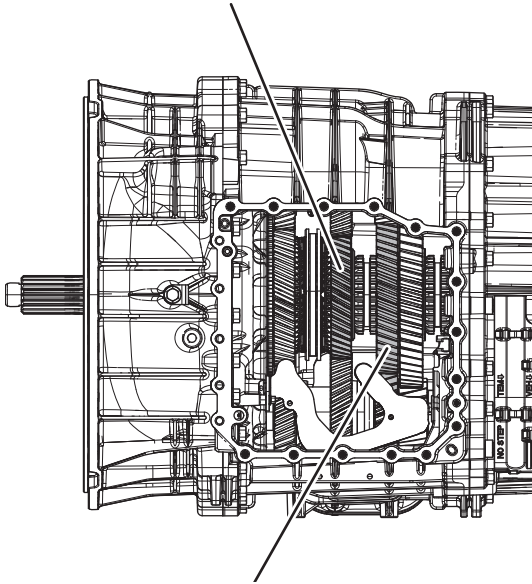

2. Inspect the Secondary Driven Gear for excessive fore and aft movement.
 - If excessive gear movement is evident, inspect for cause of excessive gear movement and repair. Go to Step V.
 - If no excessive gear movement is evident, go to Procedure C, Step B.

Procedure C

STEP B

Purpose: Verify mechanical condition of the Rail C Sliding Clutch and clutching teeth.

1. Inspect the Rail C Sliding Clutch yoke slot for wear.

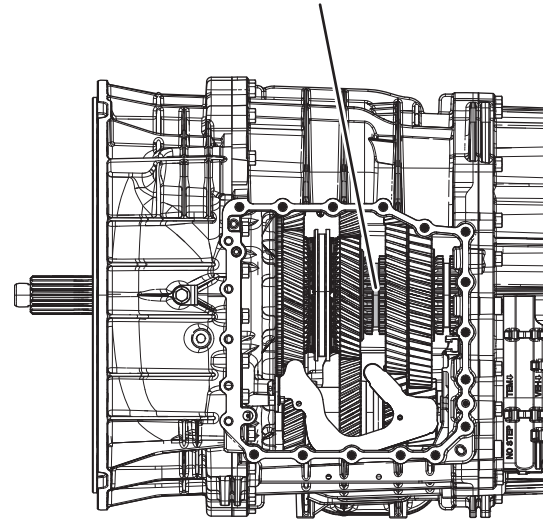

2. Shift the Rail C Sliding Clutch to the neutral position (if necessary).
3. Shift the Rail C Sliding Clutch into the Primary Drive Gear engagement position (fore).
4. Inspect the Rail C Sliding Clutch clutching teeth for wear.
5. Return the Rail C Sliding Clutch to neutral.
6. Shift the Rail C Sliding Clutch into the Secondary Driven Gear engagement position (aft).
7. Inspect the Rail C Sliding Clutch clutching teeth for wear.
8. Return the Rail C Sliding Clutch to neutral.
 - If the Rail C Sliding Clutch shifts into all three positions and no clutching teeth wear is present, process complete. Go to Step V.
 - If the Rail C Sliding Clutch does not shift into all three positions or clutching teeth wear is present, refer to the Primary Drive Gear Replacement procedure for replacing the Primary Drive Gear and Rail C Sliding Clutch, and Secondary Driven Gear. Go to Step V.

Procedure D

STEP A

Purpose: Verify mechanical condition of the Primary Driven Gear and Reverse Gear

1. Inspect the Primary Driven Gear for excessive fore and aft movement.

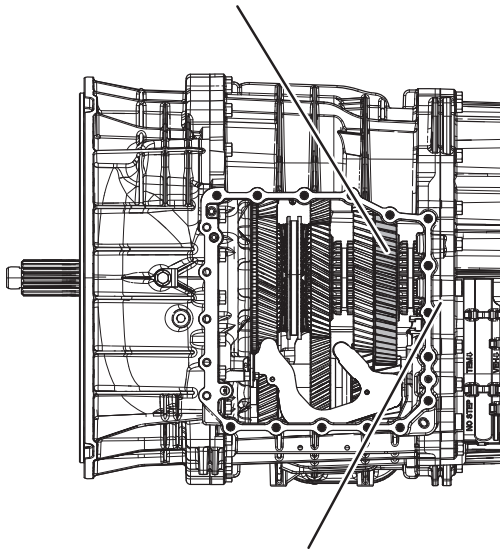

2. Inspect the Reverse Gear for excessive fore and aft movement.
 - If excessive gear movement is evident, inspect for cause of excessive gear movement and repair. Go to Step V.
 - If no excessive gear movement is evident, go to Procedure D, Step B.

Procedure D

STEP B

Purpose: Verify mechanical condition of the Rail D Sliding Clutch and clutching teeth.

1. Inspect the Rail D Sliding Clutch yoke slot for wear.

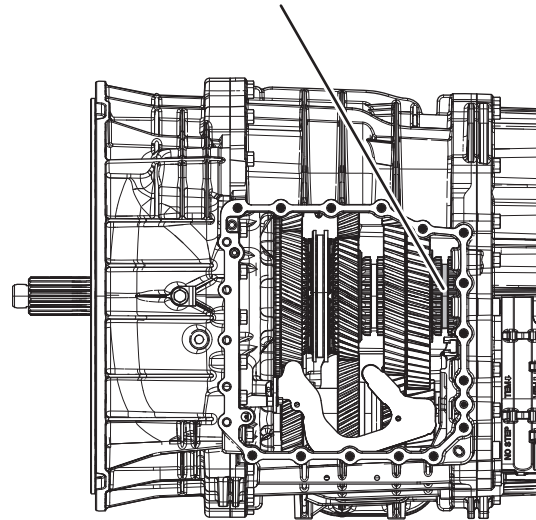

2. Shift the Rail D Sliding Clutch to the neutral position (if necessary).
3. Shift the Rail D Sliding Clutch into the Primary Driven Gear engagement position (fore).
4. Inspect the Rail D Sliding Clutch clutching teeth for wear.
5. Return the Rail D Sliding Clutch to neutral.
6. Shift the Rail D Sliding Clutch into the Reverse Gear engagement position (aft).
7. Inspect the Rail D Sliding Clutch clutching teeth for wear.
8. Return the Rail D Sliding Clutch to neutral.
 - If the Rail D Sliding Clutch shifts into all three positions and no clutching teeth wear is present, process complete. Go to Step V.
 - If the Rail D Sliding Clutch does not shift into all three positions or clutching teeth wear is present, replace the Rail D Sliding Clutch, Primary Driven Gear and Reverse Gear. Go to Step V.

STEP V

Purpose: Verify Repair.

1. Key off.
2. Reconnect all connectors and verify that all components are properly installed.
3. Key on with engine off.
4. Connect ServiceRanger.
5. Go to “Fault Codes”.
6. Select “Clear All Faults”.
7. Operate vehicle and attempt to reset the fault code or duplicate the previous complaint.
8. Check for fault codes using ServiceRanger.
 - If no fault codes set and the vehicle operates properly, test complete.
 - If Fault Code 617, 740, 760, 775 sets Active during operation, contact Eaton Cummins Automated Transmission Technologies for further diagnostic instructions. For Help Line phone numbers, go to “Contact Information” on page 4.
 - If a fault code other than 617, 740, 760, 775 sets Active, go to Endurant HD Troubleshooting Guide and troubleshoot per the Fault Code Isolation Procedure Index.

Warranty Information

1. Reference the relevant warranty information provided in service bulletin **TAIB-0994**.

MTM Rail B, C and D Cover Cap Screw

Special Instructions

- Perform this entire procedure only:
 - If guided here by MTM Rail B, C and D Cylinder Inspection Procedure.
 - If guided here by **TAIB-0994** - MTM was removed for another transmission related issue and MTM Serial Number is less than 12S22342093445.
- Reference the relevant warranty information provided in service bulletin **TAIB-0994**.

Special Tools

- T30 Torx Bit
- Torque Wrench - Nm (in lbs.)
- Parts Cleaner (Loctite SF 7063 or equivalent)
- Thread Lock (Loctite® 262™ Threadlocker Red or equivalent)



CAUTION: Only use items outlined above. Failure to follow these instructions could result in MTM damage.

Component Identification

MTM, Fore view

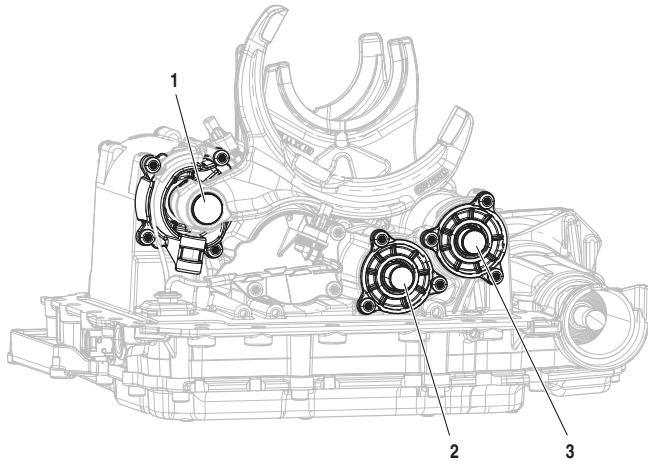

MTM, Aft view

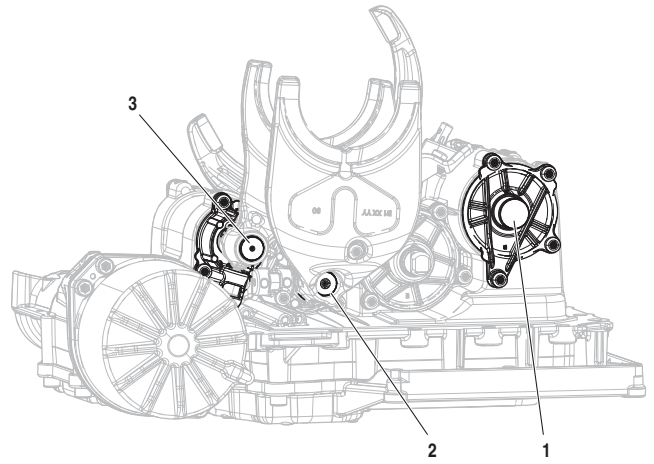

- 1. MTM Rail B
- 2. MTM Rail D
- 3. MTM Rail C

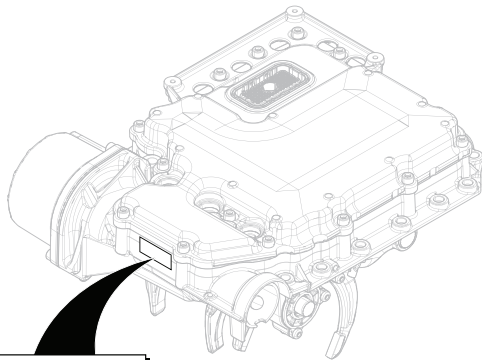

| | | |
|---|-------------------|---|
|  | EATON | 1 |
| | A-10000715 R-A | |
| | V: KA | |
| | S: 12S20051163732 | 2 |

- 1. Part Number
- 2. Serial Number

Procedure - Rail B

1. Place MTM on a clean surface.

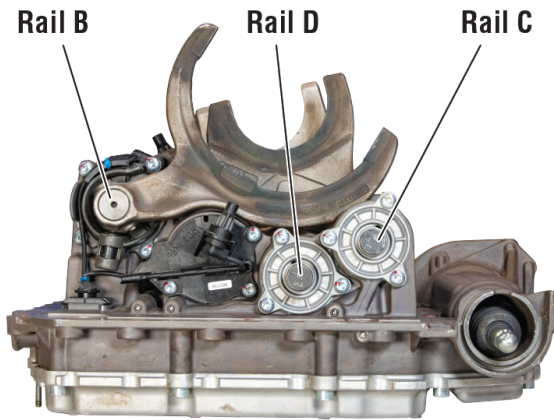

2. Remove 2 Rail B Shift Yoke Cylinder Cover T30 cap screws (1, 2 - M6x65).

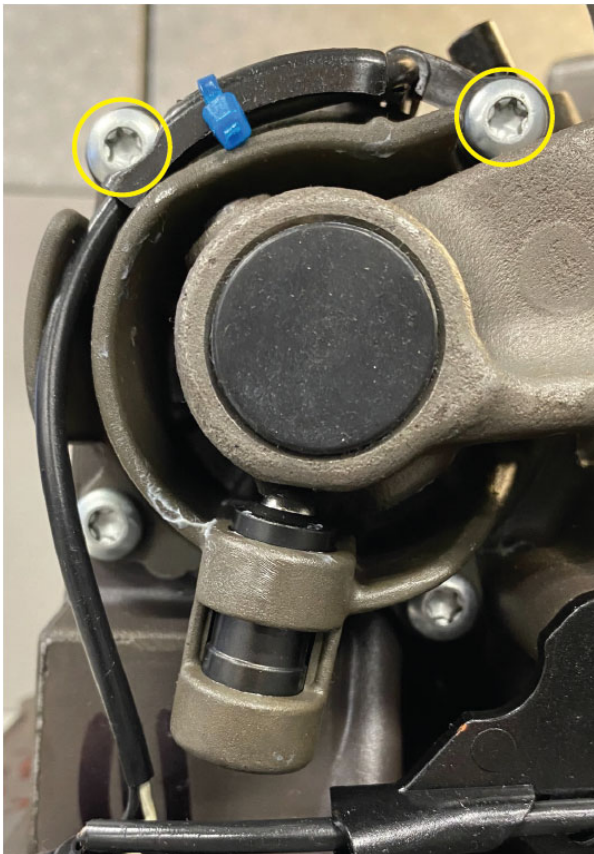

3. Remove 1 Countershaft Speed Sensor T30 cap screw (5 - M6x65).

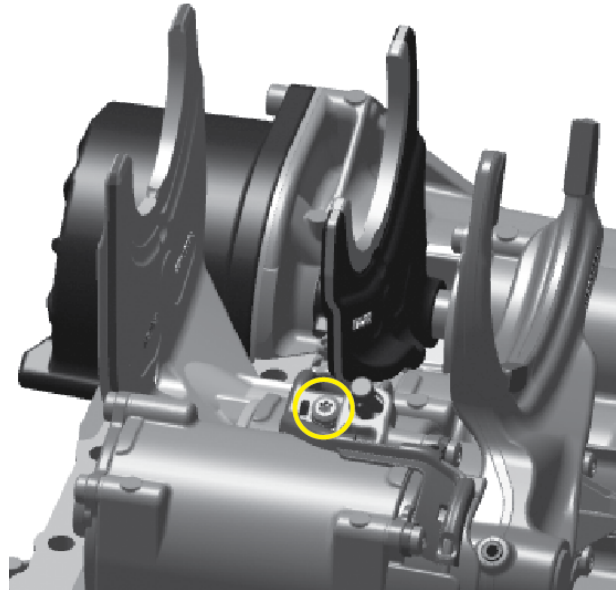

4. Rotate Countershaft Speed Sensor clockwise 90 degrees.

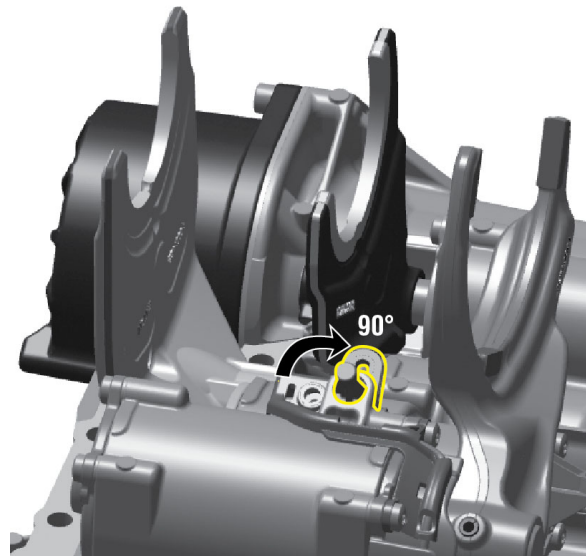

- Remove Countershaft Speed Sensor from housing.

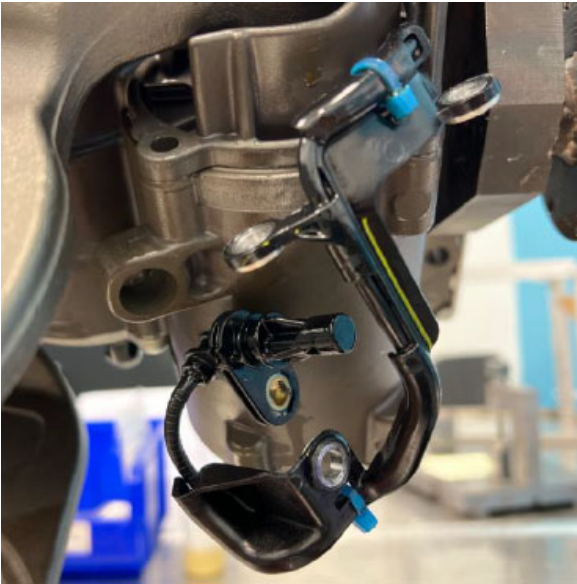

- Install Countershaft Speed Sensor harness.

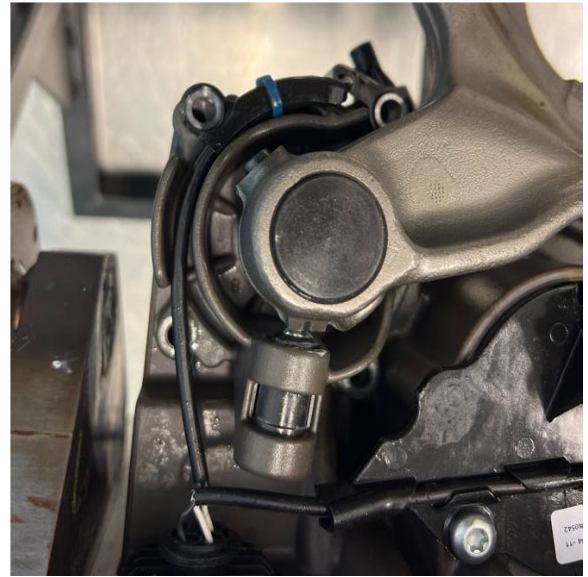

- Clean Rail B Shift Yoke Cylinder Cover threaded holes with parts cleaner.

NOTICE: Ensure threaded holes are free of contamination and debris. Failure to clean threaded holes results in a damaged housing when cap screws are installed.

- Clean Countershaft Speed Sensor threaded hole with parts cleaner.

NOTICE: Ensure threaded holes are free of contamination and debris. Failure to clean threaded holes results in a damaged housing when cap screws are installed.

- Install Countershaft Speed Sensor.



- Clean 2 Rail B Shift Yoke Cylinder Cover T30 cap screws (M6x25) with parts cleaner.

- Apply thread lock as indicated.

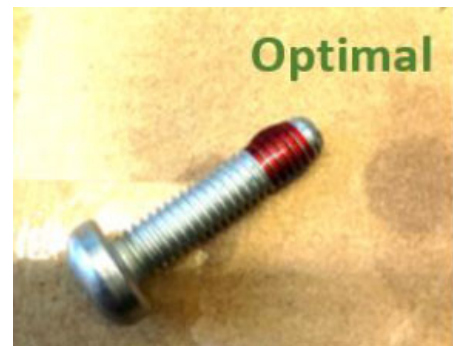

- Install 2 Rail B Shift Yoke Cylinder Cover T30 cap screws (1, 2 - M6x25).

13. Torque cap screws (1, 2) to 9.5-10.5 Nm (84-92 in lbs.).

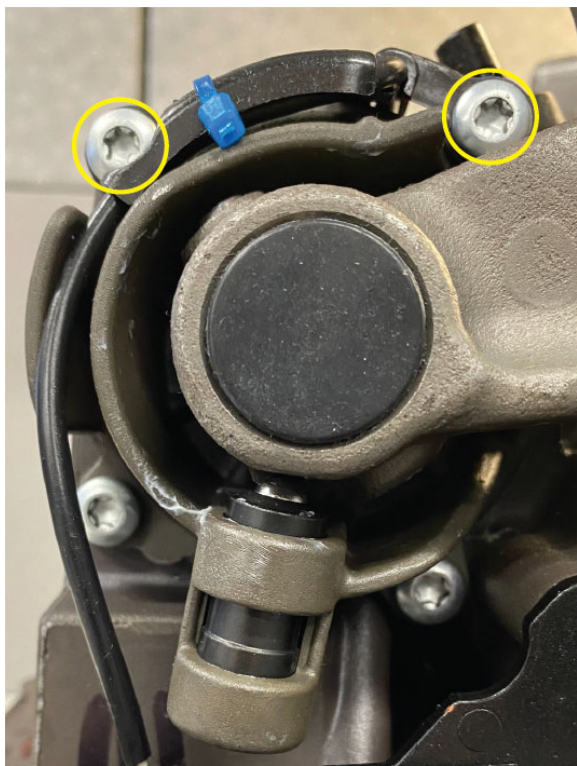

14. Clean 1 Countershaft Speed Sensor T30 cap screws (M625) with parts cleaner.
 15. Apply thread lock as indicated.

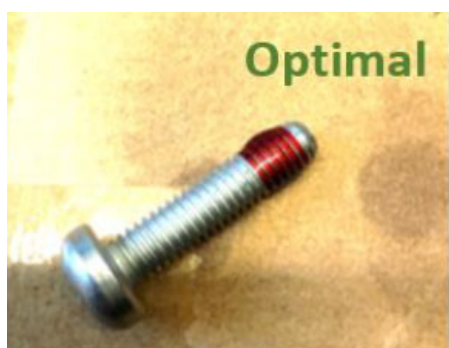

16. Install 1 (5) Countershaft Speed Sensor T30 cap screws (M6x25).

17. Torque to 9.5-10.5 Nm (84-92 in lbs.).

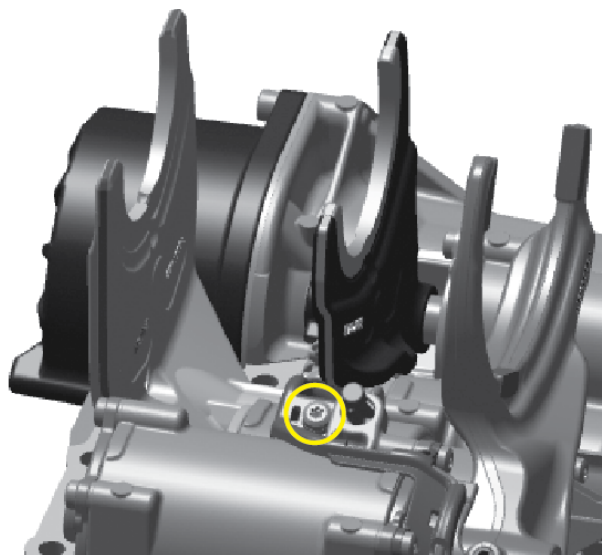

18. Remove 2 Rail B Shift Yoke Cylinder Cover T30 cap screws (3, 4 - M6x65).

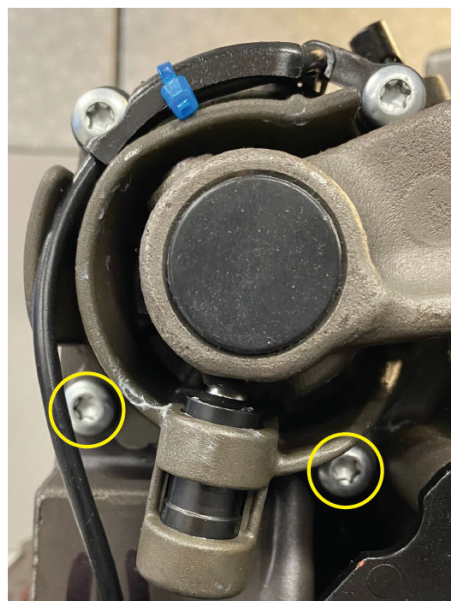

19. Clean Rail B Shift Yoke Cylinder Cover threaded holes with parts cleaner.

NOTICE: Ensure threaded holes are free of contamination and debris. Failure to clean threaded holes results in a damaged housing when cap screws are installed.

20. Clean 2 Rail B Shift Yoke Cylinder Cover T30 cap screws (M6x25) with parts cleaner.

21. Apply thread lock as indicated.



22. Install 2 Rail B Shift Yoke Cylinder Cover T30 cap screws (3, 4 - M6x25).
23. Torque cap screws (3, 4) to 11-12 Nm (97-106 in lbs.).

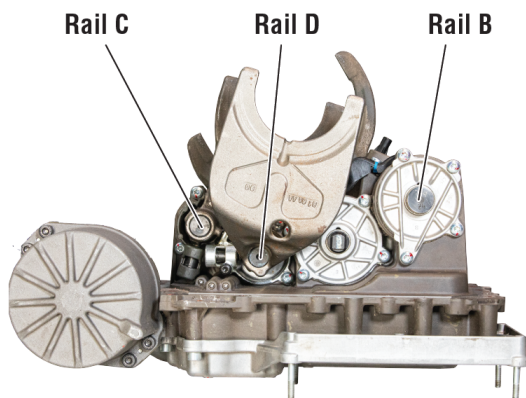
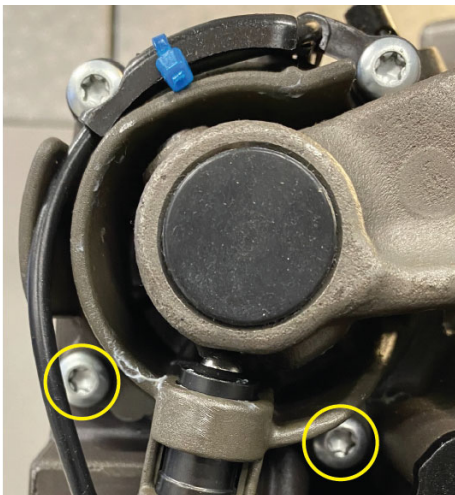

24. Remove 4 Rail B Cylinder Cover T30 cap screws (M6x65).

Note: Remove, clean, apply thread lock and reinstall one cap screw at a time.



25. Clean Rail B Cylinder Cover threaded holes with parts cleaner.

NOTICE: Ensure threaded holes are free of contamination and debris. Failure to clean threaded holes results in a damaged housing when cap screws are installed.

26. Clean 4 Rail B Cylinder Cover T30 cap screws (M6x25) with parts cleaner.

27. Apply thread lock as indicated.

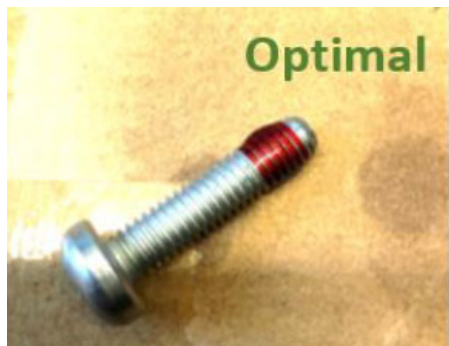

28. Install 4 Rail B Cylinder Cover T30 cap screws (M6x25).

29. Torque to 11-12 Nm (97-106 in lbs.).



Procedure - Rail C

1. Remove 2 Rail C Shift Yoke Cylinder Cover T30 cap screws (M6x25)

Note: Remove, clean, apply thread lock and reinstall one cap screw at a time.

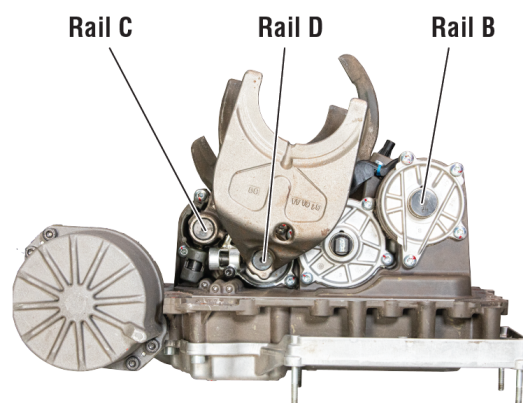
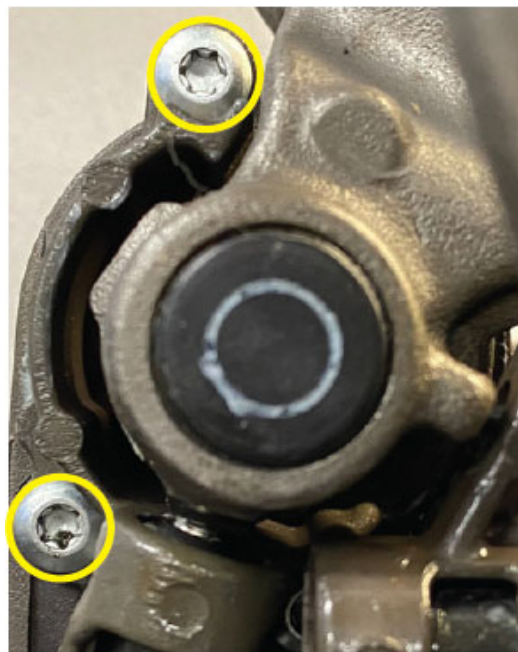

2. Clean Rail C Cylinder Cover threaded holes with parts cleaner.

NOTICE: Ensure threaded holes are free of contamination and debris. Failure to clean threaded holes results in a damaged housing when cap screws are installed.

3. Clean 2 Rail C Shift Yoke Cylinder Cover T30 cap screws (M6x25) with parts cleaner.

4. Apply thread lock as indicated.

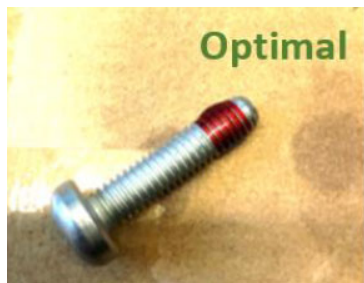

5. Install 2 Rail C Shift Yoke Cylinder Cover T30 cap screws.
6. Torque to 11-12 Nm (97-106 in lbs.).

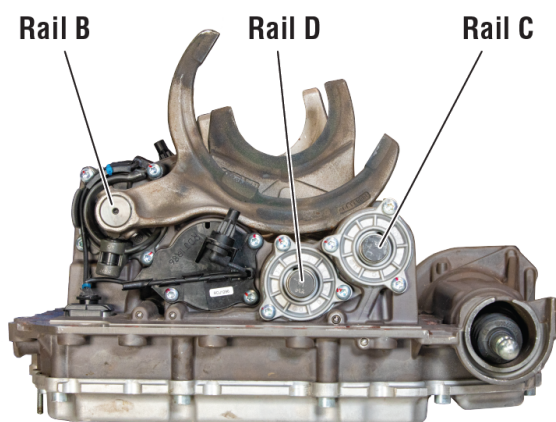
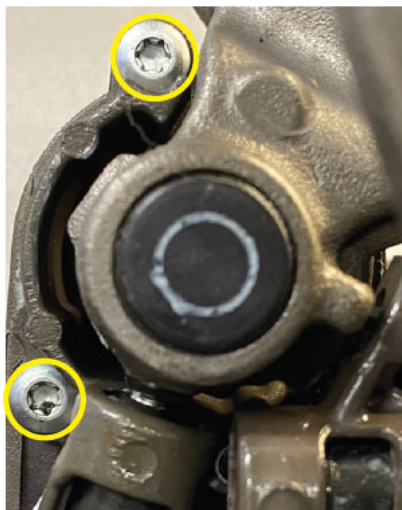

7. Remove 3 Rail C Cylinder Cover T30 cap screws (M6x65).

Note: Remove, clean, apply thread lock and reinstall one cap screw at a time.

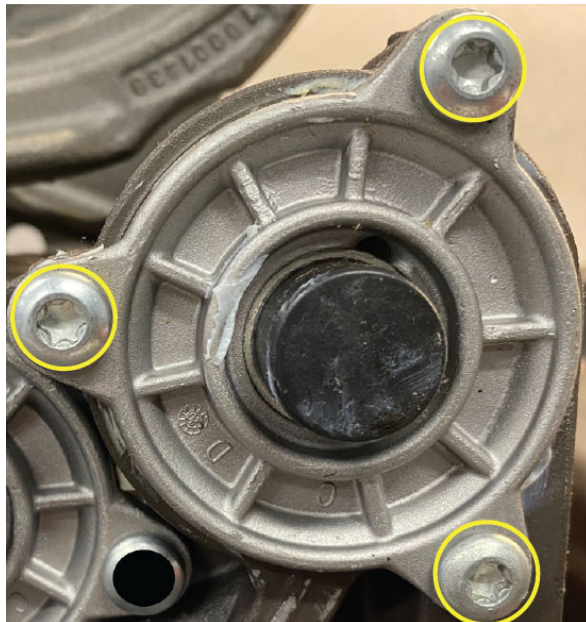

8. Clean Rail C Cylinder Cover threaded holes with parts cleaner.

NOTICE: Ensure threaded holes are free of contamination and debris. Failure to clean threaded holes results in a damaged housing when cap screws are installed.

9. Clean 3 Rail C Cylinder Cover T30 cap screws (M6x25) with parts cleaner.
10. Apply thread lock as indicated.

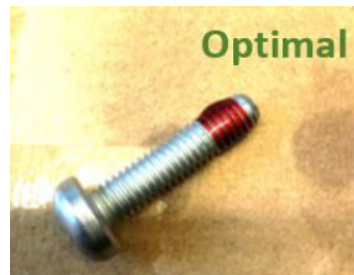

11. Install 3 Rail C Cylinder Cover T30 cap screws.

12. Torque to 11-12 Nm (97-106 in lbs.).

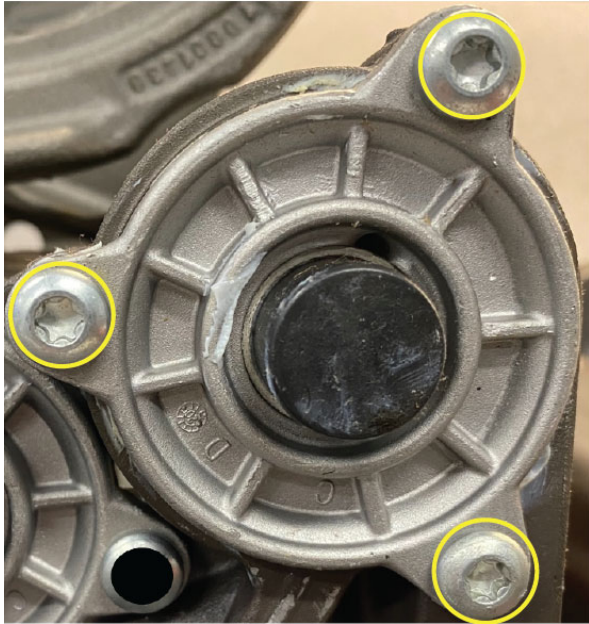

Procedure - Rail D

1. Move Shift Rails C and D in the MTM to neutral. Rails C and D are in neutral when the shift inter-lock is aligned with the notches of the rail yoke assemblies.

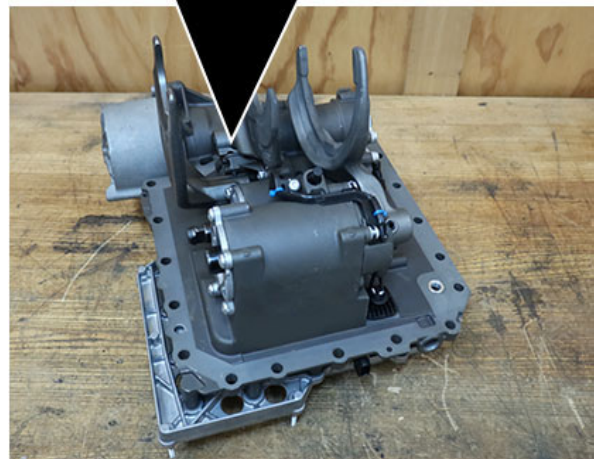
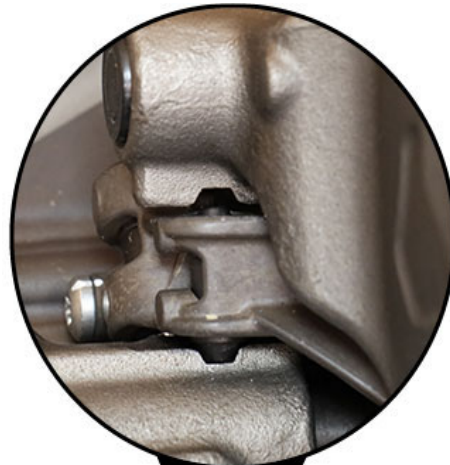
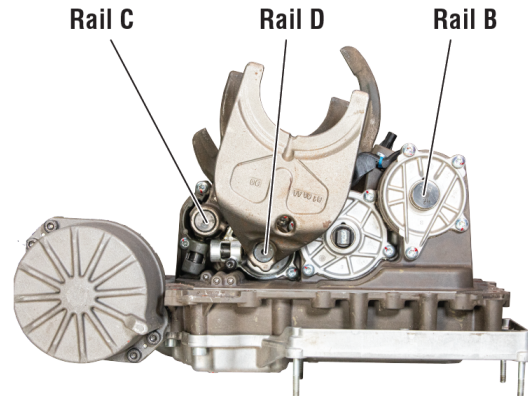

- Remove 3 Rail D Shift Yoke Cylinder Cover T30 cap screws (1 - M6x65, 2, 3 - M6x25).

Note: Remove, clean, apply thread lock and reinstall one cap screw at a time.

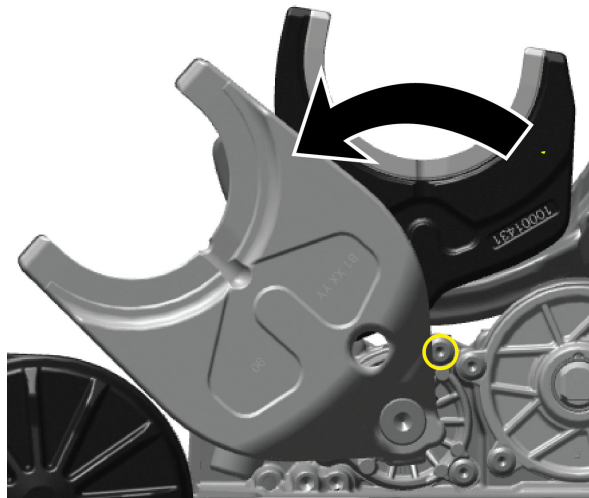
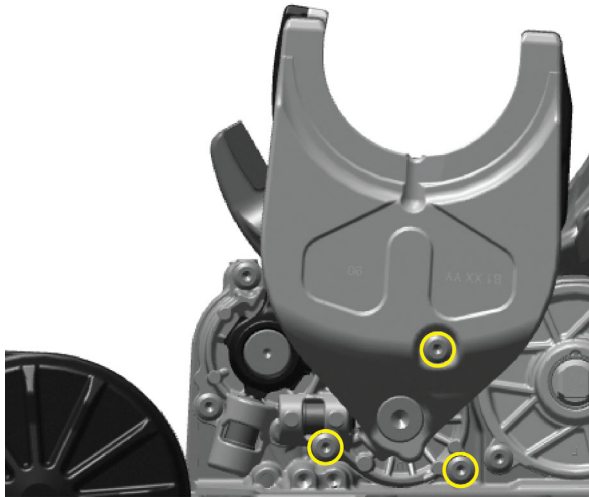

- Clean Rail D Shift Yoke Cylinder Cover threaded holes with parts cleaner.

NOTICE: Ensure threaded holes are free of contamination and debris. Failure to clean threaded holes results in a damaged housing when cap screws are installed.

- Clean 3 Rail D Shift Yoke Cylinder Cover T30 cap screws (1 - M6x65, 2, 3 - M6x25) with parts cleaner.

- Apply thread lock as indicated.



- Install 3 Rail D Shift Yoke Cylinder Cover T30 cap screws (1 - M6x65, 2, 3 - M6x25).

- Torque to 11-12 Nm (97-106 in lbs.).

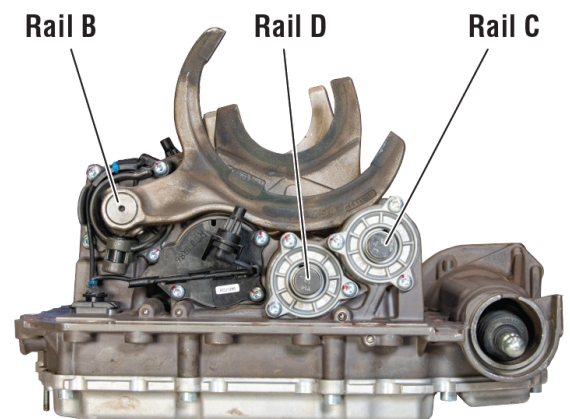
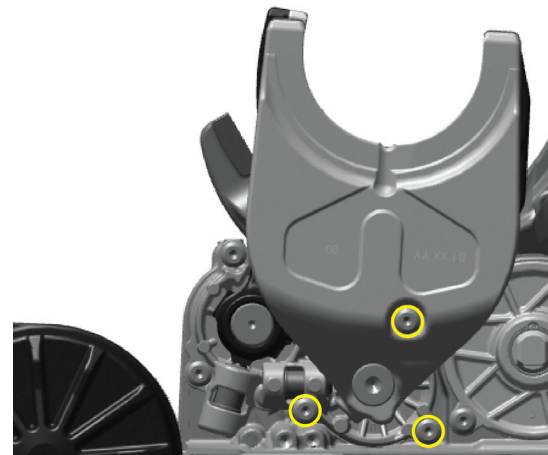

8. Remove 3 Rail D Cylinder Cover T30 cap screws (M6x65).

Note: Remove, clean, apply thread lock and reinstall one cap screw at a time.

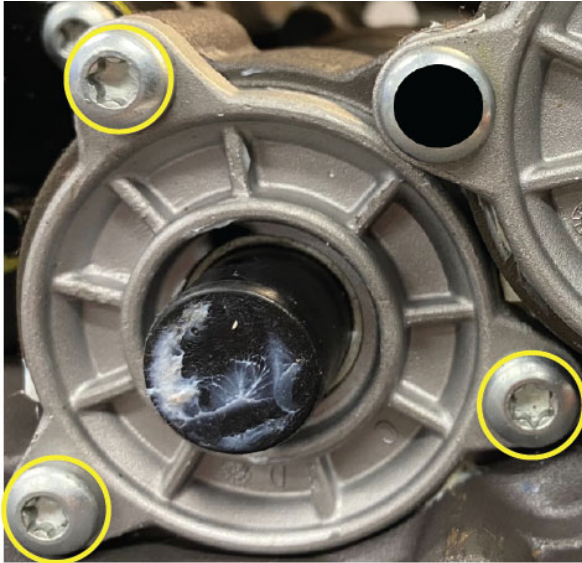

9. Clean Rail D Cylinder Cover threaded holes with parts cleaner.

NOTICE: Ensure threaded holes are free of contamination and debris. Failure to clean threaded holes results in a damaged housing when cap screws are installed.

10. Clean 3 Rail D Cylinder Cover T30 cap screws (M6x25) with parts cleaner.
11. Apply thread lock as indicated.

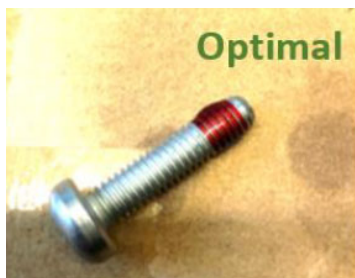

12. Install 3 Rail D Cylinder Cover T30 cap screws.

13. Torque to 11-12 Nm (97-106 in lbs.).

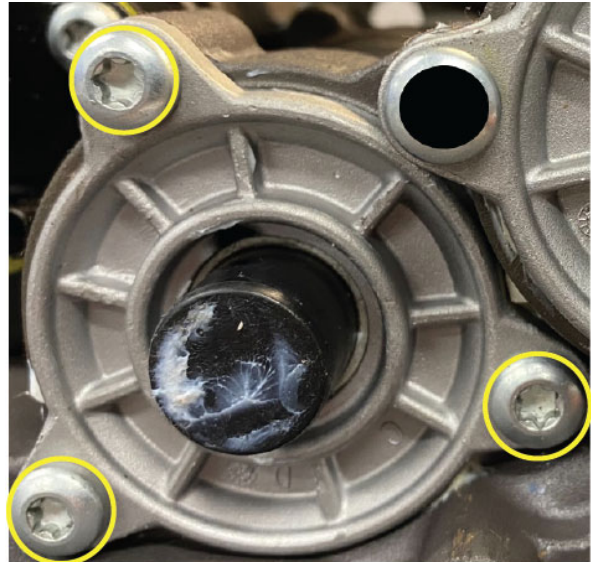

14. Determine next step.

- If guided here by MTM Rail B, C and D Cylinder Inspection Procedure due to Fault Code 617, 740, 760, 775:
 - If Fault Code 617, go to Procedure A.
 - If Fault Code 740, go to Procedure B.
 - If Fault Code 760, go to Procedure C.
 - If Fault Code 775, go to Procedure D.
- If guided here by MTM Rail B, C and D Cylinder Inspection Procedure and no fault codes were originally set, process complete.
- If guided here by **TAIB-0994** - MTM was removed for another transmission related issue, process complete.

Procedure A

STEP A

Purpose: Verify mechanical condition of the Secondary Driven Gear

1. Inspect the Secondary Driven Gear for excessive for and aft movement.
 - If excessive gear movement is evident, inspect the Main Shaft Assembly and Secondary Driven Gear and repair. Go to Step V.
 - If no excessive gear movement is evident, go to Procedure A, Step B.

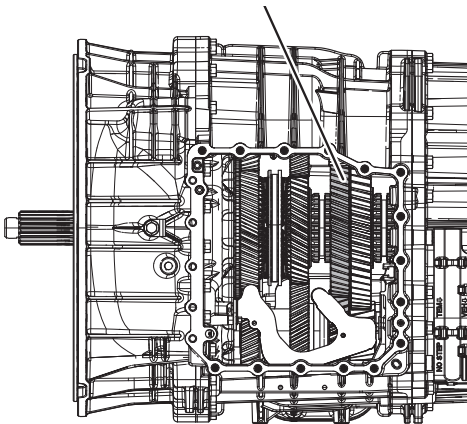

Procedure A

STEP B

Purpose: Verify mechanical condition of the Rail C Sliding Clutch and clutching teeth.

1. Inspect the Rail C Sliding Clutch yoke for wear.

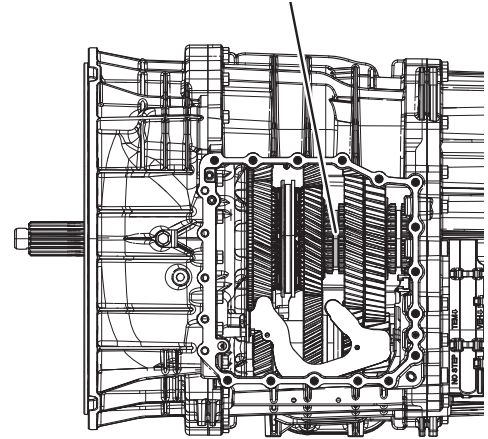

2. Shift the Rail C Sliding Clutch to the neutral position (if necessary).
3. Shift the Rail C Sliding Clutch into the Primary Drive Gear engagement position (fore).
4. Inspect the Rail C Sliding Clutch clutching teeth for wear.
5. Return the Rail C Sliding Clutch to neutral.
6. Shift the Rail C Sliding Clutch into the Secondary Driven Gear engagement position (aft).
7. Inspect the Rail C Sliding Clutch clutching teeth for wear.
8. Return the Rail C Sliding Clutch to neutral.
 - If the Rail C Sliding Clutch shifts into all three positions and no clutching teeth wear is present, contact Eaton Cummins Automated Transmission Technologies for further diagnostic instructions. For Help Line phone numbers, go to "Contact Information" on page 4
 - If the Rail C Sliding Clutch does not shift into all three positions or clutching teeth wear is present, reference Primary Drive Gear Replacement procedure for replacing the Primary Drive Gear and Rail C Sliding Clutch, and Secondary Driven Gear. Go to Step V.

Procedure B

STEP A

Purpose: Verify mechanical condition of the Primary and Secondary Drive Gears.

1. Inspect the Secondary Drive Gear for excessive fore and aft movement.

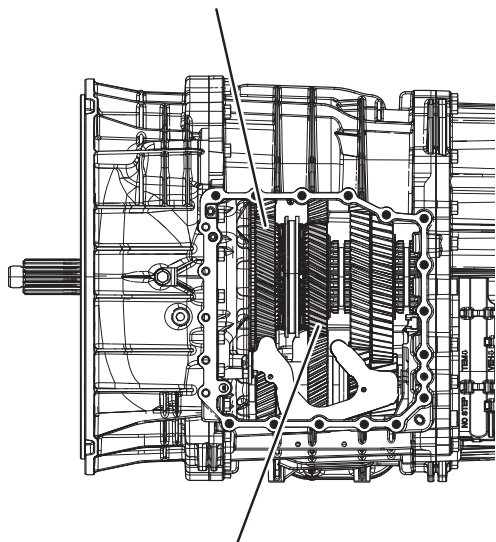

2. Inspect the Primary Drive Gear for excessive fore and aft movement.
 - If excessive gear movement is evident, inspect for cause of excessive gear movement and repair. Go to Step V.
 - If no excessive gear movement is evident, go to Procedure B, Step B.

Procedure B

STEP B

Purpose: Verify mechanical condition of the Rail B Synchronizer and clutching teeth.

1. Inspect the Rail B Synchronizer Sliding Sleeve yoke slot for wear.

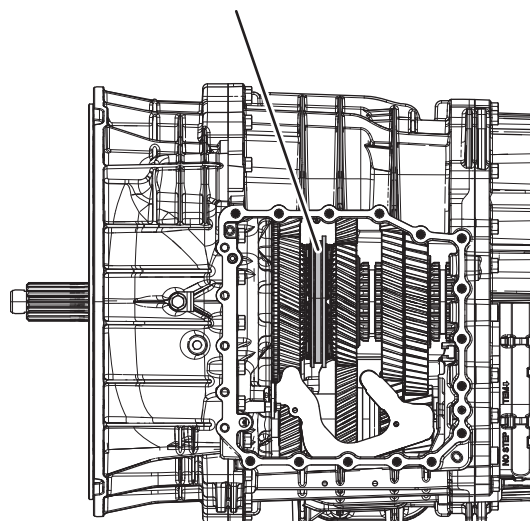

2. Install the Rail B Synchronizer Engagement Tool (RR1088TR).

Note: Reference Appendix, Manually Actuate Rail B Procedure.
3. Shift Rail B Synchronizer Sliding Sleeve into neutral (if necessary).
4. Shift the Rail B Synchronizer Sliding Sleeve into the Secondary Drive Gear engagement position (fore).
5. Inspect the Primary Drive Gear and synchronizer ring clutching teeth for wear.
6. Return the Rail B Synchronizer Sliding Sleeve to neutral.
7. Shift the Rail B Synchronizer Sliding Sleeve into the Primary Drive Gear engagement position (aft).
8. Inspect the Secondary Drive Gear and synchronizer ring clutching teeth for wear.

9. Return the Rail B Synchronizer Sliding Sleeve to neutral.
 - If the Rail B Synchronizer Sliding Sleeve shifts into all three positions and no clutching teeth wear is present, contact Eaton Cummins Automated Transmission Technologies for further diagnostic instructions. For Help Line phone numbers, go to “Contact Information” on page 4.
 - If the Rail B Synchronizer Sliding Sleeve does not shift into all three positions or clutching teeth wear is present, reference the Primary Drive Gear Replacement procedure for replacement of the Primary Drive Gear. Replace the Rail B Synchronizer Assembly and the Secondary Drive Gear. Go to Step V.

Procedure C

STEP A

Purpose: Verify mechanical condition of the Primary Drive Gear and Secondary Driven Gear.

1. Inspect the Primary Drive Gear for excessive fore and aft movement.

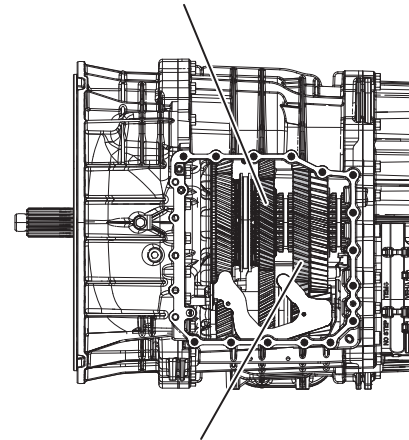

2. Inspect the Secondary Driven Gear for excessive for and aft movement.
 - If excessive gear movement is evident, inspect for cause of excessive gear movement and repair. Go to Step V.
 - If no excessive gear movement is evident, go to Procedure C, Step B.

Procedure C

STEP B

Purpose: Verify mechanical condition of the Rail C Sliding Clutch and clutching teeth.

1. Inspect the Rail C Sliding Clutch yoke slot for wear.

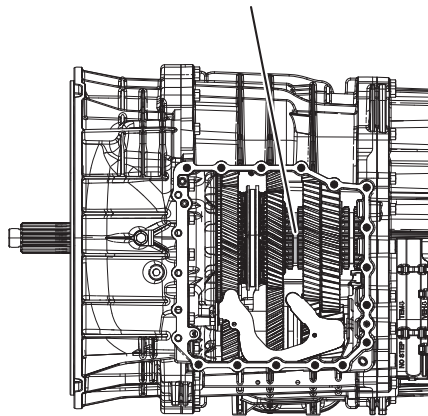

2. Shift the Rail C Sliding Clutch to the neutral position (if necessary).
3. Shift the Rail C Sliding Clutch into the Primary Drive Gear engagement position (fore).
4. Inspect the Rail C Sliding Clutch clutching teeth for wear.
5. Return the Rail C Sliding Clutch to neutral.
6. Shift the Rail C Sliding Clutch into the Secondary Driven Gear engagement position (aft).
7. Inspect the Rail C Sliding Clutch clutching teeth for wear.
8. Return the Rail C Sliding Clutch to neutral.
 - If the Rail C Sliding Clutch shifts into all three positions and no clutching teeth wear is present, contact Eaton Cummins Automated Transmission Technologies for further diagnostic instructions. For Help Line phone numbers, go to "Contact Information" on page 4.
 - If the Rail C Sliding Clutch does not shift into all three positions or clutching teeth wear is present, refer to the Primary Drive Gear Replacement procedure for replacing the Primary Drive Gear and Rail C Sliding Clutch, and Secondary Driven Gear. Go to Step V.

Procedure D

STEP A

Purpose: Verify mechanical condition of the Primary Driven Gear and Reverse Gear

1. Inspect the Primary Driven Gear for excessive fore and aft movement.

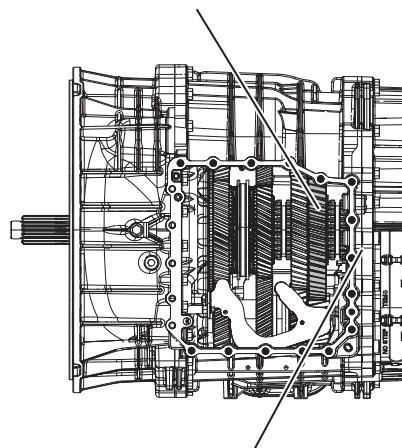

2. Inspect the Reverse Gear for excessive fore and aft movement.
 - If excessive gear movement is evident, inspect for cause of excessive gear movement and repair. Go to Step V.
 - If no excessive gear movement is evident, go to Procedure D, Step B.

Procedure D

STEP B

Purpose: Verify mechanical condition of the Rail D Sliding Clutch and clutching teeth.

1. Inspect the Rail D Sliding Clutch yoke slot for wear.

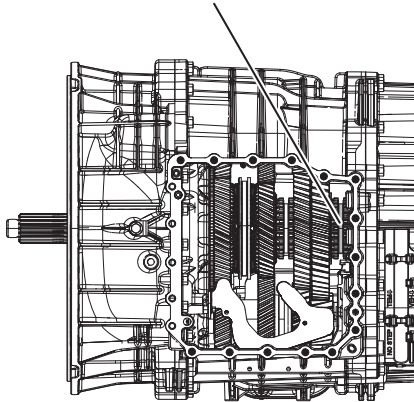

2. Shift the Rail D Sliding Clutch to the neutral position (if necessary).
3. Shift the Rail D Sliding Clutch into the Primary Driven Gear engagement position (fore).
4. Inspect the Rail D Sliding Clutch clutching teeth for wear.
5. Return the Rail D Sliding Clutch to neutral.
6. Shift the Rail D Sliding Clutch into the Reverse Gear engagement position (aft).
7. Inspect the Rail D Sliding Clutch clutching teeth for wear.
8. Return the Rail D Sliding Clutch to neutral.
 - If the Rail D Sliding Clutch shifts into all three positions and no clutching teeth wear is present, contact Eaton Cummins Automated Transmission Technologies for further diagnostic instructions. For Help Line phone numbers, go to “Contact Information” on page 4.
 - If the Rail D Sliding Clutch does not shift into all three positions or clutching teeth wear is present, replace the Rail D Sliding Clutch, Primary Driven Gear and Reverse Gear. Go to Step V.

STEP V

1. Key off.
2. Reconnect all connectors and verify that all components are properly installed.
3. Key on with engine off.
4. Connect ServiceRanger.
5. Go to “Fault Codes”.
6. Select “Clear All Faults”.
7. Operate vehicle and attempt to reset the fault code or duplicate the previous complaint.
8. Check for fault codes using ServiceRanger.
 - If no fault codes sets and the vehicle operates properly, test complete.
 - If Fault Code 617, 740, 760, 775 sets Active during operation, contact Eaton Cummins Automated Transmission Technologies for further diagnostic instructions. For Help Line phone numbers, go to “Contact Information” on page 4.
 - If a fault code other than 617, 740, 760, 775 sets Active, go to Endurant HD Troubleshooting Guide and troubleshoot per the Fault Code Isolation Procedure Index.

Warranty Information

1. Reference the relevant warranty information provided in service bulletin [TAIB-0994](#).

Release Bearing and Clutch Release Yoke

Special Instructions

None

Special Tools

None

Component Identification

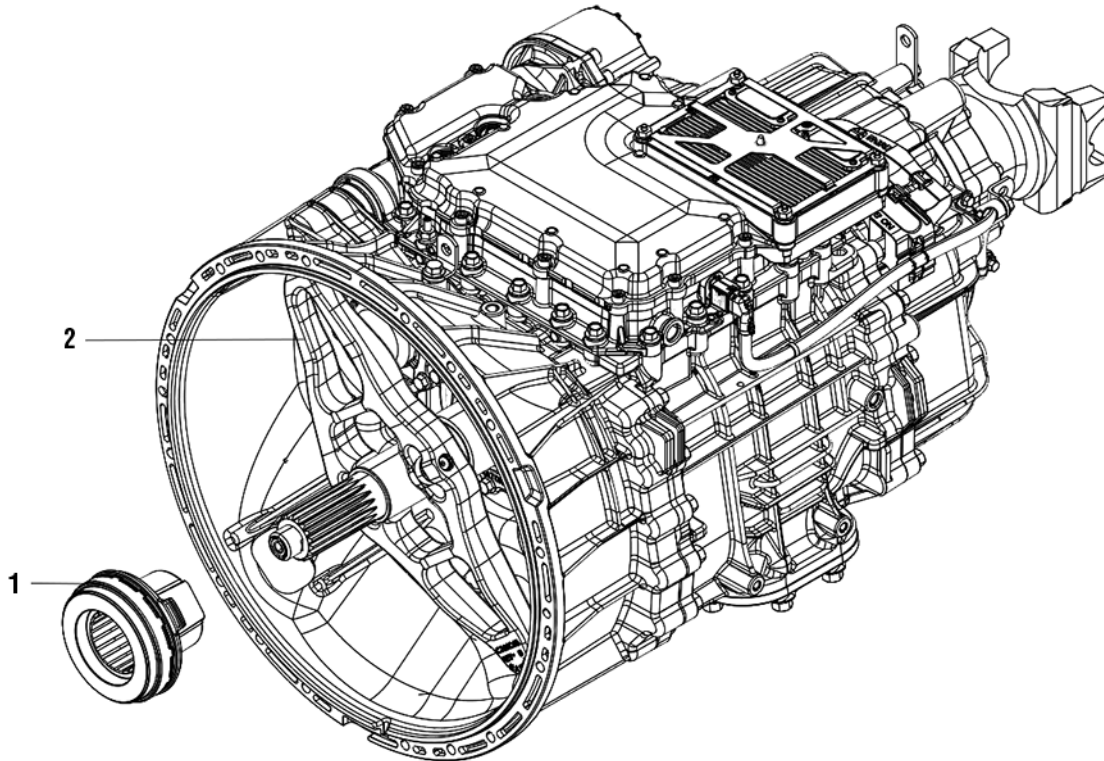

- 1. Release Bearing
- 2. Clutch Release Yoke

Manually Vent Linear Clutch Actuator (LCA)

1. Key off.
2. Set vehicle parking brake and chock wheels.

! **WARNING:** Apply vehicle parking brake and follow vehicle manufacture parking instructions. Failure to follow these instructions could cause unintended vehicle movement and may result in major vehicle component damage, severe injury or death.

3. Loosen the 4 Linear Clutch Actuator (LCA) cap screws 1-2 turns each with a T45 Torx.

Note: Residual air pressure in the LCA cylinder exhausts between the LCA and Mechatronic Transmission Module (MTM) housing when the cap screws are loosened.

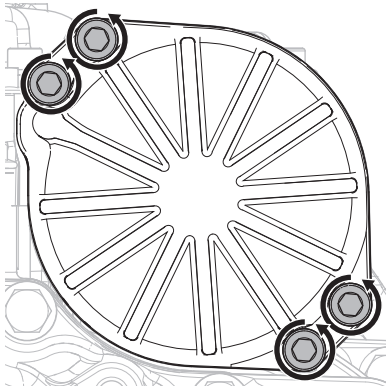

4. Tighten the 4 LCA to MTM T45 cap screws and torque to 23-27 Nm (17-21 lb-ft).

Drain Oil

1. Locate the Oil Drain Plug on the back of the rear housing.
2. Place a suitable container under the Oil Drain Plug.

Note: If reusing oil, use a clean container free of contamination and debris.

3. Remove the Oil Drain Plug with a 6 mm hex key and drain the oil.

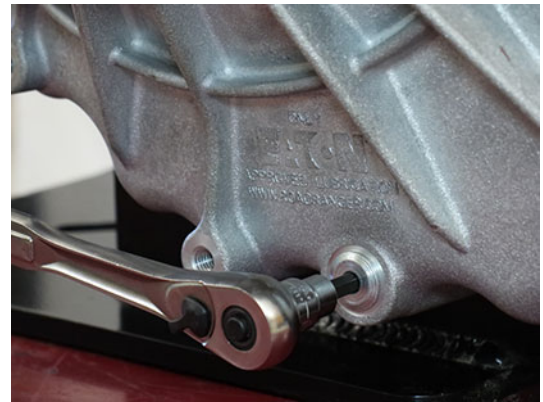

4. If PTO-equipped, remove PTO and drain the oil.
5. Inspect Oil Drain Plug and O-ring for damage. If damaged, replace the Oil Drain Plug; O-ring is serviced with plug.
6. Install the Oil Drain Plug (6 mm) and torque to 24.5-29.5 Nm (18-22 lb-ft).

NOTICE: Do not over-torque drain plug or transmission damage may occur.

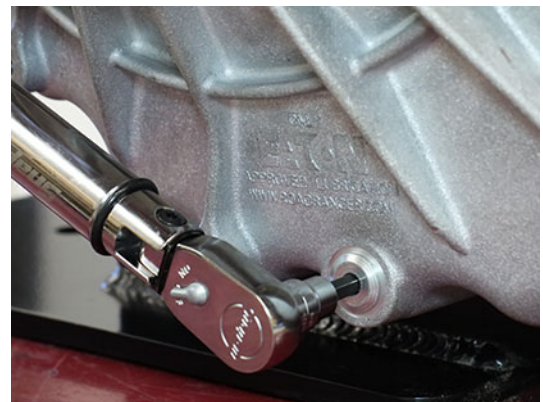

Remove the Transmission

1. Disconnect negative battery cable.
2. Refer to OEM guidelines for transmission removal.

Remove the Release Bearing and Clutch Release Yoke

1. Remove the Release Bearing by sliding the bearing off the input shaft.



2. Pull to free the lower Clutch Release Yoke socket from the lower pivot on the clutch housing.

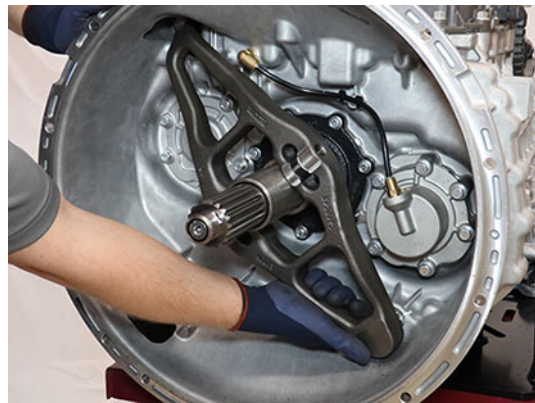

3. Pull to free the upper Clutch Release Yoke socket from the Linear Clutch Actuator (LCA) rod end.



4. Inspect the plastic socket inserts in the Clutch Release Yoke to verify none of the fingers are missing or damaged.

Note: If the plastic insert is damaged, replace the Clutch Release Yoke assembly.



Remove the Linear Clutch Actuator (LCA)

1. Loosen the 4 LCA cap screws 1-2 turns each with a T45 Torx.

NOTICE: Ensure key is off, 20-Way TCM Vehicle and Body Harness Connectors are disconnected, and 5 minutes has passed prior to LCA removal.

Note: Residual air pressure in the LCA cylinder exhausts between the LCA and MTM housing when the cap screws are loosened.



2. Remove the 4 LCA cap screws
3. Remove the LCA from the MTM.

Note: LCA piston rod end is seated in the release yoke socket; pull to release rod end from socket.



- Inspect the plastic socket insert in the release yoke through the LCA opening using a flashlight to verify none of the fingers are missing or damaged.

Note: If the plastic insert is damaged, replace the release yoke assembly.

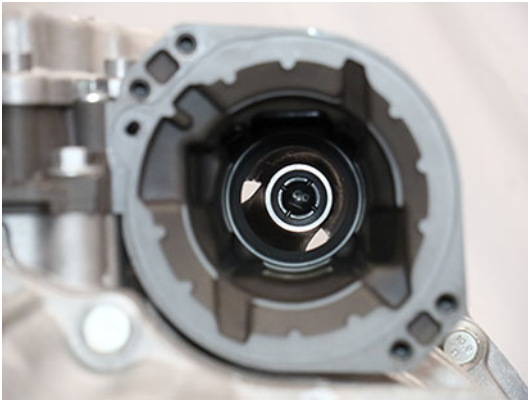

Reset and Install Linear Clutch Actuator (LCA)

- Inspect LCA to determine next steps, reference images below:
 - If LCA is locked in the reset position, go to Install Linear Clutch Actuator (LCA).
 - If LCA is not locked in the reset position, go to Step 2.

Locked in Reset Position

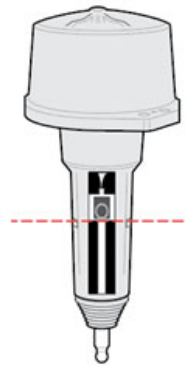

Not Locked in Reset Position

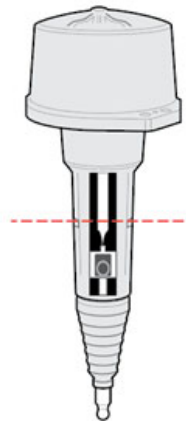

- Place LCA push rod on a clean, flat surface. Tightly grasp LCA housing with both hands and push down on push rod to lock LCA into the reset position.



CAUTION: A large amount of force is required to lock the LCA into the reset position. Failure to tightly grasp the LCA housing with both hands while pushing down on push rod may cause unintended movement resulting in personal injury and/or component damage.



3. Inspect LCA to determine next steps, reference images below:

- If LCA remains locked in the reset position, go to Step 4.
- If LCA does not remain locked in the reset position, go to Step 2, repeat reset procedure.

Note: If LCA cannot be locked into the reset position, replace LCA.



CAUTION: Do not drop LCA. Dropping LCA may cause the LCA to unlock resulting in personal injury and/or component damage.

Locked in Reset Position

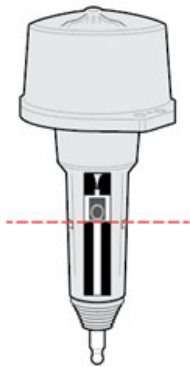

Not Locked in Reset Position

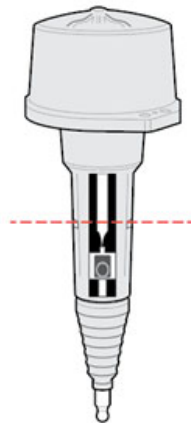

4. Clean all sealing surfaces on the MTM and LCA with a lint free cloth.

NOTICE: Do not use abrasive scrapers or powered tools to clean sealing surfaces or sealing surfaces may be damaged and leak.

5. Insert the LCA into the MTM.



6. Install 4 LCA T45 cap screws and torque to 23-28 Nm (17-21 lb-ft) in a criss-cross pattern.

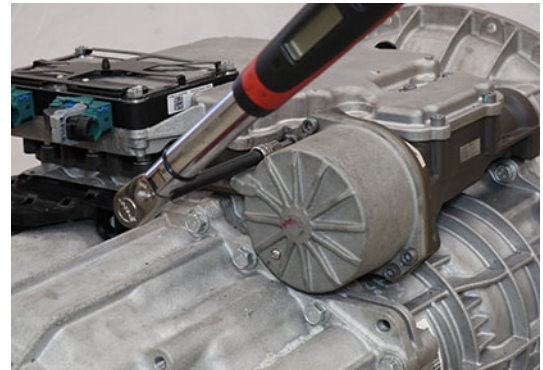

Install the Release Bearing and Clutch Release Yoke

1. Install the upper Release Yoke socket over the rod end of the Linear Clutch Actuator (LCA) and press until attached.



2. Install the lower Release Yoke socket over the lower pivot on the clutch housing and press until attached.

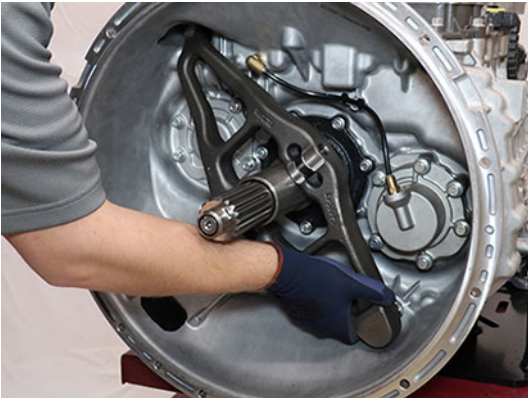

3. Slide the Release Bearing over the input shaft and into the Release Yoke.



Install the Transmission

1. Refer to OEM guidelines for transmission installation.
2. Connect negative battery cable.

Fill Oil

Note: Perform the transmission fill procedure with transmission installed in vehicle to ensure proper transmission angle.

1. Remove the Oil Fill Plug with a 6 mm hex key.

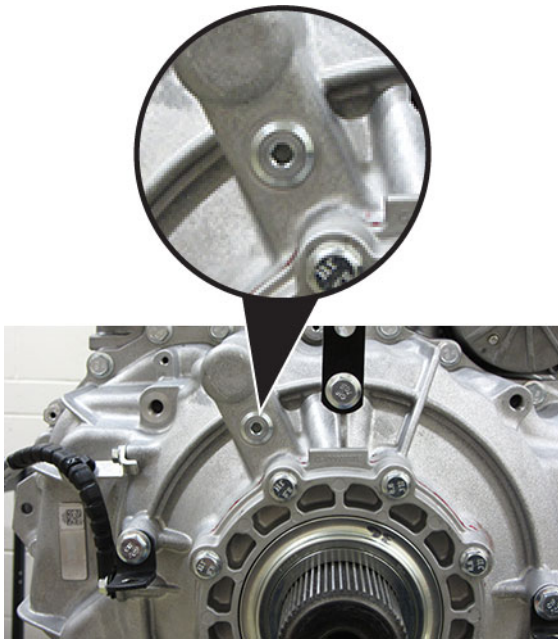

2. Place a suitable container under the Oil Check Plug and remove the Oil Check Plug with a 6 mm hex key.



3. Fill the transmission with PS-386 lube until a small amount of oil runs out of the Oil Check Plug hole.

Note: Fill capacity is approximately 7.5-8.5 liters (16-18 pints) depending on the transmission angle.

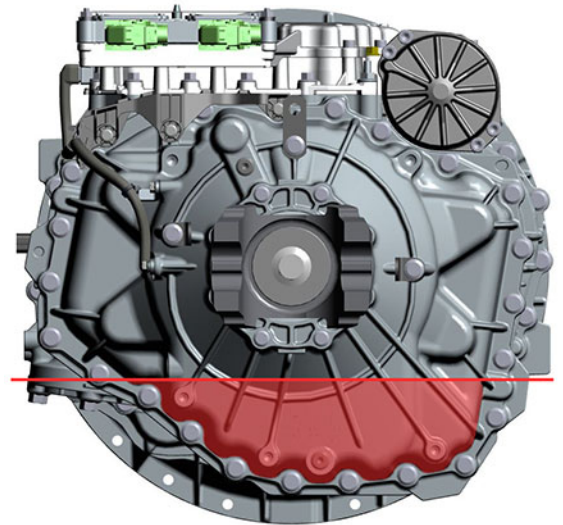
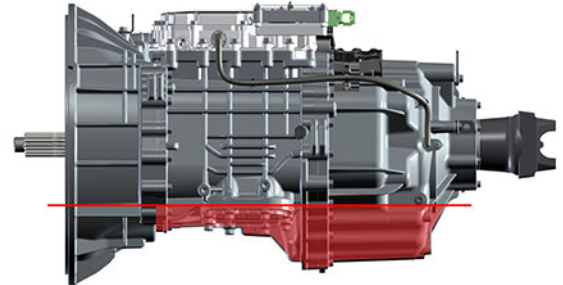

4. Inspect Oil Check Plug and O-ring for damage. If damaged, replace the Oil Check Plug; O-ring is serviced with plug.

5. Install the Oil Check Plug (6 mm) and torque to 24.5-29.5 Nm (18-22 lb-ft).

NOTICE: Do not over-torque the Oil Fill Plug or transmission damage may occur.



6. Inspect Oil Fill Plug and O-ring for damage. If damaged, replace the Oil Fill Plug; O-ring is serviced with plug.
7. Install the Oil Fill Plug (6 mm) and torque to 24.5-29.5 Nm (18-22 lb-ft).

NOTICE: Do not over-torque the Oil Fill Plug or transmission damage may occur.

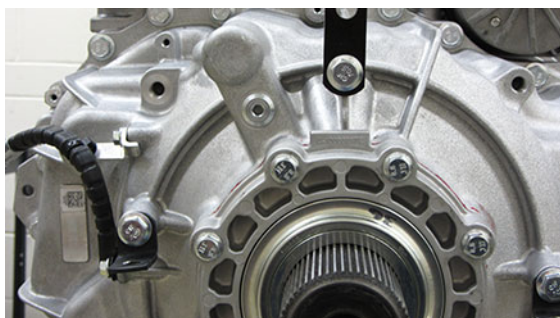

Clutch and Rail Calibration

To ensure proper operation, the TCM, clutch, MTM and transmission require a Clutch and Rail Calibration. Calibrations are automatically initiated when:

- LCA is in the reset position
- Transmission in "N" (Neutral)
- Key on engine running
- Vehicle air system pressure at operating range

NOTICE: Do not use service tool to initiate calibrations. Allow calibrations to automatically initiate.

Note: Vehicle display may indicate a flashing "CC" and "F" in gear display.

1. Set vehicle parking brake and chock wheels.
2. Ensure the driveline is connected between the transmission and axle.

Note: Clutch and Rail Calibrations cannot complete if the transmission output shaft is allowed to rotate.
3. Key on with engine running.
4. Allow vehicle air pressure to build to governor cut-off.

Note: Clutch and Rail Calibrations automatically initiate when vehicle air pressure reaches approximately 100 psi.
5. Ensure "N" (Neutral) is selected and engine is running. Wait approximately 2 minutes for calibrations to complete.

NOTICE: If process is interrupted, key off, wait 1 minute and go to Step 2.

 - If vehicle display indicates a solid "N: (Neutral) in gear display, calibrations are complete. Key off, go to Step 6.
 - If vehicle display continues to indicate a flashing "CC" and/or "F" in gear display or service transmission message, go to Step 5.
6. Key off and wait 1 minute.
7. Key on with engine off.
8. Connect ServiceRanger.

9. Go to “Fault Codes”.
 - If an Active transmission fault code is set, go to Endurant HD Troubleshooting Guide TRTS0950 **Diagnostic Procedure**.
 - If no Active transmission fault codes are set, select “Clear Eaton Faults” and follow on-screen prompts. Go to Step 9.
10. Disconnect ServiceRanger.
11. Key off.
12. Inspect transmission for a PTO.
 - If not PTO-equipped, process complete.
 - If PTO-equipped, start the engine and run for 1 to 2 minutes to fill the PTO with oil, key off and repeat the Fill Oil Procedure.



CAUTION: Failure to repeat the Fill Oil service procedure to verify proper transmission oil level when equipped with a PTO may result in low transmission oil and component damage.

Upper Countershaft Cover

Special Instructions

None

Special Tools

None

Component Identification

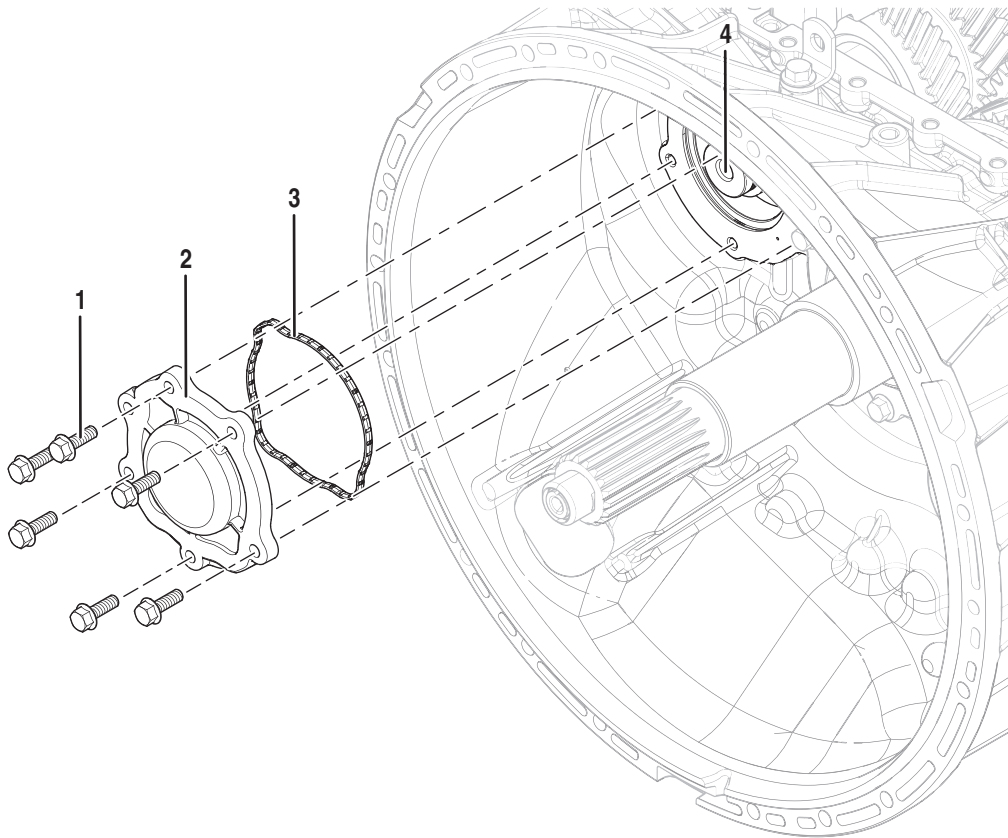

1. Upper Countershaft Cover Cap Screws (x6) - 13 mm
2. Upper Countershaft Cover
3. Seal
4. Upper Countershaft

Manually Vent Linear Clutch Actuator (LCA)

1. Key off.
2. Set vehicle parking brake and chock wheels.

! **WARNING:** Apply vehicle parking brake and follow vehicle manufacture parking instructions. Failure to follow these instructions could cause unintended vehicle movement and may result in major vehicle component damage, severe injury or death.

3. Loosen the 4 Linear Clutch Actuator (LCA) cap screws 1-2 turns each with a T45 Torx.

Note: Residual air pressure in the LCA cylinder exhausts between the LCA and Mechatronic Transmission Module (MTM) housing when the cap screws are loosened.

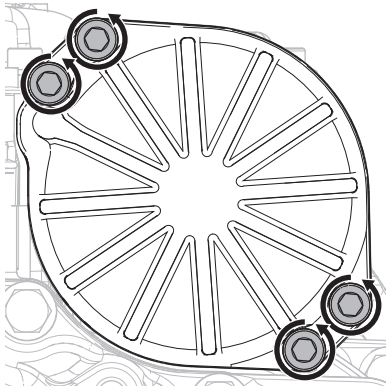

4. Tighten the 4 LCA to MTM T45 cap screws and torque to 23-27 Nm (17-21 lb-ft).

Drain Oil

1. Locate the Oil Drain Plug on the back of the rear housing.
2. Place a suitable container under the Oil Drain Plug.

Note: If reusing oil, use a clean container free of contamination and debris.

3. Remove the Oil Drain Plug with a 6 mm hex key and drain the oil.

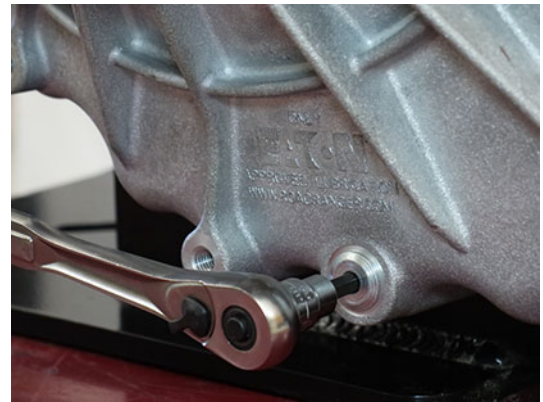

4. If PTO-equipped, remove PTO and drain the oil.
5. Inspect Oil Drain Plug and O-ring for damage. If damaged, replace the Oil Drain Plug; O-ring is serviced with plug.
6. Install the Oil Drain Plug (6 mm) and torque to 24.5-29.5 Nm (18-22 lb-ft).

NOTICE: Do not over-torque drain plug or transmission damage may occur.



Remove the Transmission

1. Disconnect negative battery cable.
2. Refer to OEM guidelines for transmission removal.

Remove the Release Bearing and Clutch Release Yoke

1. Remove the Release Bearing by sliding the bearing off the input shaft.



2. Pull to free the lower Clutch Release Yoke socket from the lower pivot on the clutch housing.

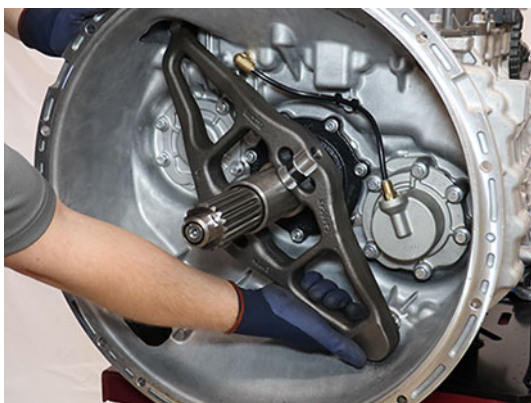

3. Pull to free the upper Clutch Release Yoke socket from the Linear Clutch Actuator (LCA) rod end.



4. Inspect the plastic socket inserts in the Clutch Release Yoke to verify none of the fingers are missing or damaged.

Note: If the plastic insert is damaged, replace the Clutch Release Yoke assembly.



Remove the Upper Countershaft Cover

1. Remove the 6 Upper Countershaft Cover 13 mm cap screws and remove cover.

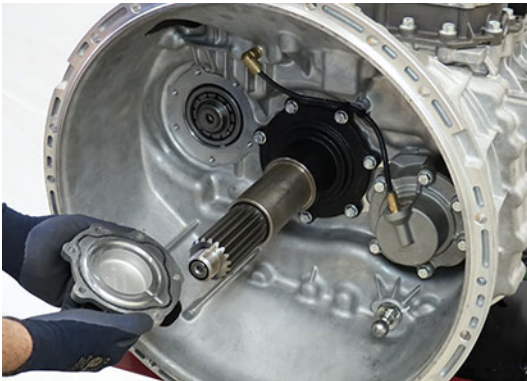

2. Remove the Upper Countershaft Cover Seal.

NOTICE: A new Upper Countershaft Cover Seal is required when reinstalling or an oil leak may occur.

Note: Reference “RRMT0027 - Clutch Housing Front Cover Kit” on page 586 for new Upper Countershaft Cover part number, additional O-ring part number, and installation instructions.



Install the Upper Countershaft Cover

1. Clean the sealing surfaces on the clutch housing and the Upper Countershaft Cover.

Note: A new Upper Countershaft Cover Seal is required when reinstalling or an oil leak may occur. Reference “RRMT0027 - Clutch Housing Front Cover Kit” on page 586 for new Upper Countershaft Cover part number, additional O-ring part number, and installation instructions.

2. Insert the Upper Countershaft Cover Seal into the groove until fully seated.



3. Install the Upper Countershaft Cover to the Clutch Housing.

4. Install the six 13 mm cap screws and torque to 21-25 Nm (16-19 lb-ft) in a criss-cross pattern.



Remove the Linear Clutch Actuator (LCA)

1. Loosen the 4 LCA cap screws 1-2 turns each with a T45 Torx.

NOTICE: Ensure key is off, 20-Way TCM Vehicle and Body Harness Connectors are disconnected, and 5 minutes has passed prior to LCA removal.

Note: Residual air pressure in the LCA cylinder exhausts between the LCA and MTM housing when the cap screws are loosened.



2. Remove the 4 LCA cap screws
3. Remove the LCA from the MTM.

Note: LCA piston rod end is seated in the release yoke socket; pull to release rod end from socket.



- Inspect the plastic socket insert in the release yoke through the LCA opening using a flashlight to verify none of the fingers are missing or damaged.

Note: If the plastic insert is damaged, replace the release yoke assembly.

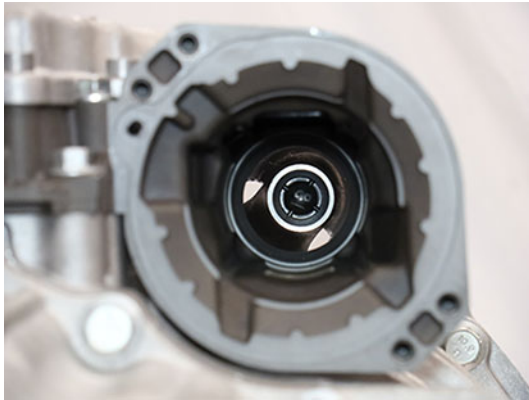

Reset and Install Linear Clutch Actuator (LCA)

- Inspect LCA to determine next steps, reference images below:
 - If LCA is locked in the reset position, go to Install Linear Clutch Actuator (LCA).
 - If LCA is not locked in the reset position, go to Step 2.

Locked in Reset Position

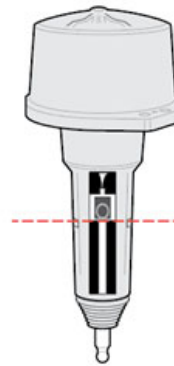

Not Locked in Reset Position

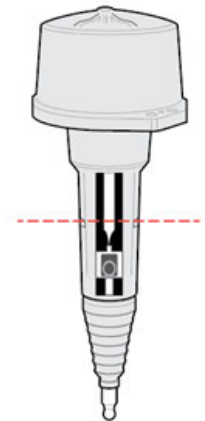

- Place LCA push rod on a clean, flat surface. Tightly grasp LCA housing with both hands and push down on push rod to lock LCA into the reset position.



CAUTION: A large amount of force is required to lock the LCA into the reset position. Failure to tightly grasp the LCA housing with both hands while pushing down on push rod may cause unintended movement resulting in personal injury and/or component damage.



3. Inspect LCA to determine next steps, reference images below:

- If LCA remains locked in the reset position, go to Step 4.
- If LCA does not remain locked in the reset position, go to Step 2, repeat reset procedure.

Note: If LCA cannot be locked into the reset position, replace LCA.



CAUTION: Do not drop LCA. Dropping LCA may cause the LCA to unlock resulting in personal injury and/or component damage.

Locked in Reset Position

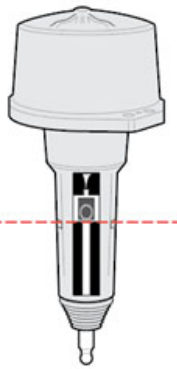

Not Locked in Reset Position

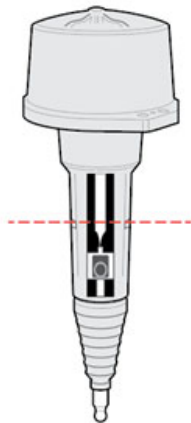

4. Clean all sealing surfaces on the MTM and LCA with a lint free cloth.

NOTICE: Do not use abrasive scrapers or powered tools to clean sealing surfaces or sealing surfaces may be damaged and leak.

5. Insert the LCA into the MTM.



6. Install 4 LCA T45 cap screws and torque to 23-28 Nm (17-21 lb-ft) in a criss-cross pattern.

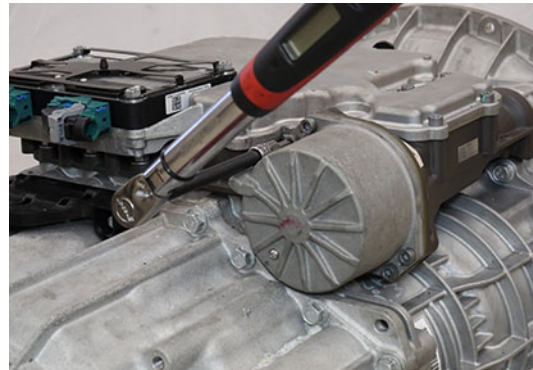

Install the Release Bearing and Clutch Release Yoke

1. Install the upper Release Yoke socket over the rod end of the Linear Clutch Actuator (LCA) and press until attached.



2. Install the lower Release Yoke socket over the lower pivot on the clutch housing and press until attached.

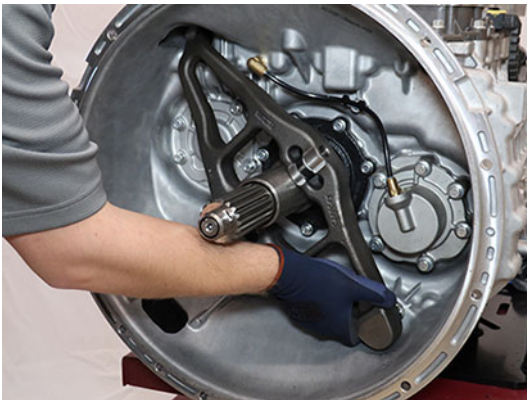

3. Slide the Release Bearing over the input shaft and into the Release Yoke.



Install the Transmission

1. Refer to OEM guidelines for transmission installation.
2. Connect negative battery cable.

Fill Oil

Note: Perform the transmission fill procedure with transmission installed in vehicle to ensure proper transmission angle.

1. Remove the Oil Fill Plug with a 6 mm hex key.

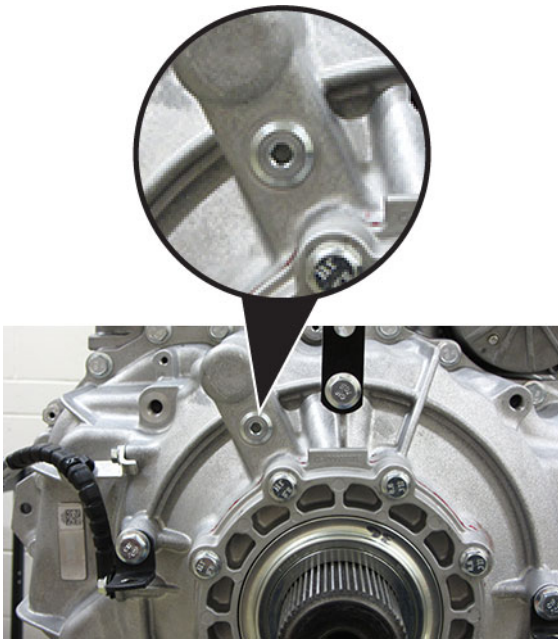

2. Place a suitable container under the Oil Check Plug and remove the Oil Check Plug with a 6 mm hex key.



3. Fill the transmission with PS-386 lube until a small amount of oil runs out of the Oil Check Plug hole.

Note: Fill capacity is approximately 7.5-8.5 liters (16-18 pints) depending on the transmission angle.

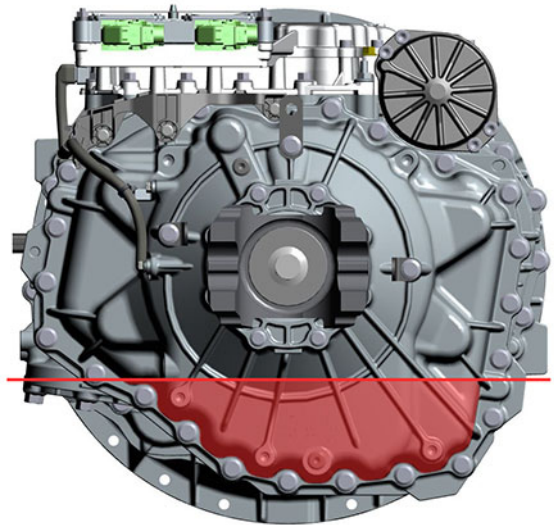
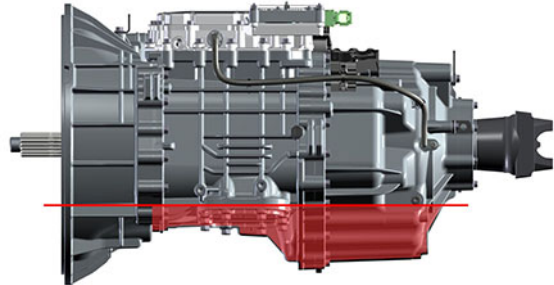

4. Inspect Oil Check Plug and O-ring for damage. If damaged, replace the Oil Check Plug; O-ring is serviced with plug.

5. Install the Oil Check Plug (6 mm) and torque to 24.5-29.5 Nm (18-22 lb-ft).

NOTICE: Do not over-torque the Oil Fill Plug or transmission damage may occur.



6. Inspect Oil Fill Plug and O-ring for damage. If damaged, replace the Oil Fill Plug; O-ring is serviced with plug.
7. Install the Oil Fill Plug (6 mm) and torque to 24.5-29.5 Nm (18-22 lb-ft).

NOTICE: Do not over-torque the Oil Fill Plug or transmission damage may occur.

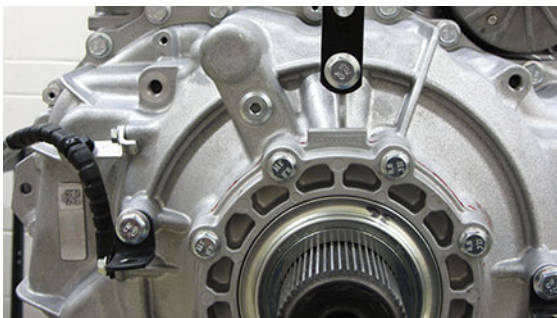

Clutch and Rail Calibration

To ensure proper operation, the TCM, clutch, MTM and transmission require a Clutch and Rail Calibration. Calibrations are automatically initiated when:

- LCA is in the reset position
- Transmission in “N” (Neutral)
- Key on engine running
- Vehicle air system pressure at operating range

NOTICE: Do not use service tool to initiate calibrations. Allow calibrations to automatically initiate.

Note: Vehicle display may indicate a flashing “CC” and “F” in gear display.

1. Set vehicle parking brake and chock wheels.
2. Ensure the driveline is connected between the transmission and axle.

Note: Clutch and Rail Calibrations cannot complete if the transmission output shaft is allowed to rotate.
3. Key on with engine running.
4. Allow vehicle air pressure to build to governor cut-off.

Note: Clutch and Rail Calibrations automatically initiate when vehicle air pressure reaches approximately 100 psi.
5. Ensure “N” (Neutral) is selected and engine is running. Wait approximately 2 minutes for calibrations to complete.

NOTICE: If process is interrupted, key off, wait 1 minute and go to Step 2.

 - If vehicle display indicates a solid “N: (Neutral) in gear display, calibrations are complete. Key off, go to Step 6.
 - If vehicle display continues to indicate a flashing “CC” and/or “F” in gear display or service transmission message, go to Step 5.
6. Key off and wait 1 minute.
7. Key on with engine off.
8. Connect ServiceRanger.

9. Go to “Fault Codes”.
 - If an Active transmission fault code is set, go to Endurant HD Troubleshooting Guide TRTS0950 **Diagnostic Procedure**.
 - If no Active transmission fault codes are set, select “Clear Eaton Faults” and follow on-screen prompts. Go to Step 9.
10. Disconnect ServiceRanger.
11. Key off.
12. Inspect transmission for a PTO.
 - If not PTO-equipped, process complete.
 - If PTO-equipped, start the engine and run for 1 to 2 minutes to fill the PTO with oil, key off and repeat the Fill Oil Procedure.



CAUTION: Failure to repeat the Fill Oil service procedure to verify proper transmission oil level when equipped with a PTO may result in low transmission oil and component damage.

Input Shaft Cover

Special Instructions

None

Special Tools

None

Component Identification

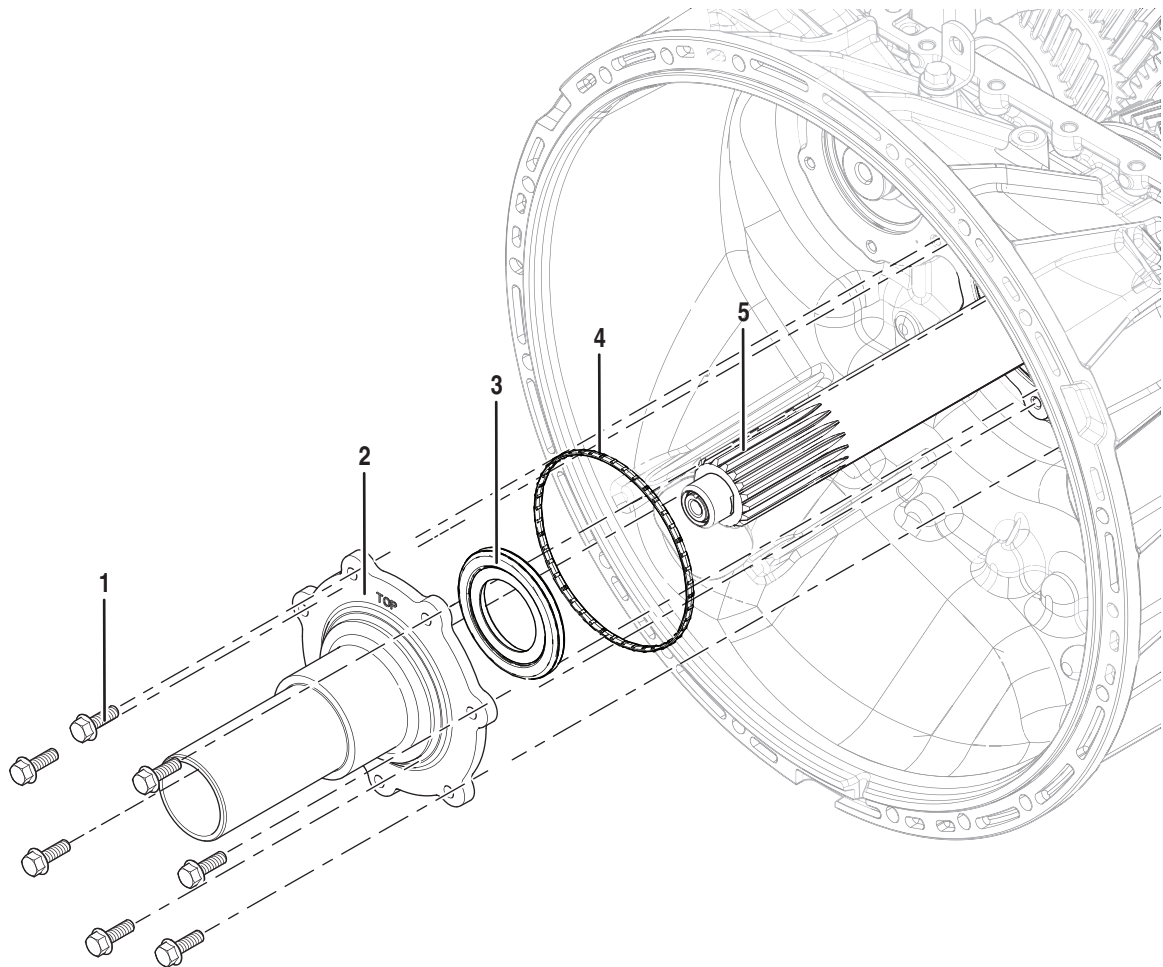

1. Input Shaft Cover Cap Screws (x7) - 13 mm
2. Input Shaft Cover
3. Seal
4. Seal
5. Input Shaft

Manually Vent Linear Clutch Actuator (LCA)

1. Key off.
2. Set vehicle parking brake and chock wheels.

! **WARNING:** Apply vehicle parking brake and follow vehicle manufacture parking instructions. Failure to follow these instructions could cause unintended vehicle movement and may result in major vehicle component damage, severe injury or death.

3. Loosen the 4 Linear Clutch Actuator (LCA) cap screws 1-2 turns each with a T45 Torx.

Note: Residual air pressure in the LCA cylinder exhausts between the LCA and Mechatronic Transmission Module (MTM) housing when the cap screws are loosened.

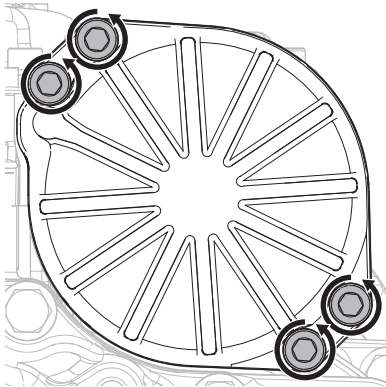

4. Tighten the 4 LCA to MTM T45 cap screws and torque to 23-27 Nm (17-21 lb-ft).

Drain Oil

1. Locate the Oil Drain Plug on the back of the rear housing.
2. Place a suitable container under the Oil Drain Plug.

Note: If reusing oil, use a clean container free of contamination and debris.

3. Remove the Oil Drain Plug with a 6 mm hex key and drain the oil.

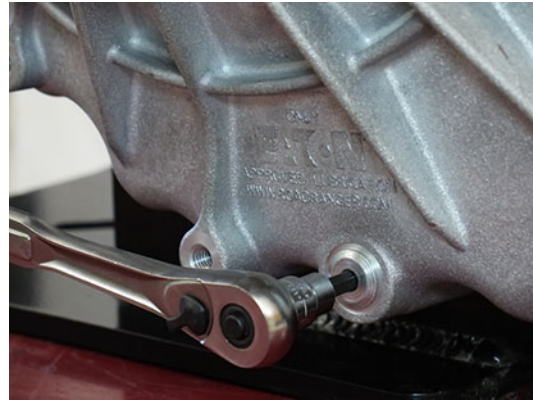

4. If PTO-equipped, remove PTO and drain the oil.
5. Inspect Oil Drain Plug and O-ring for damage. If damaged, replace the Oil Drain Plug; O-ring is serviced with plug.
6. Install the Oil Drain Plug (6 mm) and torque to 24.5-29.5 Nm (18-22 lb-ft).

NOTICE: Do not over-torque drain plug or transmission damage may occur.



Remove the Transmission

1. Disconnect negative battery cable.
2. Refer to OEM guidelines for transmission removal.

Remove the Release Bearing and Clutch Release Yoke

1. Remove the Release Bearing by sliding the bearing off the input shaft.



2. Pull to free the lower Clutch Release Yoke socket from the lower pivot on the clutch housing.



3. Pull to free the upper Clutch Release Yoke socket from the Linear Clutch Actuator (LCA) rod end.



4. Inspect the plastic socket inserts in the Clutch Release Yoke to verify none of the fingers are missing or damaged.

Note: If the plastic insert is damaged, replace the Clutch Release Yoke assembly.



Remove the Input Shaft Cover

1. Remove the 7 Input Shaft Cover 13 mm cap screws.



2. Remove the Input Shaft Cover.



Install the Input Shaft Cover

1. Clean sealing surfaces on the clutch housing and Input Shaft Cover.
2. Slide the Input Shaft Cover over the Input Shaft.

Note: Align "TOP" at 12 o'clock.



3. Install the 7 Input Shaft Cover 13 mm cap screws and torque to 21-25 Nm (16-19 lb-ft) in a criss-cross pattern.

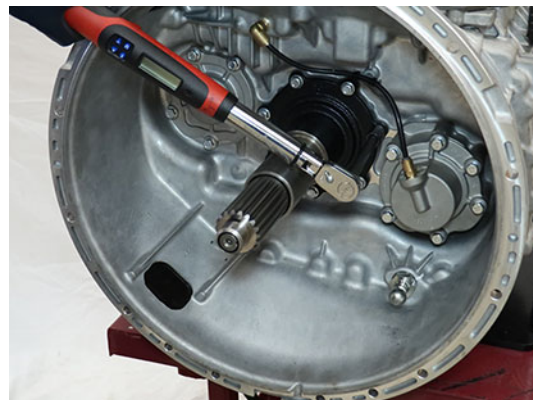

Remove the Linear Clutch Actuator (LCA)

1. Loosen the 4 LCA cap screws 1-2 turns each with a T45 Torx.

NOTICE: Ensure key is off, 20-Way TCM Vehicle and Body Harness Connectors are disconnected, and 5 minutes has passed prior to LCA removal.

Note: Residual air pressure in the LCA cylinder exhausts between the LCA and MTM housing when the cap screws are loosened.



2. Remove the 4 LCA cap screws
3. Remove the LCA from the MTM.

Note: LCA piston rod end is seated in the release yoke socket; pull to release rod end from socket.



4. Inspect the plastic socket insert in the release yoke through the LCA opening using a flashlight to verify none of the fingers are missing or damaged.

Note: If the plastic insert is damaged, replace the release yoke assembly.

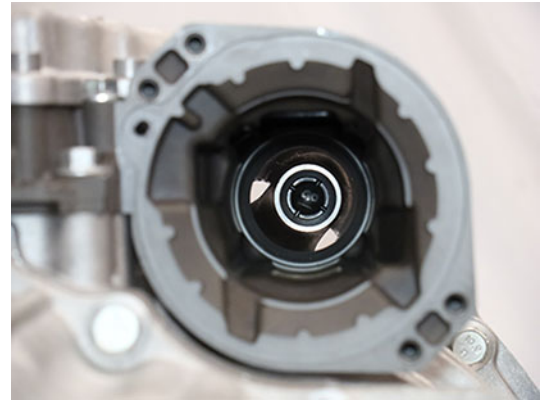

Reset and Install Linear Clutch Actuator (LCA)

1. Inspect LCA to determine next steps, reference images below:
 - If LCA is locked in the reset position, go to Install Linear Clutch Actuator (LCA).
 - If LCA is not locked in the reset position, go to Step 2.

Locked in Reset Position

Not Locked in Reset Position

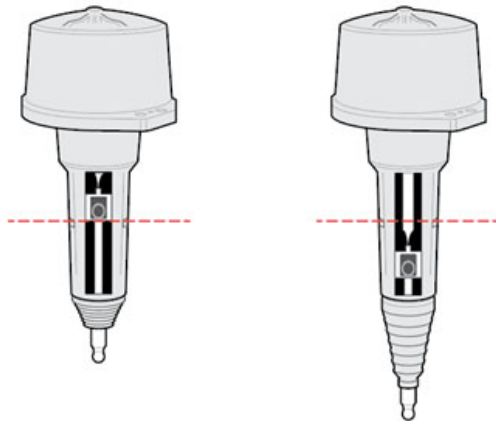

2. Place LCA push rod on a clean, flat surface. Tightly grasp LCA housing with both hands and push down on push rod to lock LCA into the reset position.



CAUTION: A large amount of force is required to lock the LCA into the reset position. Failure to tightly grasp the LCA housing with both hands while pushing down on push rod may cause unintended movement resulting in personal injury and/or component damage.

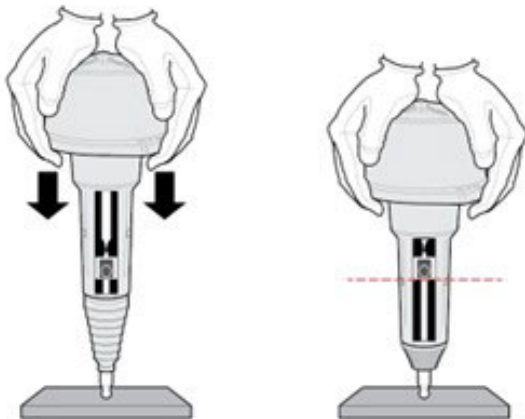

3. Inspect LCA to determine next steps, reference images below:

- If LCA remains locked in the reset position, go to Step 4.
- If LCA does not remain locked in the reset position, go to Step 2, repeat reset procedure.

Note: If LCA cannot be locked into the reset position, replace LCA.

CAUTION: Do not drop LCA. Dropping LCA may cause the LCA to unlock resulting in personal injury and/or component damage.

Locked in Reset Position

Not Locked in Reset Position

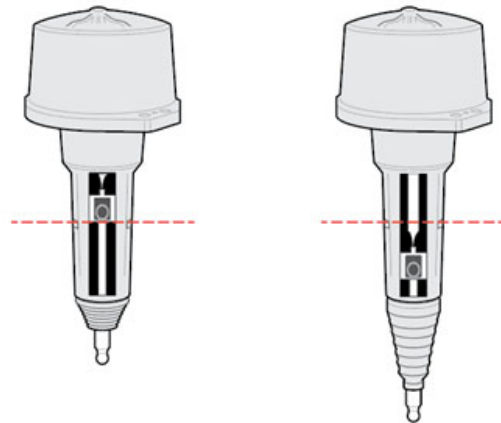

4. Clean all sealing surfaces on the MTM and LCA with a lint free cloth.

NOTICE: Do not use abrasive scrapers or powered tools to clean sealing surfaces or sealing surfaces may be damaged and leak.

5. Insert the LCA into the MTM.



6. Install 4 LCA T45 cap screws and torque to 23-28 Nm (17-21 lb-ft) in a criss-cross pattern.

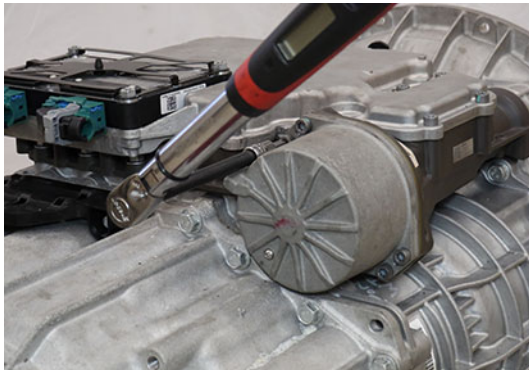

Install the Release Bearing and Clutch Release Yoke

1. Install the upper Release Yoke socket over the rod end of the Linear Clutch Actuator (LCA) and press until attached.



2. Install the lower Release Yoke socket over the lower pivot on the clutch housing and press until attached.

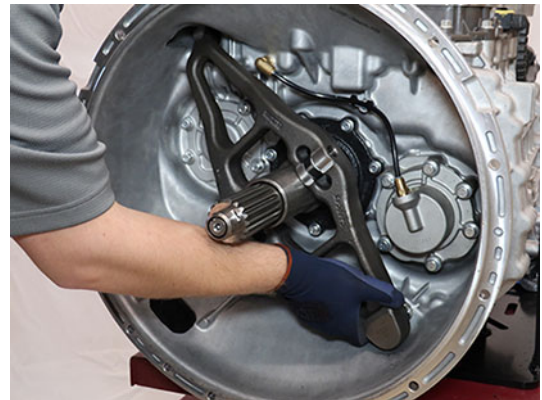

3. Slide the Release Bearing over the input shaft and into the Release Yoke.



Install the Transmission

1. Refer to OEM guidelines for transmission installation.
2. Connect negative battery cable.

Fill Oil

Note: Perform the transmission fill procedure with transmission installed in vehicle to ensure proper transmission angle.

1. Remove the Oil Fill Plug with a 6 mm hex key.

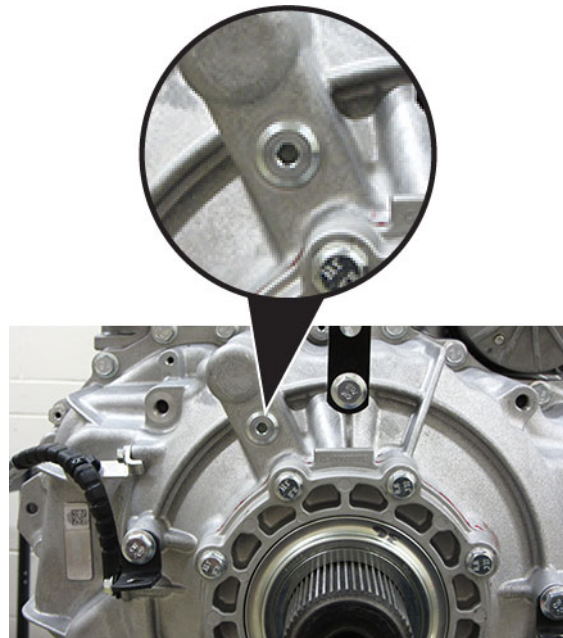

2. Place a suitable container under the Oil Check Plug and remove the Oil Check Plug with a 6 mm hex key.



3. Fill the transmission with PS-386 lube until a small amount of oil runs out of the Oil Check Plug hole.

Note: Fill capacity is approximately 7.5-8.5 liters (16-18 pints) depending on the transmission angle.

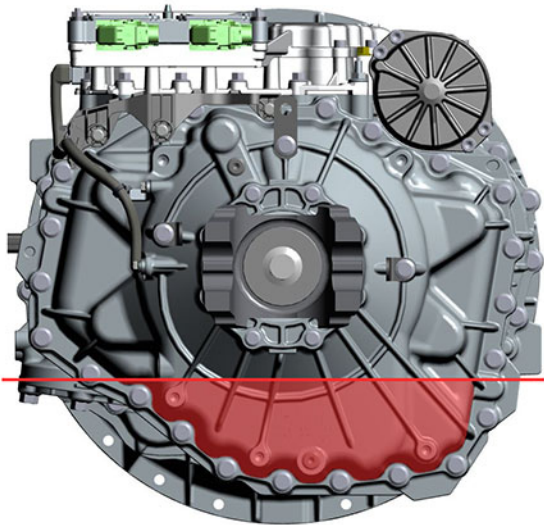
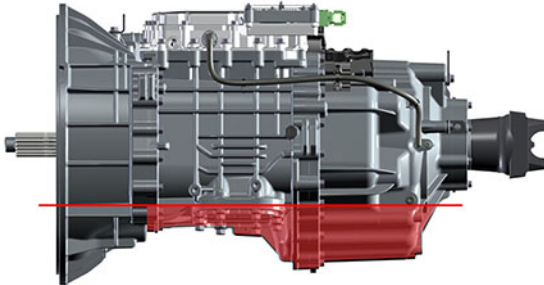

4. Inspect Oil Check Plug and O-ring for damage. If damaged, replace the Oil Check Plug; O-ring is serviced with plug.

5. Install the Oil Check Plug (6 mm) and torque to 24.5-29.5 Nm (18-22 lb-ft).

NOTICE: Do not over-torque the Oil Fill Plug or transmission damage may occur.



6. Inspect Oil Fill Plug and O-ring for damage. If damaged, replace the Oil Fill Plug; O-ring is serviced with plug.
7. Install the Oil Fill Plug (6 mm) and torque to 24.5-29.5 Nm (18-22 lb-ft).

NOTICE: Do not over-torque the Oil Fill Plug or transmission damage may occur.

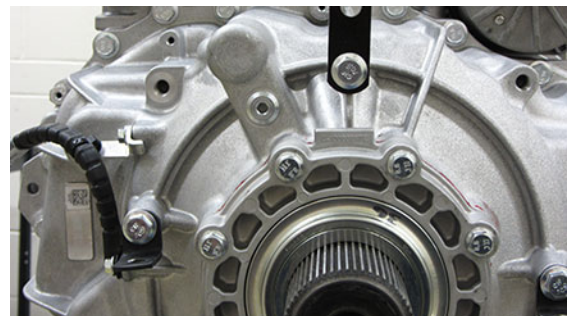

Clutch and Rail Calibration

To ensure proper operation, the TCM, clutch, MTM and transmission require a Clutch and Rail Calibration. Calibrations are automatically initiated when:

- LCA is in the reset position
- Transmission in “N” (Neutral)
- Key on engine running
- Vehicle air system pressure at operating range

NOTICE: Do not use service tool to initiate calibrations. Allow calibrations to automatically initiate.

Note: Vehicle display may indicate a flashing “CC” and “F” in gear display.

1. Set vehicle parking brake and chock wheels.
2. Ensure the driveline is connected between the transmission and axle.

Note: Clutch and Rail Calibrations cannot complete if the transmission output shaft is allowed to rotate.
3. Key on with engine running.
4. Allow vehicle air pressure to build to governor cut-off.

Note: Clutch and Rail Calibrations automatically initiate when vehicle air pressure reaches approximately 100 psi.
5. Ensure “N” (Neutral) is selected and engine is running. Wait approximately 2 minutes for calibrations to complete.

NOTICE: If process is interrupted, key off, wait 1 minute and go to Step 2.

 - If vehicle display indicates a solid “N: (Neutral) in gear display, calibrations are complete. Key off, go to Step 6.
 - If vehicle display continues to indicate a flashing “CC” and/or “F” in gear display or service transmission message, go to Step 5.
6. Key off and wait 1 minute.
7. Key on with engine off.
8. Connect ServiceRanger.



9. Go to “Fault Codes”.
 - If an Active transmission fault code is set, go to Endurant HD Troubleshooting Guide TRTS0950 **Diagnostic Procedure**.
 - If no Active transmission fault codes are set, select “Clear Eaton Faults” and follow on-screen prompts. Go to Step 9.
10. Disconnect ServiceRanger.
11. Key off.
12. Inspect transmission for a PTO.
 - If not PTO-equipped, process complete.
 - If PTO-equipped, start the engine and run for 1 to 2 minutes to fill the PTO with oil, key off and repeat the Fill Oil Procedure.

CAUTION: Failure to repeat the Fill Oil service procedure to verify proper transmission oil level when equipped with a PTO may result in low transmission oil and component damage.

Lower Countershaft Cover and Inertia Brake

Special Instructions

None

Special Tools

None

Component Identification

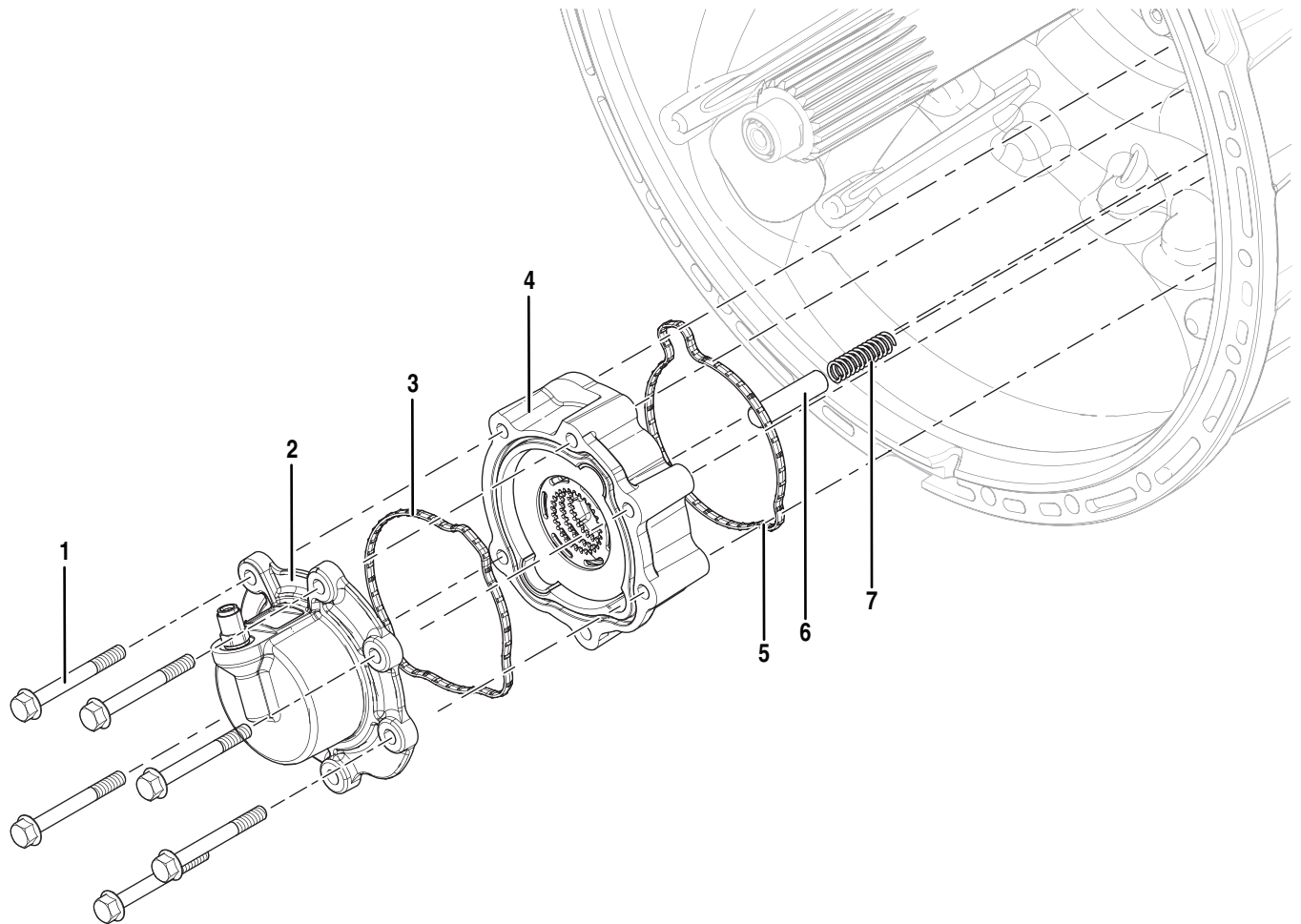

1. Inertia Brake Cover Cap Screws (x6) - 13 mm
2. Inertia Brake Cover
3. Inertia Brake Cover Seal
4. Inertia Brake Housing
5. Inertia Brake Housing Seal
6. Piston Pin
7. Return Spring

Drain Oil

1. Locate the Oil Drain Plug on the back of the rear housing.
2. Place a suitable container under the Oil Drain Plug.

Note: If reusing oil, use a clean container free of contamination and debris.

3. Remove the Oil Drain Plug with a 6 mm hex key and drain the oil.



4. If PTO-equipped, remove PTO and drain the oil.
5. Inspect Oil Drain Plug and O-ring for damage. If damaged, replace the Oil Drain Plug; O-ring is serviced with plug.
6. Install the Oil Drain Plug (6 mm) and torque to 24.5-29.5 Nm (18-22 lb-ft).

NOTICE: Do not over-torque drain plug or transmission damage may occur.



Manually Vent Linear Clutch Actuator (LCA)

1. Key off.
2. Set vehicle parking brake and chock wheels.



WARNING: Apply vehicle parking brake and follow vehicle manufacture parking instructions. Failure to follow these instructions could cause unintended vehicle movement and may result in major vehicle component damage, severe injury or death.

3. Loosen the 4 Linear Clutch Actuator (LCA) cap screws 1-2 turns each with a T45 Torx.

Note: Residual air pressure in the LCA cylinder exhausts between the LCA and Mechatronic Transmission Module (MTM) housing when the cap screws are loosened.

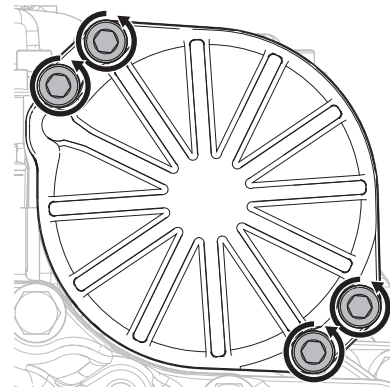

4. Tighten the 4 LCA to MTM T45 cap screws and torque to 23-27 Nm (17-21 lb-ft).

Remove the Transmission

1. Disconnect negative battery cable.
2. Refer to OEM guidelines for transmission removal.

Remove the Release Bearing and Clutch Release Yoke

1. Remove the Release Bearing by sliding the bearing off the input shaft.



2. Pull to free the lower Clutch Release Yoke socket from the lower pivot on the clutch housing.

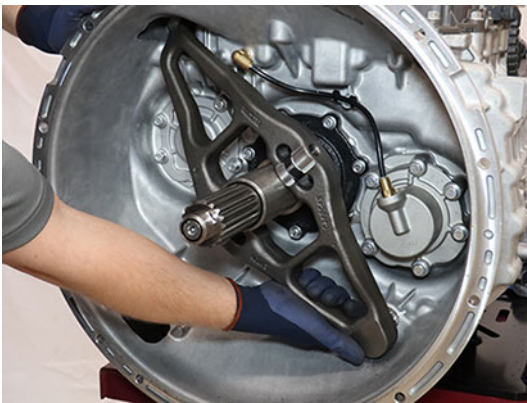

3. Pull to free the upper Clutch Release Yoke socket from the Linear Clutch Actuator (LCA) rod end.



4. Inspect the plastic socket inserts in the Clutch Release Yoke to verify none of the fingers are missing or damaged.

Note: If the plastic insert is damaged, replace the Clutch Release Yoke assembly.



Remove the Lower Countershaft Cover and Inertia Brake

1. Depress and hold collar on air line fitting and disconnect the air line from the Inertia Brake Cover.

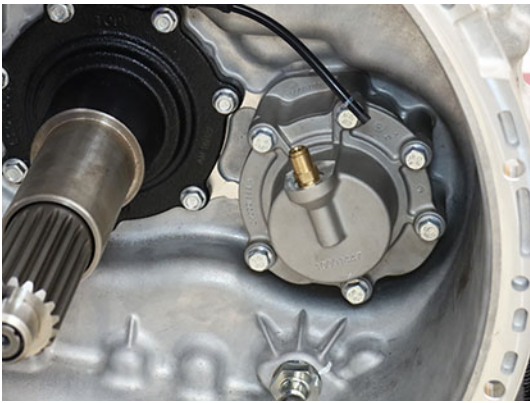

2. Remove the 6 Inertia Brake Cover 13 mm cap screws.



3. Remove the Inertia Brake Cover and Housing as an assembly.



4. Remove Piston Pin from the end of the lower countershaft.



5. Remove the Return Spring from the end of the lower countershaft using a magnet.



Install the Lower Countershaft Cover and Inertia Brake

1. Clean sealing surfaces on the Clutch Housing and Inertia Brake Housing.
2. Install the Inertia Brake Cover and Housing as an assembly over the Lower Countershaft, rotate the assembly to align the Friction Discs to the Lower Countershaft splines and seat the assembly to the clutch housing.

Note: Reference “RRMT0027 - Clutch Housing Front Cover Kit” on page 586 for new Inertia Brake Housing part number, additional O-ring part number, and installation instructions.



3. While holding the Inertia Brake Housing to the clutch housing, remove the Inertia Brake Cover.

NOTICE: Ensure the Friction Discs are splined to the lower countershaft and Wear Guides are fully seated.



4. Install the Return Spring into the Lower Countershaft.



5. Install the Piston Pin into the Lower Countershaft.



6. Install the Inertia Brake Cover onto the housing.



7. Install the 6 13 mm cap screws and torque to 21-25 Nm (16-19 lb-ft) in a criss-cross pattern.



8. Insert air line in push-to-connect fitting on the Inertia Brake Cover.

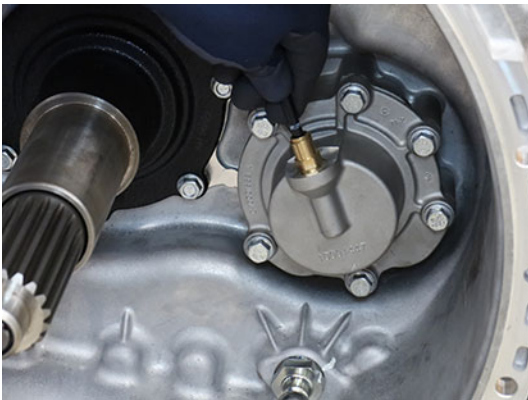

Remove the Linear Clutch Actuator (LCA)

1. Loosen the 4 LCA cap screws 1-2 turns each with a T45 Torx.

NOTICE: Ensure key is off, 20-Way TCM Vehicle and Body Harness Connectors are disconnected, and 5 minutes has passed prior to LCA removal.

Note: Residual air pressure in the LCA cylinder exhausts between the LCA and MTM housing when the cap screws are loosened.



2. Remove the 4 LCA cap screws
3. Remove the LCA from the MTM.

Note: LCA piston rod end is seated in the release yoke socket; pull to release rod end from socket.



- Inspect the plastic socket insert in the release yoke through the LCA opening using a flashlight to verify none of the fingers are missing or damaged.

Note: If the plastic insert is damaged, replace the release yoke assembly.

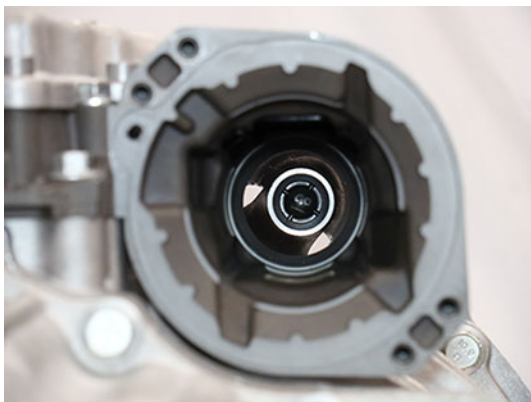

Reset and Install Linear Clutch Actuator (LCA)

- Inspect LCA to determine next steps, reference images below:
 - If LCA is locked in the reset position, go to Install Linear Clutch Actuator (LCA).
 - If LCA is not locked in the reset position, go to Step 2.

Locked in Reset Position

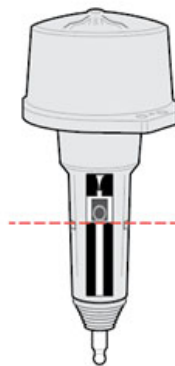

Not Locked in Reset Position

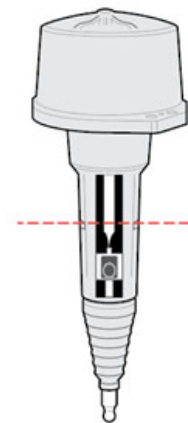

- Place LCA push rod on a clean, flat surface. Tightly grasp LCA housing with both hands and push down on push rod to lock LCA into the reset position.



CAUTION: A large amount of force is required to lock the LCA into the reset position. Failure to tightly grasp the LCA housing with both hands while pushing down on push rod may cause unintended movement resulting in personal injury and/or component damage.



3. Inspect LCA to determine next steps, reference images below:

- If LCA remains locked in the reset position, go to Step 4.
- If LCA does not remain locked in the reset position, go to Step 2, repeat reset procedure.

Note: If LCA cannot be locked into the reset position, replace LCA.



CAUTION: Do not drop LCA. Dropping LCA may cause the LCA to unlock resulting in personal injury and/or component damage.

Locked in Reset Position

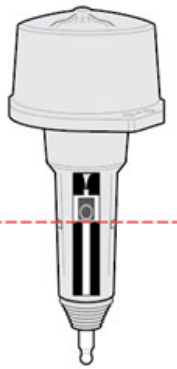

Not Locked in Reset Position

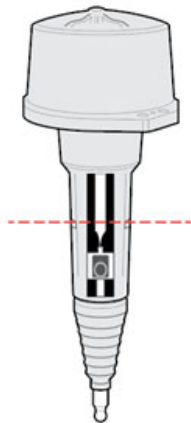

4. Clean all sealing surfaces on the MTM and LCA with a lint free cloth.

NOTICE: Do not use abrasive scrapers or powered tools to clean sealing surfaces or sealing surfaces may be damaged and leak.

5. Insert the LCA into the MTM.



6. Install 4 LCA T45 cap screws and torque to 23-28 Nm (17-21 lb-ft) in a criss-cross pattern.

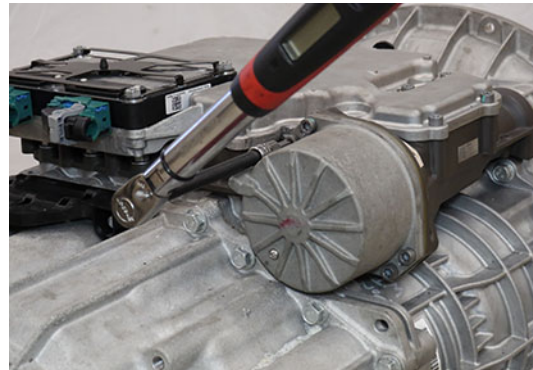

Install the Release Bearing and Clutch Release Yoke

1. Install the upper Release Yoke socket over the rod end of the Linear Clutch Actuator (LCA) and press until attached.



2. Install the lower Release Yoke socket over the lower pivot on the clutch housing and press until attached.

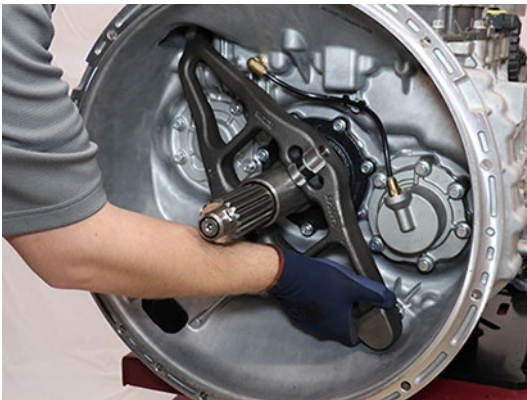

3. Slide the Release Bearing over the input shaft and into the Release Yoke.



Install the Transmission

1. Refer to OEM guidelines for transmission installation.
2. Connect negative battery cable.

Fill Oil

Note: Perform the transmission fill procedure with transmission installed in vehicle to ensure proper transmission angle.

1. Remove the Oil Fill Plug with a 6 mm hex key.

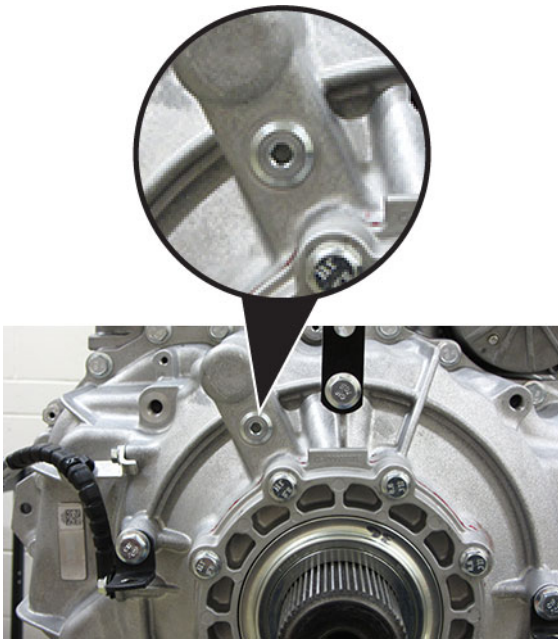

2. Place a suitable container under the Oil Check Plug and remove the Oil Check Plug with a 6 mm hex key.



3. Fill the transmission with PS-386 lube until a small amount of oil runs out of the Oil Check Plug hole.

Note: Fill capacity is approximately 7.5-8.5 liters (16-18 pints) depending on the transmission angle.

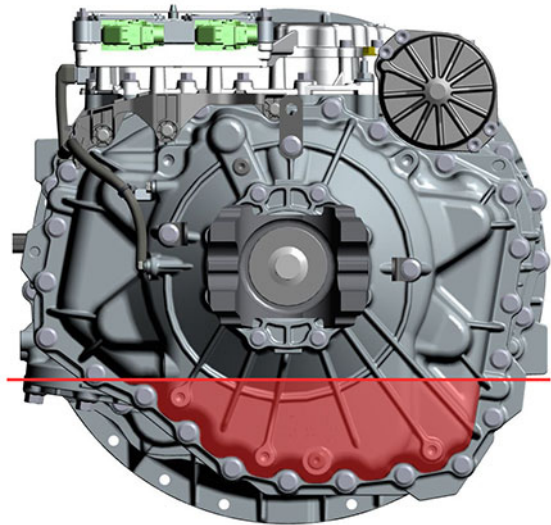
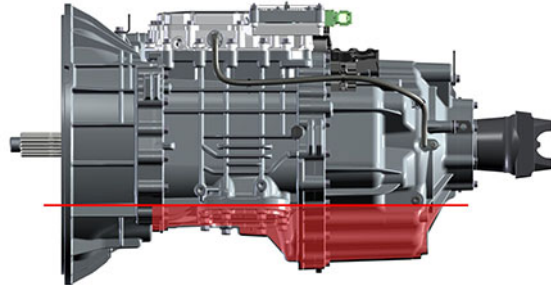

4. Inspect Oil Check Plug and O-ring for damage. If damaged, replace the Oil Check Plug; O-ring is serviced with plug.

5. Install the Oil Check Plug (6 mm) and torque to 24.5-29.5 Nm (18-22 lb-ft).

NOTICE: Do not over-torque the Oil Fill Plug or transmission damage may occur.



6. Inspect Oil Fill Plug and O-ring for damage. If damaged, replace the Oil Fill Plug; O-ring is serviced with plug.
7. Install the Oil Fill Plug (6 mm) and torque to 24.5-29.5 Nm (18-22 lb-ft).

NOTICE: Do not over-torque the Oil Fill Plug or transmission damage may occur.

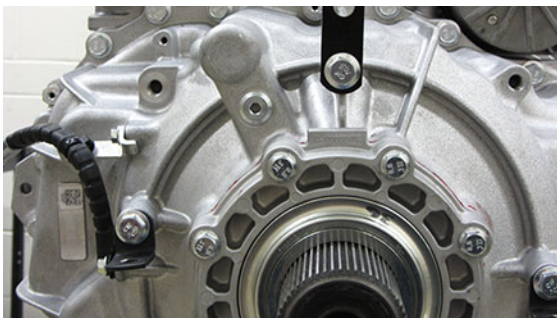

Clutch and Rail Calibration

To ensure proper operation, the TCM, clutch, MTM and transmission require a Clutch and Rail Calibration. Calibrations are automatically initiated when:

- LCA is in the reset position
- Transmission in “N” (Neutral)
- Key on engine running
- Vehicle air system pressure at operating range

NOTICE: Do not use service tool to initiate calibrations. Allow calibrations to automatically initiate.

Note: Vehicle display may indicate a flashing “CC” and “F” in gear display.

1. Set vehicle parking brake and chock wheels.
2. Ensure the driveline is connected between the transmission and axle.

Note: Clutch and Rail Calibrations cannot complete if the transmission output shaft is allowed to rotate.
3. Key on with engine running.
4. Allow vehicle air pressure to build to governor cut-off.

Note: Clutch and Rail Calibrations automatically initiate when vehicle air pressure reaches approximately 100 psi.
5. Ensure “N” (Neutral) is selected and engine is running. Wait approximately 2 minutes for calibrations to complete.

NOTICE: If process is interrupted, key off, wait 1 minute and go to Step 2.

- If vehicle display indicates a solid “N: (Neutral) in gear display, calibrations are complete. Key off, go to Step 6.
 - If vehicle display continues to indicate a flashing “CC” and/or “F” in gear display or service transmission message, go to Step 5.
6. Key off and wait 1 minute.
 7. Key on with engine off.
 8. Connect ServiceRanger.

9. Go to “Fault Codes”.
 - If an Active transmission fault code is set, go to Endurant HD Troubleshooting Guide TRTS0950 **Diagnostic Procedure**.
 - If no Active transmission fault codes are set, select “Clear Eaton Faults” and follow on-screen prompts. Go to Step 9.
10. Disconnect ServiceRanger.
11. Key off.
12. Inspect transmission for a PTO.
 - If not PTO-equipped, process complete.
 - If PTO-equipped, start the engine and run for 1 to 2 minutes to fill the PTO with oil, key off and repeat the Fill Oil Procedure.



CAUTION: Failure to repeat the Fill Oil service procedure to verify proper transmission oil level when equipped with a PTO may result in low transmission oil and component damage.

Output Yoke

Special Instructions

None

Special Tools

None

Component Identification

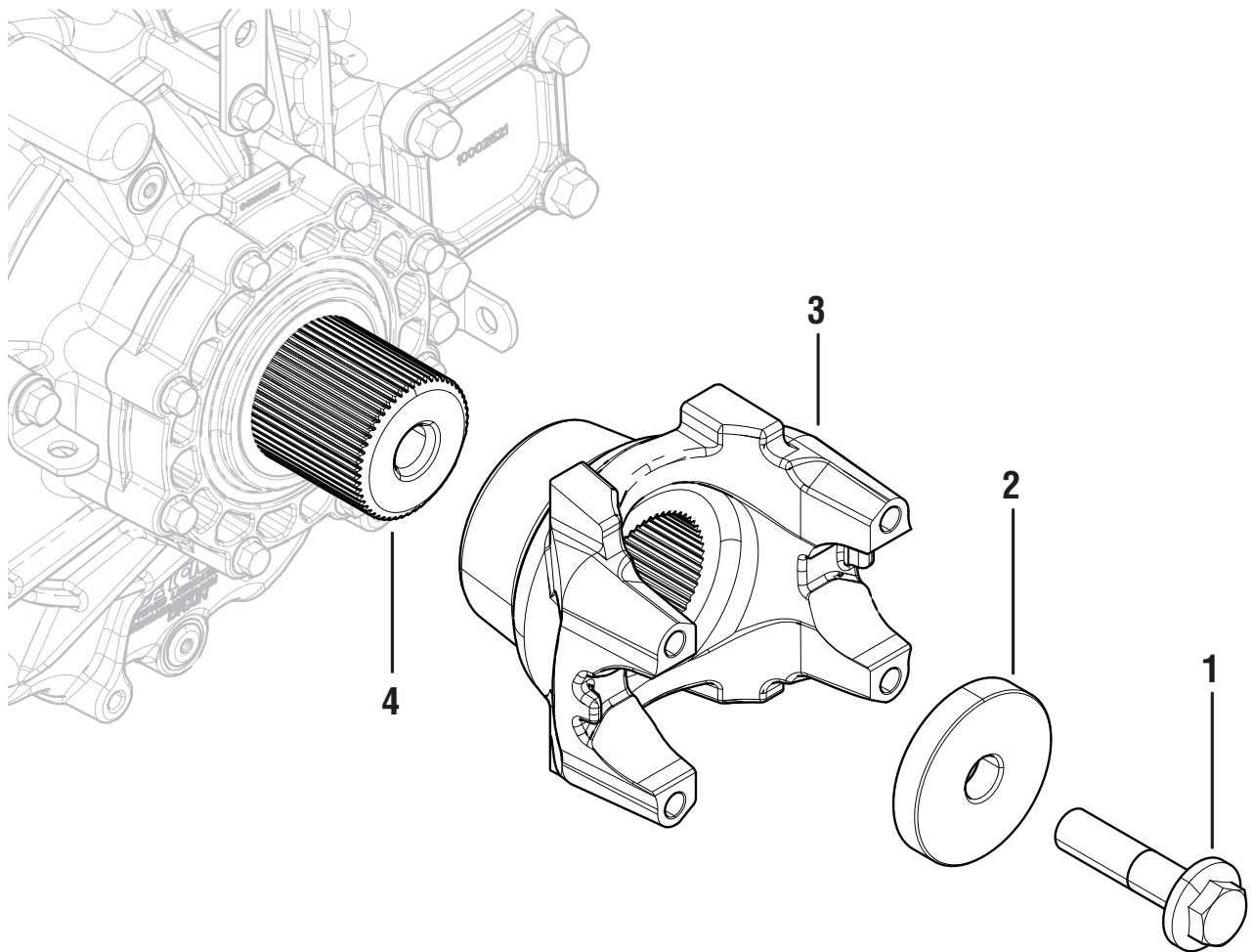

1. Retainer Bolt - 27 mm
2. Retainer Plate
3. Output Yoke
4. Output Shaft

Remove the Output Yoke

Note: Output Yoke is removable with transmission in chassis.

1. Remove the driveline. Refer to OEM guidelines for driveline removal.
2. Remove the 27 mm Retainer Bolt and Retainer Plate.

! **WARNING:** A new Retainer Bolt is required during Output Yoke installation. Failure to replace with a new Retainer Bolt may cause the bolt to loosen during operation and may result in major vehicle component damage, severe injury or death.

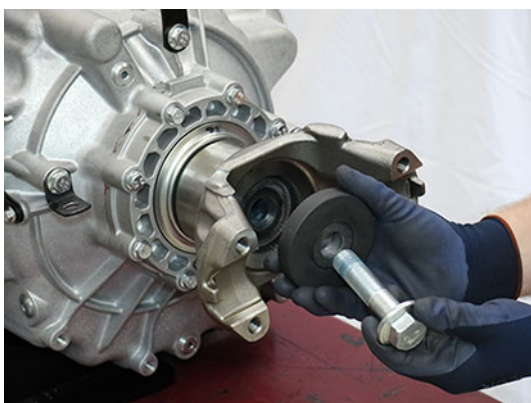

3. Remove the Output Yoke.

Note: An output yoke puller may be required due to spline interference fit.



Install the Output Yoke

1. Clean the mating surfaces and splines on the output shaft and Output Yoke.
2. Slide the Output Yoke over the output shaft.

Note: The Output Yoke may require to be driven on due to spline interference fit.



3. Install the Retainer Plate and a new 27 mm Retainer Bolt and torque to 617-690 Nm (455-508 lb-ft).

! **WARNING:** A new Retainer Bolt is required during Output Yoke installation. Failure to replace with a new Retainer Bolt may cause the bolt to loosen during operation and may result in major vehicle component damage, severe injury or death.



Rear Bearing Cover

Special Instructions

The Rear Bearing Cover can be removed and installed with the transmission in-vehicle.

Special Tools

- Gasket Sealant (Loctite 5188)
- Plastic Scraper
- Non-Chlorinated Brake Cleaner (Gasket Remover)



DANGER: Do not handle non-chlorinated brake cleaner until all manufacturer precautions have been read and understood. Failure to follow precautions will result in serious personal injury or death.



CAUTION: Avoid contact between non-chlorinated brake cleaner and the transmission plastic components, electrical wiring and connectors. Failure to avoid contact will result in transmission component damage.

Component Identification

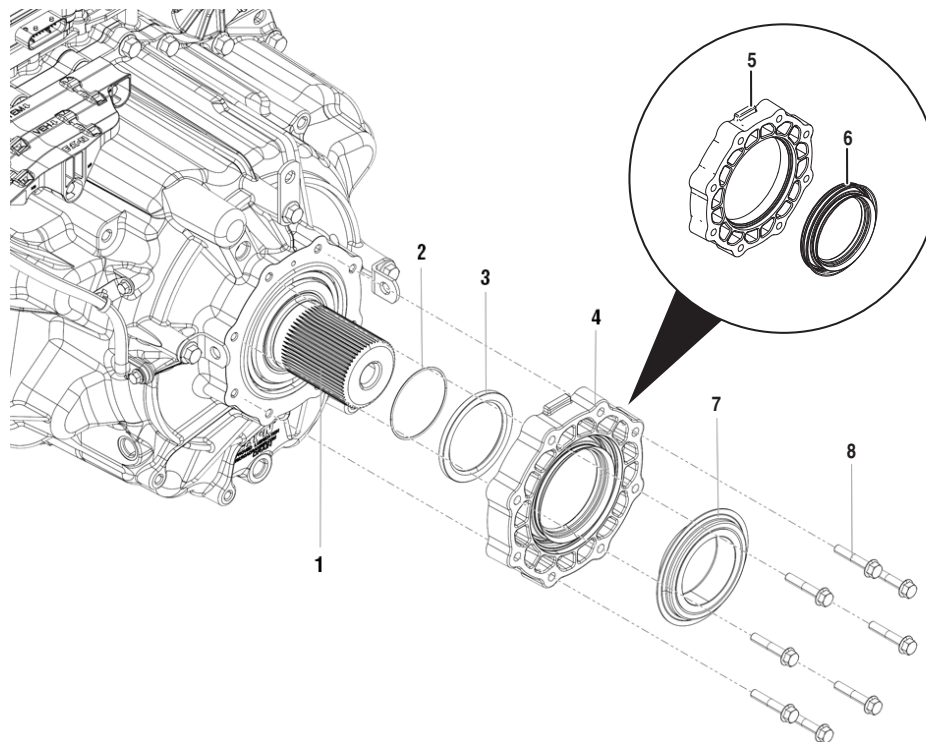

1. Output Shaft
2. Thrust Washer
3. O-Ring
4. Rear Bearing Cover with Output Shaft Seal pressed in

5. Rear Bearing Cover
6. Output Shaft Seal
7. Wear Sleeve and Dust Cover
8. Cap Screws (x8) - 13 mm

Drain Oil

1. Locate the Oil Drain Plug on the back of the rear housing.

2. Place a suitable container under the Oil Drain Plug.

Note: If reusing oil, use a clean container free of contamination and debris.

3. Remove the Oil Drain Plug with a 6 mm hex key and drain the oil.



4. If PTO-equipped, remove PTO and drain the oil.
5. Inspect Oil Drain Plug and O-ring for damage. If damaged, replace the Oil Drain Plug; O-ring is serviced with plug.
6. Install the Oil Drain Plug (6 mm) and torque to 24.5-29.5 Nm (18-22 lb-ft).

NOTICE: Do not over-torque drain plug or transmission damage may occur.



Remove the Output Yoke

Note: Output Yoke is removable with transmission in chassis.

1. Remove the driveline. Refer to OEM guidelines for driveline removal.
2. Remove the 27 mm Retainer Bolt and Retainer Plate.



WARNING: A new Retainer Bolt is required during Output Yoke installation. Failure to replace with a new Retainer Bolt may cause the bolt to loosen during operation and may result in major vehicle component damage, severe injury or death.



3. Remove the Output Yoke.

Note: An output yoke puller may be required due to spline interference fit.



Remove the Rear Bearing Cover

1. Remove the 8 Rear Bearing Cover 13 mm Cap Screws.



2. Using a pry bar, separate the Rear Bearing Cover from the rear housing.

Note: Two pry points located at 12 and 6 o'clock.



3. Remove the Rear Bearing Cover, Wear Sleeve and Dust Cover.

NOTICE: If replacing the Output Seal, a new Rear Bearing Cover is required when reinstalling or an oil leak may occur.

NOTICE: Ensure Output Shaft Seal is pressed in new Rear Bearing Cover.

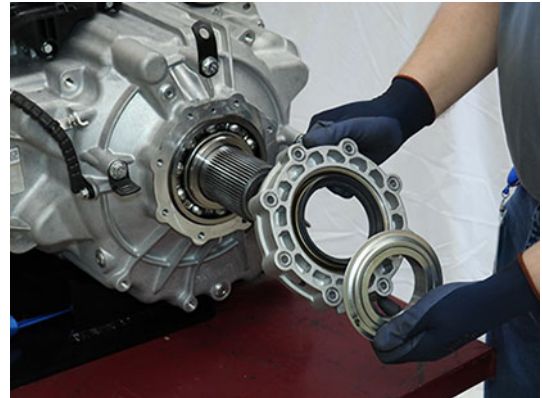

4. Remove the O-ring.

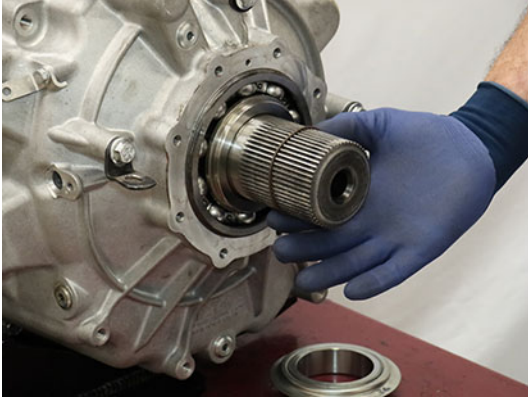

5. Remove the Output Shaft Thrust Washer.



Assemble the Output Seal

1. Place the Rear Bearing Cover on a flat clean surface the pry points down.

NOTICE: A new Rear Bearing Cover is required when replacing the Output Seal to ensure no leaks occur between the cover and new seal.



2. Place the Output Seal Driver (RR1001TR-8) onto the Output Seal Driver Handle (RR1001TR-2).
3. Place the Output Seal onto the Output Seal Driver (RR1001TR-8).



4. Install the Output Seal and driver assembly into the Rear Bearing Cover and drive until the seal is seated against the cover.

NOTICE: Fully seat Output Seal into Bearing Cover.



Install the Rear Bearing Cover

1. Clean the sealing surfaces on the transmission and Rear Bearing Cover with gasket remover.

NOTICE: Do not use abrasive scrapers or powered tools to clean sealing surfaces or sealing surfaces may be damaged and leak.
2. Inspect threaded bolt holes for debris and clean if necessary.

NOTICE: Ensure there is nothing in the threaded bolt holes or the transmission may be damaged when cap screws are tightened.

3. Slide the Output Shaft Thrust Washer over the output shaft and seat it against the Output Bearing.



4. Slide the O-ring over the output shaft and seat it against the Output Shaft Thrust Washer.

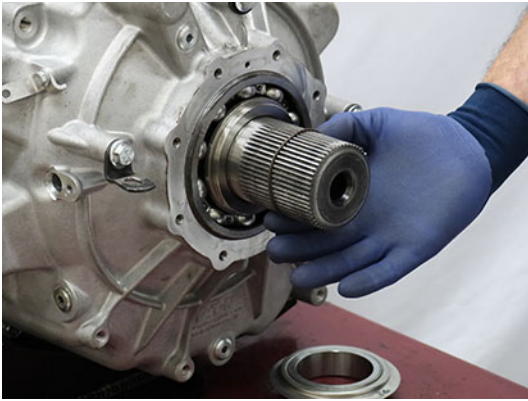

5. Clean the sealing surfaces on the transmission and Mechatronic Transmission Module (MTM) with gasket remover and a plastic scraper. Let air dry then wipe with a clean dry cloth.

NOTICE: Do not use abrasive scrapers or powered tools to clean sealing surfaces or sealing surfaces may be damaged and leak.

6. Apply Gasket Sealant with a bead width of 1.4-2.4 mm (0.055-0.094 inch) to the rear housing as shown in the pattern below.

NOTICE: Ensure there is nothing in the threaded bolt holes or the transmission may be damaged when cap screws are tightened.

Note: Parts must be assembled within 10 minutes of applying Gasket Sealant.

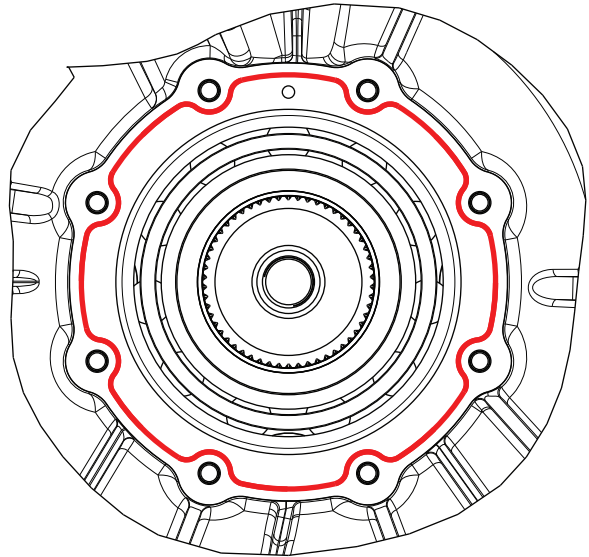

7. Slide the Rear Bearing Cover over the output shaft.

Note: Align the two pry points at 12 and 6 o'clock positions.



8. Install 8 Rear Bearing Cover 13 mm Cap Screws and torque to 21-25 Nm (16-19 lb-ft) in a criss-cross pattern.



9. Slide the Wear Sleeve and Dust Cover over the output shaft.



Install the Output Yoke

1. Clean the mating surfaces and splines on the output shaft and Output Yoke.
2. Slide the Output Yoke over the output shaft.

Note: The Output Yoke may require to be driven on due to spline interference fit.



3. Install the Retainer Plate and a new 27 mm Retainer Bolt and torque to 617-690 Nm (455-508 lb-ft).

! **WARNING:** A new Retainer Bolt is required during Output Yoke installation. Failure to replace with a new Retainer Bolt may cause the bolt to loosen during operation and may result in major vehicle component damage, severe injury or death.



Fill Oil

Note: Perform the transmission fill procedure with transmission installed in vehicle to ensure proper transmission angle.

1. Remove the Oil Fill Plug with a 6 mm hex key.

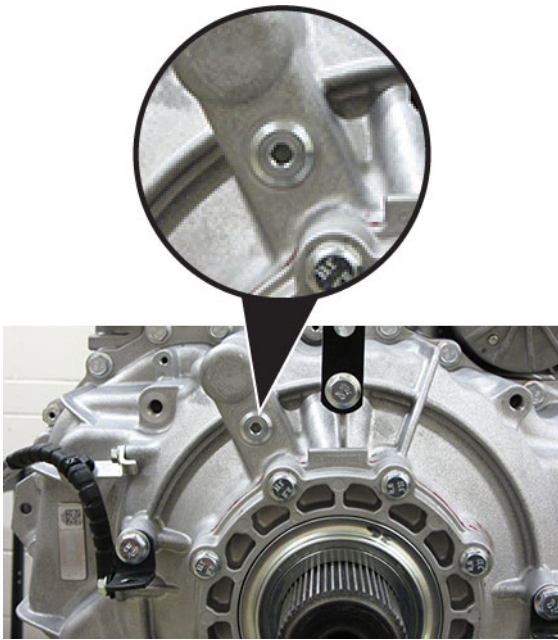

2. Place a suitable container under the Oil Check Plug and remove the Oil Check Plug with a 6 mm hex key.



3. Fill the transmission with PS-386 lube until a small amount of oil runs out of the Oil Check Plug hole.

Note: Fill capacity is approximately 7.5-8.5 liters (16-18 pints) depending on the transmission angle.

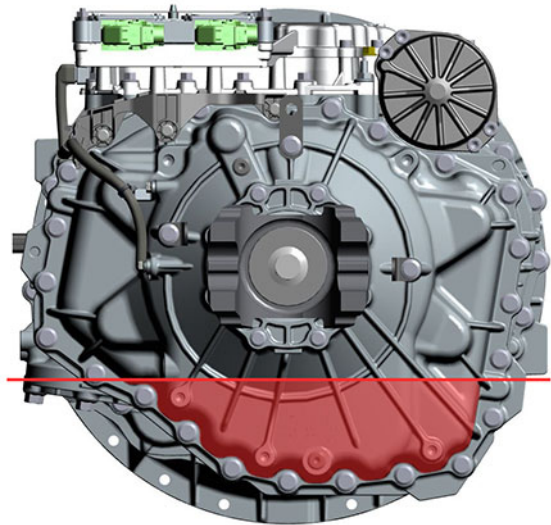
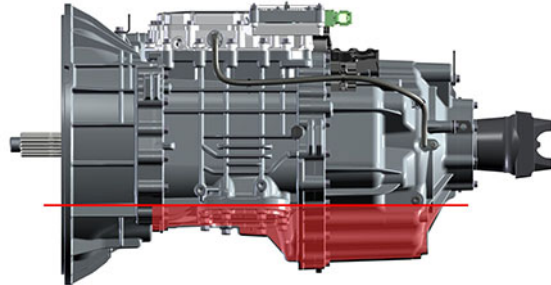

4. Inspect Oil Check Plug and O-ring for damage. If damaged, replace the Oil Check Plug; O-ring is serviced with plug.

5. Install the Oil Check Plug (6 mm) and torque to 24.5-29.5 Nm (18-22 lb-ft).

NOTICE: Do not over-torque the Oil Fill Plug or transmission damage may occur.



6. Inspect Oil Fill Plug and O-ring for damage. If damaged, replace the Oil Fill Plug; O-ring is serviced with plug.
7. Install the Oil Fill Plug (6 mm) and torque to 24.5-29.5 Nm (18-22 lb-ft).

NOTICE: Do not over-torque the Oil Fill Plug or transmission damage may occur.

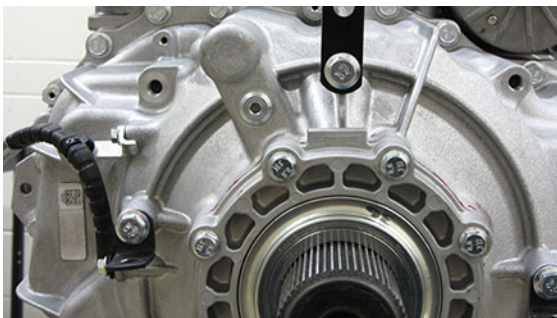

8. Inspect transmission for a PTO.
 - If not PTO-equipped, process complete.
 - If PTO-equipped, start the engine and run for 1 to 2 minutes to fill the PTO with oil, key off and repeat the Fill Oil Procedure.



CAUTION: Failure to repeat the Fill Oil service procedure to verify proper transmission oil level when equipped with a PTO may result in low transmission oil and component damage.

Harness Bracket

Special Instructions

The Harness Bracket can be removed and installed with the transmission in-vehicle.

Special Tools

None

Component Identification

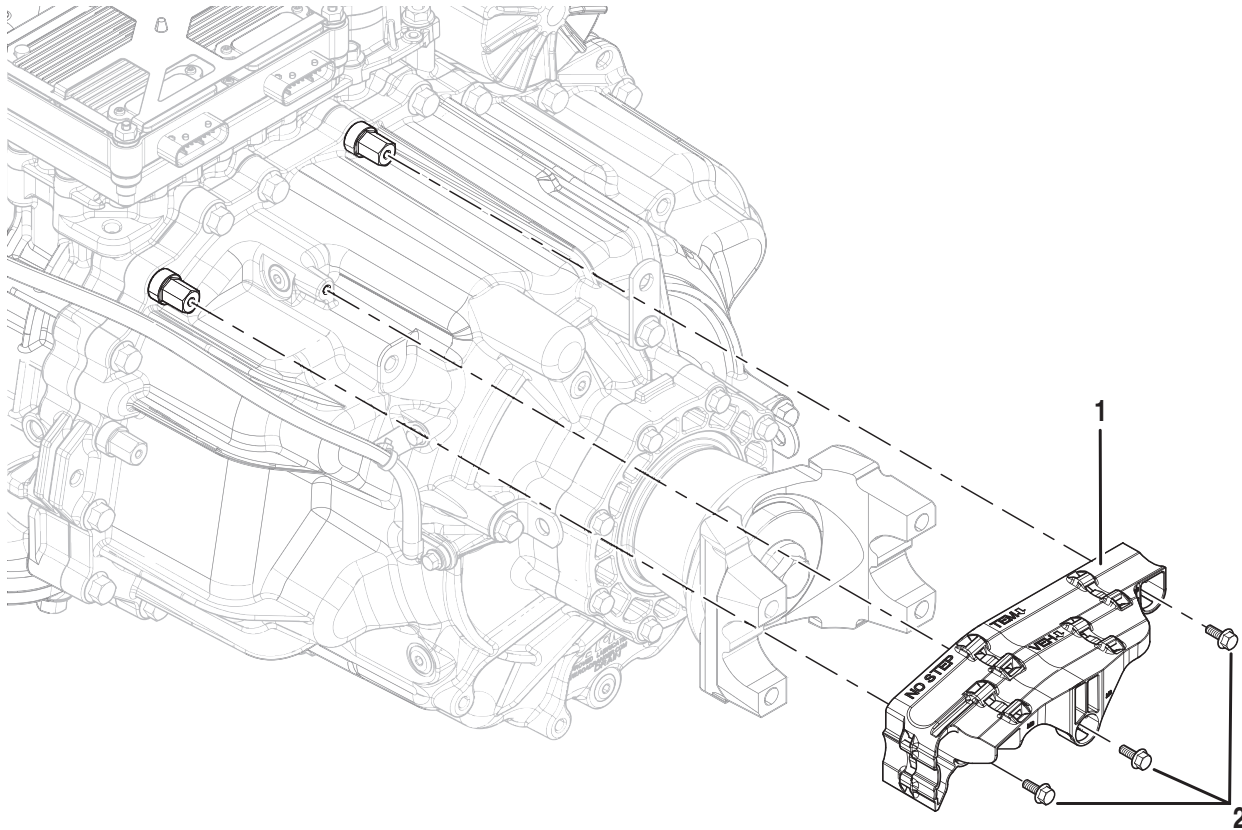

1. Harness Bracket
2. Harness Bracket Cap Screws (x3) - 10 mm

Remove the Harness Bracket

1. Remove the Output Speed Sensor Harness tie strap at the Harness Bracket.



2. Remove 3 Harness Bracket 10 mm cap screws.



3. Remove Harness Bracket.



Install the Harness Bracket

1. Install Harness Bracket.



2. Install 3 Harness Bracket 10 mm cap screws and torque to 8.8 - 10.4 Nm (6-8 lb-ft).

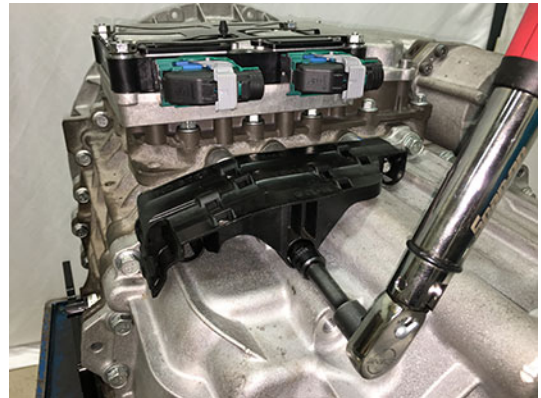

Rear Housing

Special Instructions



WARNING: Rear Housing Assembly weighs approximately 170 lbs. Failure to properly secure and lift the Rear Housing Assembly may result in major vehicle component damage, severe injury or death.



DANGER: Do not handle non-chlorinated brake cleaner until all manufacturer precautions have been read and understood. Failure to follow precautions will result in serious personal injury or death.



CAUTION: Avoid contact between non-chlorinated brake cleaner and the transmission plastic components, electrical wiring and connectors. Failure to avoid contact will result in transmission component damage.

Special Tools

- Rear Housing Alignment Pins (RR1090TR)
- Gasket Sealant (Loctite 5188)
- Plastic Scraper
- Non-Chlorinated Brake Cleaner (Gasket Remover)

Component Identification

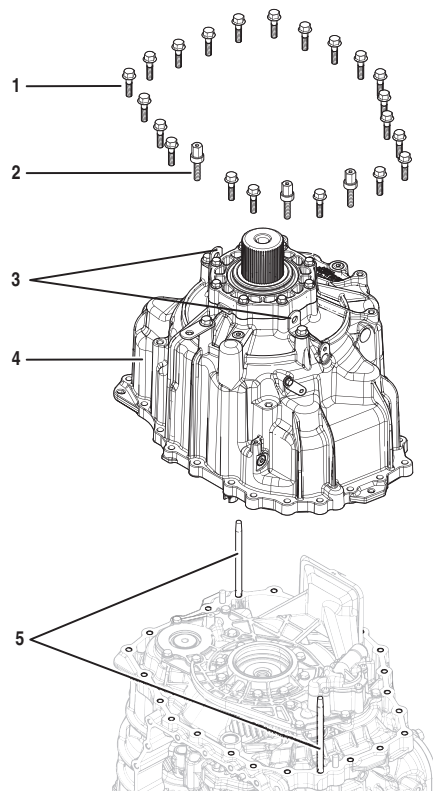

1. Rear Housing Cap Screws (x21) - 16 mm
2. Rear Housing Threaded Cap Screws (x3) - 16 mm
3. 90-Degree Lifting Eyes (x2)

4. Rear Housing
5. Rear Housing Alignment Pins (x2)

Create a Service Activity Report

Note: If not already created and sent.

1. Key on with engine off.
2. Connect ServiceRanger and create a Service Activity Report.
3. Select "Send to Eaton" (internet connection required)
4. Disconnect ServiceRanger.
5. Key off.

Drain Oil

1. Locate the Oil Drain Plug on the back of the rear housing.
2. Place a suitable container under the Oil Drain Plug.
Note: If reusing oil, use a clean container free of contamination and debris.
3. Remove the Oil Drain Plug with a 6 mm hex key and drain the oil.

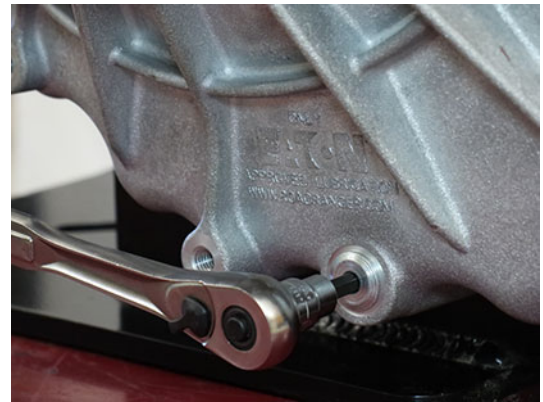

4. If PTO-equipped, remove PTO and drain the oil.
5. Inspect Oil Drain Plug and O-ring for damage. If damaged, replace the Oil Drain Plug; O-ring is serviced with plug.
6. Install the Oil Drain Plug (6 mm) and torque to 24.5-29.5 Nm (18-22 lb-ft).

NOTICE: Do not over-torque drain plug or transmission damage may occur.



Manually Vent Linear Clutch Actuator (LCA)

1. Key off.
2. Set vehicle parking brake and chock wheels.

! **WARNING:** Apply vehicle parking brake and follow vehicle manufacture parking instructions. Failure to follow these instructions could cause unintended vehicle movement and may result in major vehicle component damage, severe injury or death.

3. Loosen the 4 Linear Clutch Actuator (LCA) cap screws 1-2 turns each with a T45 Torx.

Note: Residual air pressure in the LCA cylinder exhausts between the LCA and Mechatronic Transmission Module (MTM) housing when the cap screws are loosened.

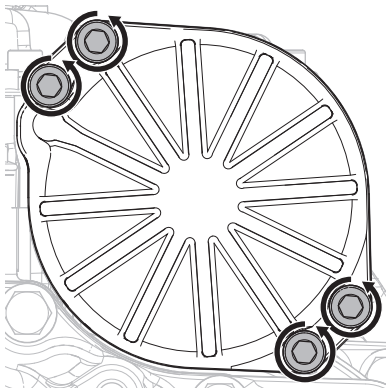

4. Tighten the 4 LCA to MTM T45 cap screws and torque to 23-27 Nm (17-21 lb-ft).

Remove the Transmission

1. Disconnect negative battery cable.
2. Refer to OEM guidelines for transmission removal.

Remove the Transmission Control Module (TCM)

1. Unscrew the 4 TCM Cover nuts and remove TCM Cover.

Note: TCM Cover nuts are 10 or 13 mm.



2. Unscrew the TCM 7 mm Jackscrew. Lift and remove the TCM from the MTM.

NOTICE: Do not allow contamination into the connectors on the TCM or MTM.



3. Inspect the TCM Seal for damage.

NOTICE: Replace the TCM Seal if damaged.

Note: If replacing the TCM, the REMAN TCM includes a new seal.



Remove the Release Bearing and Clutch Release Yoke

1. Remove the Release Bearing by sliding the bearing off the input shaft.



2. Pull to free the lower Clutch Release Yoke socket from the lower pivot on the clutch housing.



3. Pull to free the upper Clutch Release Yoke socket from the Linear Clutch Actuator (LCA) rod end.



4. Inspect the plastic socket inserts in the Clutch Release Yoke to verify none of the fingers are missing or damaged.

Note: If the plastic insert is damaged, replace the Clutch Release Yoke assembly.



Remove the Mechatronic Transmission Module (MTM)

1. Lift the latch on the Output Speed Sensor Harness at the Connector on the Mechatronic Transmission Module (MTM).



2. Remove the Output Speed Sensor Harness from the Connector on the MTM.



3. Remove the 20 MTM cap screws.

Note: 13 mm (x18), 15 mm (x2).



4. Separate the MTM from the Main Housing at the 2 pry points.

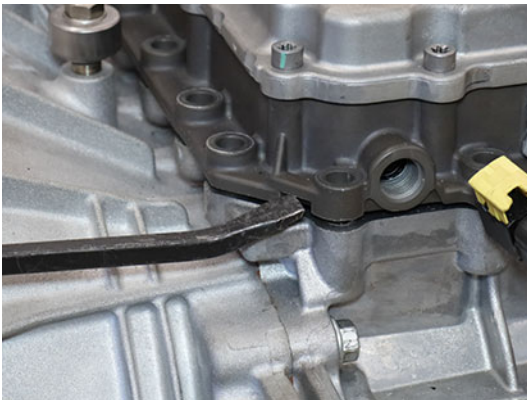
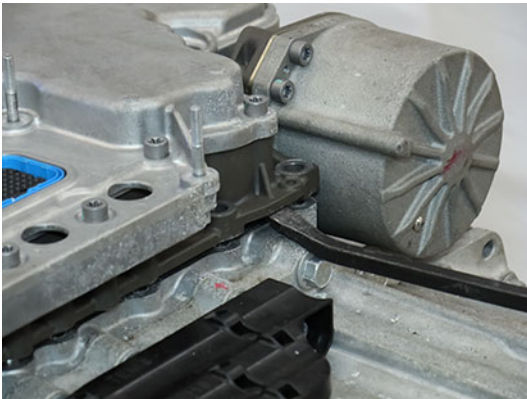

5. Remove the MTM from the transmission housing.

⚠ CAUTION: MTM weighs approximately 40 lbs. Keep fingers clear of pinch point between MTM and other surfaces. Dropping MTM could result in component damage and/or personal injury.



Remove the Output Speed Sensor

1. Remove the Output Speed Sensor Harness tie strap at the Harness Bracket.



2. Remove the 2 harness press-in retainers from the Main Housing and bracket on Rear Housing.



3. Remove the Output Speed Sensor 10 mm cap screw.



4. Remove the Output Speed Sensor from the Rear Housing.

Note: The sensor may need to be twisted and pulled from the bore.



Remove the Harness Bracket

Note: This procedure contains removing the Harness Bracket without the Mechatronic Transmission Module (MTM).

1. Remove 3 Harness Bracket 10 mm cap screws.



2. Remove Harness Bracket.



Secure Transmission (Vertical)

1. Place transmission in the vertical position with the front side down.



WARNING: Transmission weighs approximately 550 lbs. Keep fingers clear of pinch point between transmission and other surfaces. Dropping transmission may result in major vehicle component damage, severe injury or death.

NOTICE: Use an appropriate lifting device to safely lift component.

Note: Use a surface with an opening that allows the input shaft to pass through and the clutch housing to sit flat and secure.

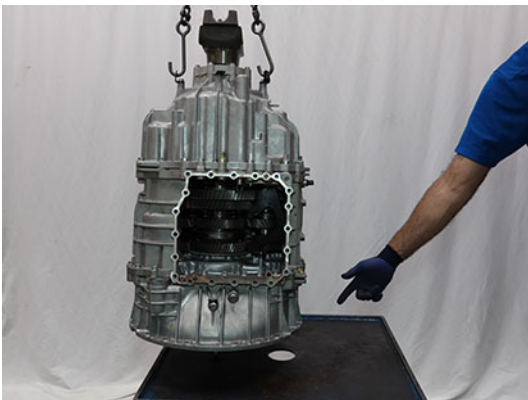

Remove the Rear Housing

1. At the 3 Rear Housing Threaded cap screws, apply paint marks on the Rear Housing to identify location.



2. Remove 21 Rear Housing and 3 threaded 16 mm cap screws.



3. Install and hand tighten 2 Rear Housing Alignment Pins (RR1090TR) 180-degrees apart.

NOTICE: Failure to install alignment pins results in transmission component damage.



4. Separate the Rear Housing from the Main Housing at the 2 pry points.



5. Lift and remove Rear Housing Assembly from Main Housing.



WARNING: Rear Housing Assembly weighs approximately 170 lbs. Failure to properly secure and lift the Rear Housing Assembly may result in major vehicle component damage, severe injury or death.

NOTICE: Use an appropriate lifting device to safely lift component.

Note: Dual PTO Transmissions are equipped with a rear PTO lube tube port on the pump and rear PTO drive splines on the Upper Countershaft.

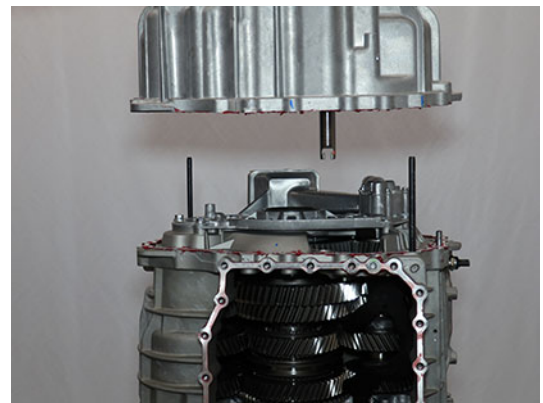

- Place Rear Housing Assembly on bench.



WARNING: Rear Housing Assembly weighs approximately 170 lbs. Keep fingers clear of pinch point between Rear Housing Assembly and other surfaces. Dropping Rear Housing may result in major vehicle component damage, severe injury or death.

NOTICE: Support the Rear Housing Assembly to prevent damage to Shift Rail E.



- Remove the 2 Rear Housing Alignment Pins (RR1090TR) from the Main Housing.

Install the Rear Housing

- Clean the sealing surfaces on the transmission Main Housing and Rear Housing with gasket remover and a plastic scraper. Let air dry then wipe with a clean dry cloth.

NOTICE: Do not use abrasive scrapers or powered tools to clean sealing surfaces or sealing surfaces may be damaged and leak.

- Inspect threaded bolt holes for debris and clean if necessary.

- Apply Gasket Sealant with a bead width of 1.4-2.4 mm (0.055-0.094 inch) to the transmission Main Housing sealing surface following the pattern below.

NOTICE: Ensure there is nothing in the threaded bolt holes or the transmission housing may be damaged when cap screws are tightened.

Note: Parts must be assembled within 10 minutes of applying Gasket Sealant.

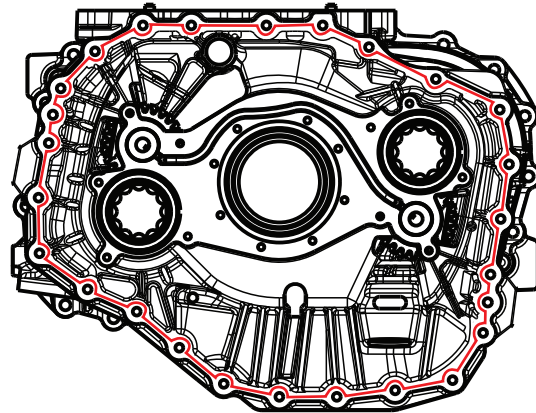

4. Install and hand tighten 2 Rear Housing Alignment Pins (RR1090TR) 180-degrees apart.



CAUTION: Failure to install alignment pins results in transmission component damage during Rear Housing Assembly installation.

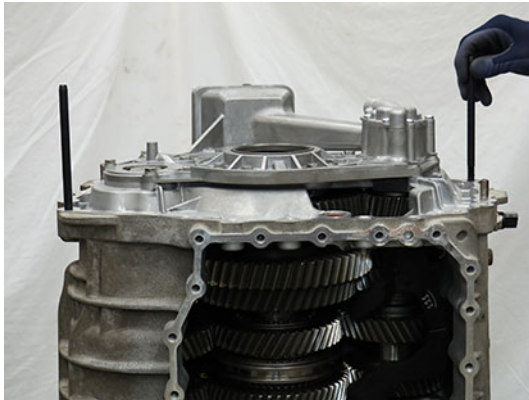

6. Install the 3 Rear Housing Threaded 16 mm cap screws at the 3 paint mark locations.

Note: Two cap screws are used to mount the harness bracket and the third is used by the OEM for additional attachment points.



5. Lift and install the Rear Housing Assembly on to the Main Housing.



WARNING: Rear Housing Assembly weighs approximately 170 lbs. Failure to properly secure and lift the Rear Housing may result in major vehicle component damage, severe injury or death.

NOTICE: Use an appropriate lifting device to safely lift component.

Note: Align the Rear Housing to the alignment pins and align Shift Rail E into the Main Housing during installation.

Note: Rotate Output Shaft to align gearing and allow Rear Housing Assembly to fully seat on Main Housing.



7. Remove the 2 Rear Housing Alignment Pins (RR1090TR).

8. Install the remaining 21 Rear Housing 16 mm cap screws and torque to 44.5 - 51.5 Nm (33-38 lb-ft) in a criss-cross pattern.

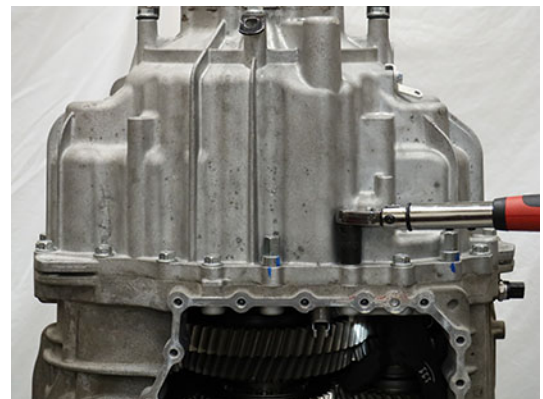

9. Lift transmission horizontally onto a bench.



WARNING: Transmission weighs approximately 550 lbs. Keep fingers clear of pinch point between transmission and other surfaces. Dropping transmission may result in major vehicle component damage, severe injury or death.

NOTICE: Use an appropriate lifting device to safely lift component.

Install the Harness Bracket

Note: This procedure contains installing the Harness Bracket without the Mechatronic Transmission Module (MTM).

1. Install Harness Bracket.



2. Install 3 Harness Bracket 10 mm cap screws and torque to 8.8 - 10.4 Nm (6-8 lb-ft).



Install the Output Speed Sensor

1. Clean the sensor bore.

NOTICE: Do not use abrasive scrapers or powered tools to clean sealing surface.

2. Apply a light coat of transmission oil to the sensor O-ring.

3. Install the Output Speed Sensor into the bore.

Note: The Sensor may need to be twisted and pushed into the bore.



4. Install the Output Speed Sensor 10 mm cap screw and torque to 8.8-10.4 Nm (6-8 lb-ft).



5. Press the 2 harness press-in retainers into the Main Housing and the bracket on the rear housing.



6. Secure the Output Speed Sensor Harness to the Harness Bracket with a tie strap.



CAUTION: Failure to tie strap the Output Speed Sensor Harness to the Harness Bracket may result in harness damage.

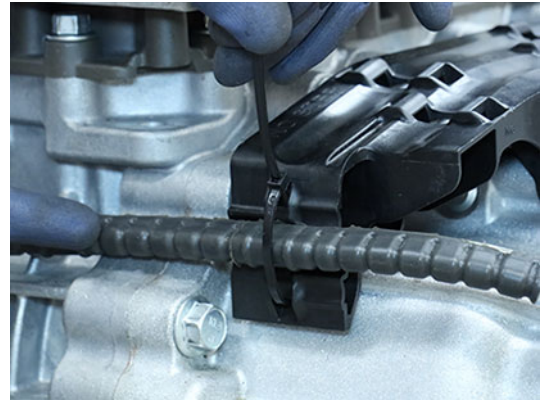

Install the Mechatronic Transmission Module (MTM)

Note: If replacing original equipment MTM with new/replacement MTM locate new/replacement MTM part information tag and record Part Number and Serial Number. Refer to Component Identification section. Part Number and Serial Number are required to properly configure TCM after MTM installation.

1. Place the transmission in a horizontal position.

NOTICE: The transmission must be in a horizontal position prior to the MTM Installation procedure. Failure to do so causes the sliding clutches to move out of neutral and not align to the shift yokes. If the shift yokes are not aligned to the sliding clutches, position sensor fault codes set Active and the transmission will not shift out of neutral.

2. Clean the sealing surfaces on the transmission and Mechatronic Transmission Module (MTM) with gasket remover and a plastic scraper. Let air dry then wipe with a clean dry cloth.

NOTICE: Do not use abrasive scrapers or powered tools to clean sealing surfaces or sealing surfaces may be damaged and leak.

3. Inspect threaded bolt holes for debris and clean if necessary.

NOTICE: Ensure there is nothing in the threaded bolt holes or the transmission may be damaged when cap screws are tightened.

4. Install the Rail B Engagement Tool (RR1088TR) to the Main Housing and hand tighten with 2 MTM cap screws.



5. Shift the Rail B Synchronizer to neutral.

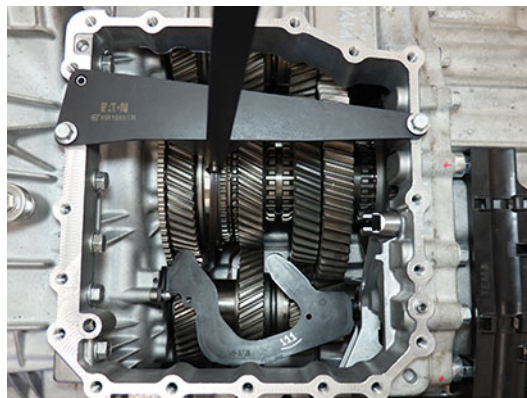

6. Remove the Rail B Engagement Tool.
7. Move Rail C and Rail D sliding clutches to neutral.

NOTICE: The transmission must be in a horizontal position prior to the MTM Installation procedure. Failure to do so causes the sliding clutches to move out of neutral and not align to the shift yokes. If the shift yokes are not aligned to the sliding clutches, position sensor fault codes set Active and the transmission will not shift out of neutral.



8. Install the Confirm-Neutral Gauge (RR1086TR-2) into the slots of the synchronizer and sliding clutches.

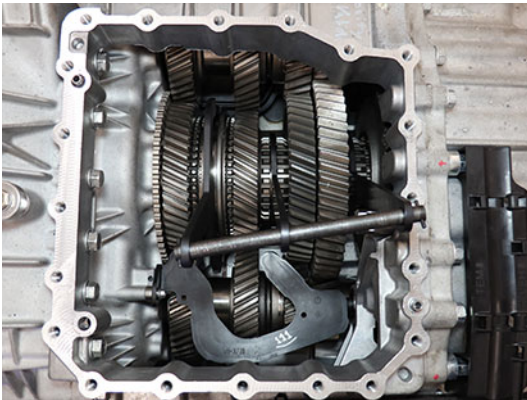

9. Install the MTM Alignment Tool (RR1086TR-1) onto the main housing.

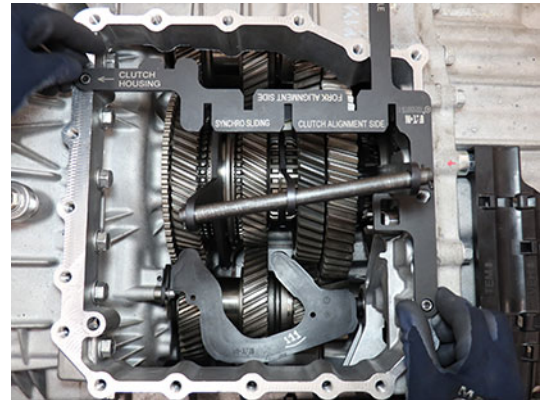
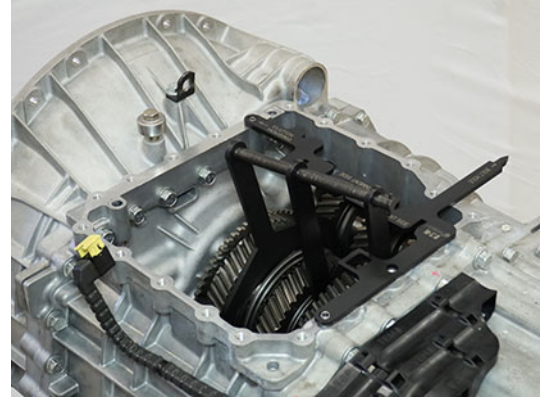

10. Verify synchronizer and sliding clutches are in neutral by sliding Confirm-Neutral Gauge into the slots of MTM Alignment Tool.

Note: If the gauge does not slide into the alignment tool slots, neutral is not achieved. Go to Step 4.

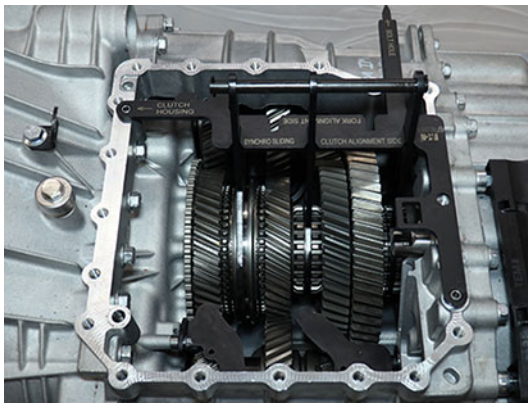
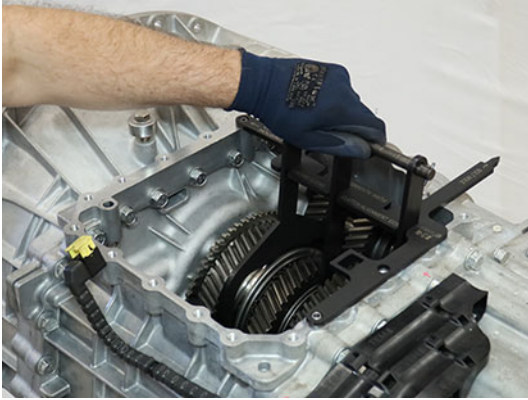

11. Using the Rail E Lever, move Rail E to neutral.

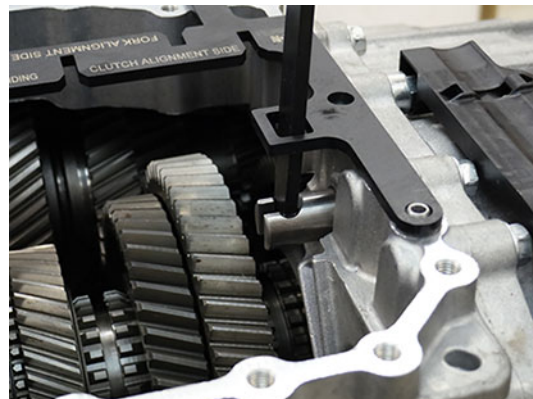
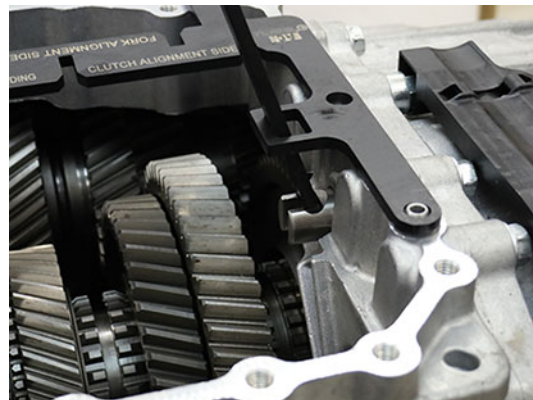
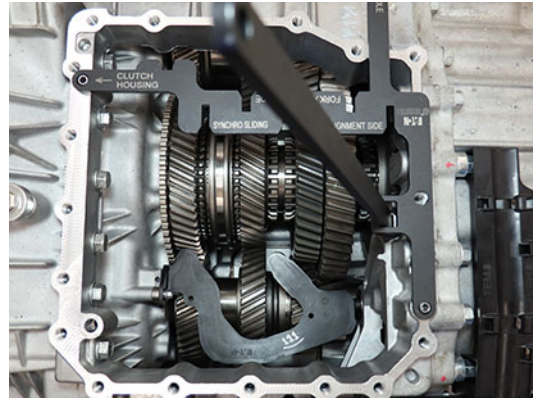

- 12.** Verify Rail E is in neutral using the Gear Side Actuator end of the Confirm-Neutral Gauge (RR1088TR-2) at Shift Rail E. Rail E is in neutral when end of gauge rests against housing with rail against notch-end of gauge.

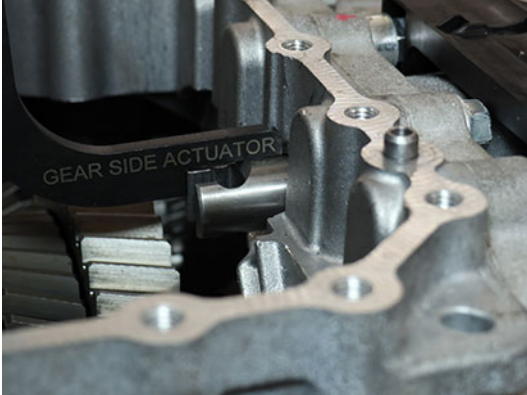

- 13.** Move Shift Rail B in the MTM to neutral. Rail B is in neutral when the ball detent is in the notch of the Rail B yoke assembly.

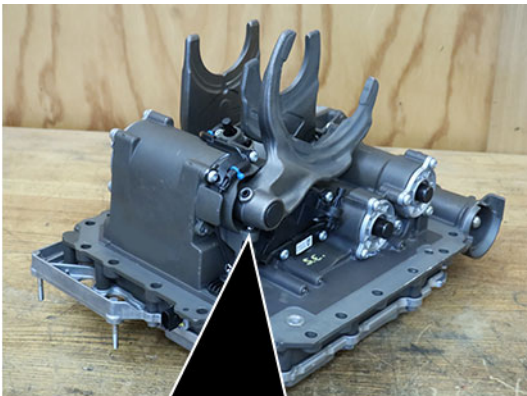

- 14.** Move Shift Rails C and D in the MTM to neutral. Rails C and D are in neutral when the shift inter-lock is aligned with the notches of the rail yoke assemblies.

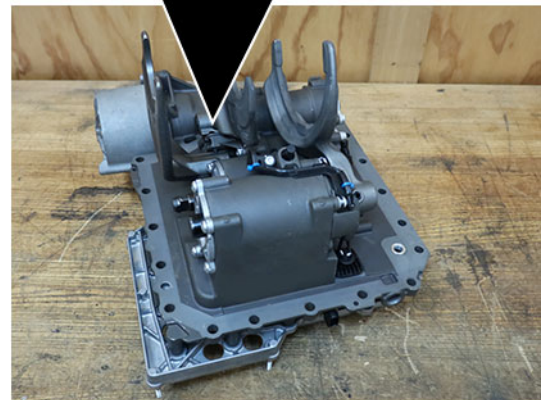

15. Verify MTM is in neutral. Install the MTM Alignment Tool (RR1086TR-1) into the bolt hole and onto Rail B, C, and D Shift Yokes.

Note: If the MTM Alignment Tool slots do not align with the 3 shift yokes, neutral has not been achieved. Go to Step 13.



17. Verify Rail E is in neutral using the Fork Side Actuator end of the Confirm-Neutral Gauge (RR1088TR-2) at Shift Rail E. Rail E is in neutral when end of gauge rests against cover with rail against notch-end of gauge.

Note: If Rail E is not in neutral, slide rail in or out until neutral is achieved.



16. Verify notch on Rail E is facing up.

Note: If MTM is installed on transmission with notch on Rail E facing down, Fault Code/SPN 320/5942 sets Active and transmission does not shift out of neutral.

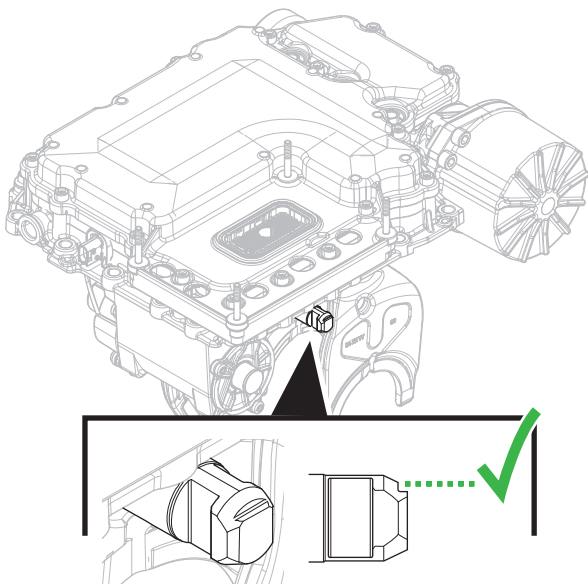

18. Slide O-ring over the MTM front alignment pin on the main housing until fully seated in the groove.

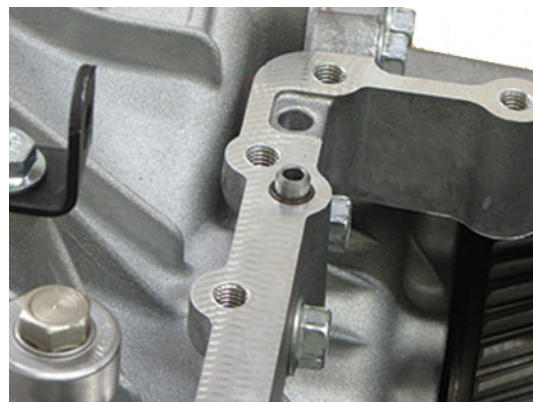

19. Clean the sealing surfaces on the transmission and Mechatronic Transmission Module (MTM) with gasket remover and a plastic scraper. Let air dry then wipe with a clean dry cloth.

NOTICE: Do not use abrasive scrapers or powered tools to clean sealing surfaces or sealing surfaces may be damaged and leak.

20. Apply gasket sealant with a bead width of 1.4-2.4mm (0.055-0.094 inch) to the transmission housing sealing surface following the pattern below.

NOTICE: Ensure there is nothing in the threaded bolt holes or the transmission may be damaged when cap screws are tightened.

Note: Parts must be assembled within 10 minutes of applying Gasket Sealant.

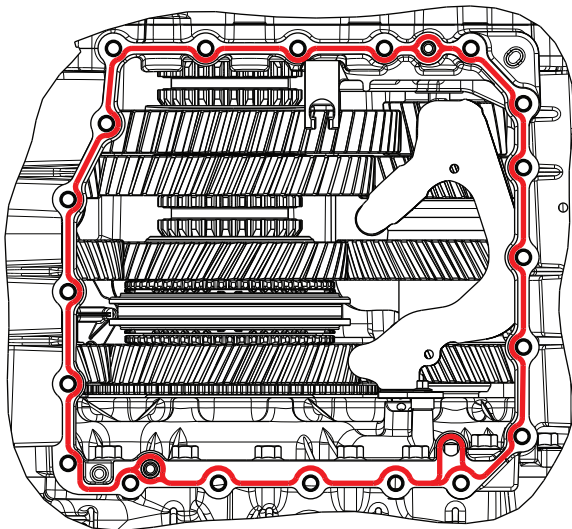

21. Install MTM onto the transmission housing. Align Rail E in the MTM with the Rail E Shift Rail in the Main Housing.

CAUTION: MTM weighs approximately 40 lbs. Keep fingers clear of pinch point between MTM and other surfaces. Dropping MTM could result in component damage and/or personal injury.

NOTICE: If the MTM is installed on the transmission and Rail E in the MTM is not aligned with Rail E in the Main Housing, Fault Code 320 (SPN 5942) sets Active and the transmission will not shift out of neutral.

22. Install 20 MTM cap screws and torque to 44.5-51.5 Nm (33-38 lb-ft) in a criss-cross pattern.

Note: 13 mm (x18), 15 mm (x2) cap screws.



Remove the Linear Clutch Actuator (LCA)

1. Loosen the 4 LCA cap screws 1-2 turns each with a T45 Torx.

NOTICE: Ensure key is off, 20-Way TCM Vehicle and Body Harness Connectors are disconnected, and 5 minutes has passed prior to LCA removal.

Note: Residual air pressure in the LCA cylinder exhausts between the LCA and MTM housing when the cap screws are loosened.



2. Remove the 4 LCA cap screws
3. Remove the LCA from the MTM.

Note: LCA piston rod end is seated in the release yoke socket; pull to release rod end from socket.



4. Inspect the plastic socket insert in the release yoke through the LCA opening using a flashlight to verify none of the fingers are missing or damaged.

Note: If the plastic insert is damaged, replace the release yoke assembly.

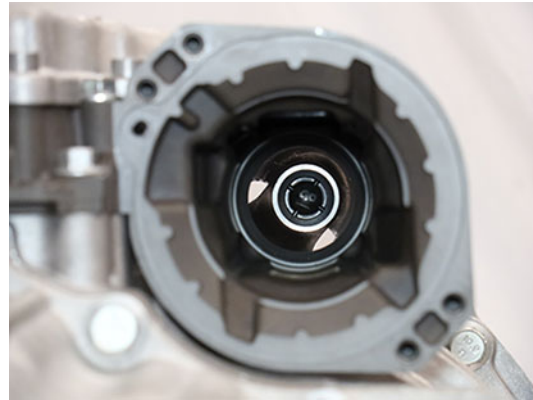

Reset and Install Linear Clutch Actuator (LCA)

1. Inspect LCA to determine next steps, reference images below:
 - If LCA is locked in the reset position, go to Install Linear Clutch Actuator (LCA).
 - If LCA is not locked in the reset position, go to Step 2.

Locked in Reset Position

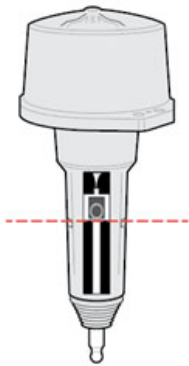

Not Locked in Reset Position

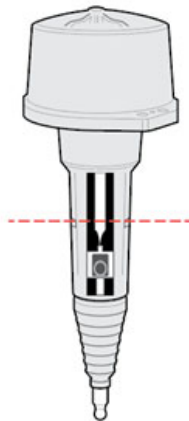

3. Inspect LCA to determine next steps, reference images below:
 - If LCA remains locked in the reset position, go to Step 4.
 - If LCA does not remain locked in the reset position, go to Step 2, repeat reset procedure.

Note: If LCA cannot be locked into the reset position, replace LCA.

CAUTION: Do not drop LCA. Dropping LCA may cause the LCA to unlock resulting in personal injury and/or component damage.

Locked in Reset Position

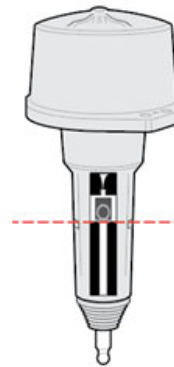

Not Locked in Reset Position

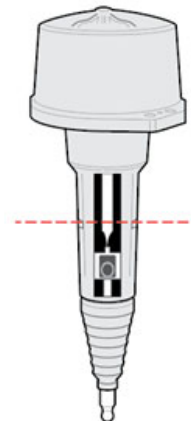

2. Place LCA push rod on a clean, flat surface. Tightly grasp LCA housing with both hands and push down on push rod to lock LCA into the reset position.



CAUTION: A large amount of force is required to lock the LCA into the reset position. Failure to tightly grasp the LCA housing with both hands while pushing down on push rod may cause unintended movement resulting in personal injury and/or component damage.



4. Clean all sealing surfaces on the MTM and LCA with a lint free cloth.

NOTICE: Do not use abrasive scrapers or powered tools to clean sealing surfaces or sealing surfaces may be damaged and leak.

5. Insert the LCA into the MTM.



6. Install 4 LCA T45 cap screws and torque to 23-28 Nm (17-21 lb-ft) in a criss-cross pattern.

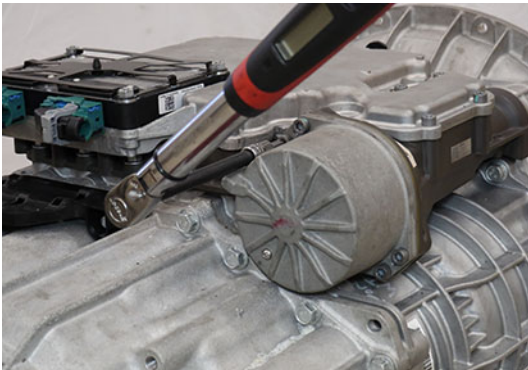

Install the Release Bearing and Clutch Release Yoke

1. Install the upper Release Yoke socket over the rod end of the Linear Clutch Actuator (LCA) and press until attached.



2. Install the lower Release Yoke socket over the lower pivot on the clutch housing and press until attached.



3. Slide the Release Bearing over the input shaft and into the Release Yoke.



Install the Transmission Control Module (TCM)

NOTICE: Do not allow contamination into the connectors on the TCM or MTM.

Note: TCM can be installed with transmission in-vehicle.

1. Install the TCM Seal on the 74-Way Harness Connector.



2. Align the TCM to the 74-Way Harness Connector and TCM studs, then install the TCM.

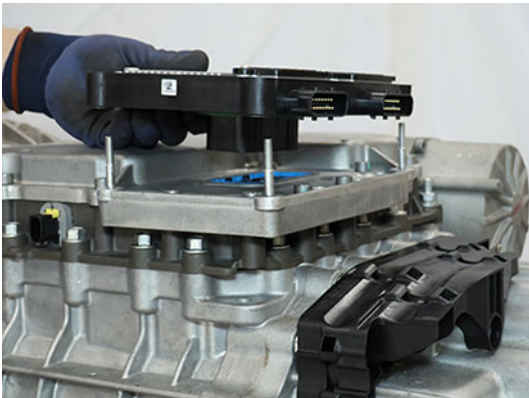

3. Torque the TCM 7 mm Jackscrew to 3.0-4.0 Nm (26.6-35.4 lb-in).

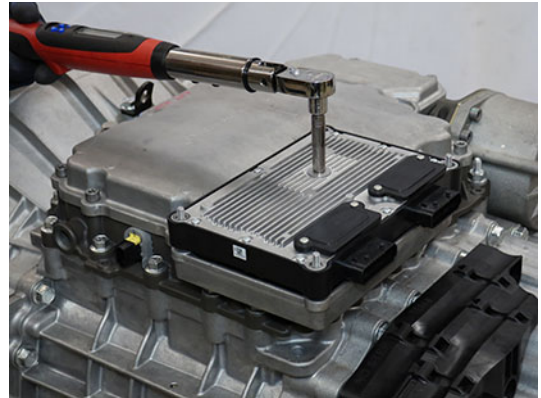

4. Install the TCM Cover over the 4 TCM studs and torque the 4 TCM Cover Nuts to 8.8-10.4 Nm (78-92 lb-in) in a criss-cross pattern.

Note: TCM Cover nuts are 10 or 13 mm.

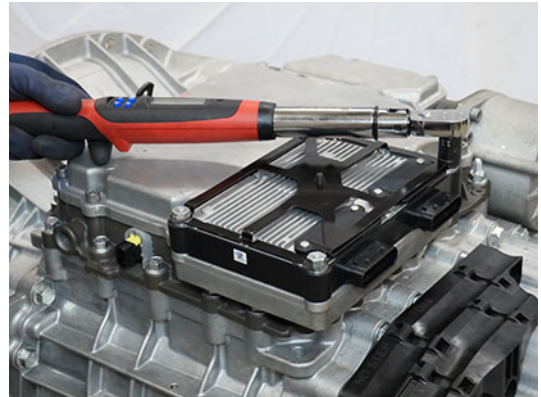

Install the Transmission

1. Refer to OEM guidelines for transmission installation.
2. Connect negative battery cable.

Fill Oil

Note: Perform the transmission fill procedure with transmission installed in vehicle to ensure proper transmission angle.

1. Remove the Oil Fill Plug with a 6 mm hex key.

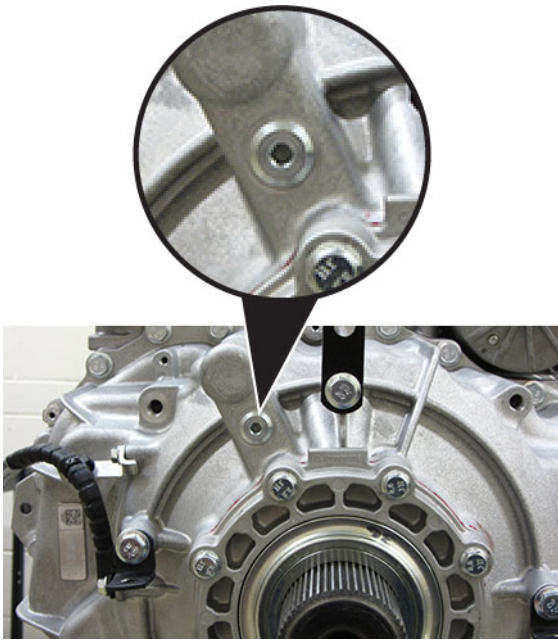

2. Place a suitable container under the Oil Check Plug and remove the Oil Check Plug with a 6 mm hex key.



3. Fill the transmission with PS-386 lube until a small amount of oil runs out of the Oil Check Plug hole.

Note: Fill capacity is approximately 7.5-8.5 liters (16-18 pints) depending on the transmission angle.

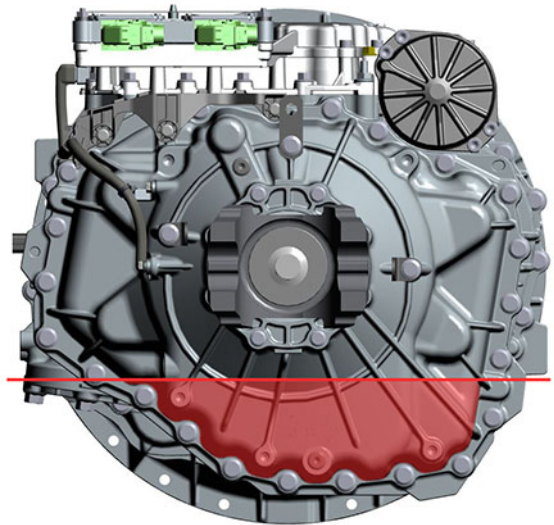
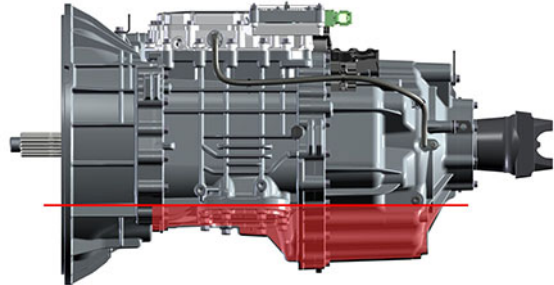

4. Inspect Oil Check Plug and O-ring for damage. If damaged, replace the Oil Check Plug; O-ring is serviced with plug.

5. Install the Oil Check Plug (6 mm) and torque to 24.5-29.5 Nm (18-22 lb-ft).

NOTICE: Do not over-torque the Oil Fill Plug or transmission damage may occur.



6. Inspect Oil Fill Plug and O-ring for damage. If damaged, replace the Oil Fill Plug; O-ring is serviced with plug.
7. Install the Oil Fill Plug (6 mm) and torque to 24.5-29.5 Nm (18-22 lb-ft).

NOTICE: Do not over-torque the Oil Fill Plug or transmission damage may occur.

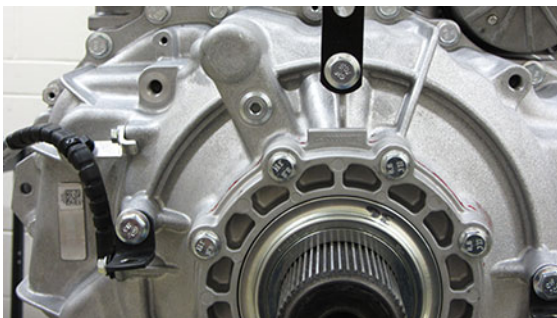

Clutch and Rail Calibration

To ensure proper operation, the TCM, clutch, MTM and transmission require a Clutch and Rail Calibration. Calibrations are automatically initiated when:

- LCA is in the reset position
- Transmission in “N” (Neutral)
- Key on engine running
- Vehicle air system pressure at operating range

NOTICE: Do not use service tool to initiate calibrations. Allow calibrations to automatically initiate.

Note: Vehicle display may indicate a flashing “CC” and “F” in gear display.

1. Set vehicle parking brake and chock wheels.
2. Ensure the driveline is connected between the transmission and axle.

Note: Clutch and Rail Calibrations cannot complete if the transmission output shaft is allowed to rotate.
3. Key on with engine running.
4. Allow vehicle air pressure to build to governor cut-off.

Note: Clutch and Rail Calibrations automatically initiate when vehicle air pressure reaches approximately 100 psi.
5. Ensure “N” (Neutral) is selected and engine is running. Wait approximately 2 minutes for calibrations to complete.

NOTICE: If process is interrupted, key off, wait 1 minute and go to Step 2.

- If vehicle display indicates a solid “N: (Neutral) in gear display, calibrations are complete. Key off, go to Step 6.
 - If vehicle display continues to indicate a flashing “CC” and/or “F” in gear display or service transmission message, go to Step 5.
6. Key off and wait 1 minute.
 7. Key on with engine off.
 8. Connect ServiceRanger.

9. Go to “Fault Codes”.
 - If an Active transmission fault code is set, go to Endurant HD Troubleshooting Guide TRTS0950 **Diagnostic Procedure**.
 - If no Active transmission fault codes are set, select “Clear Eaton Faults” and follow on-screen prompts. Go to Step 9.
10. Disconnect ServiceRanger.
11. Key off.
12. Inspect transmission for a PTO.
 - If not PTO-equipped, process complete.
 - If PTO-equipped, start the engine and run for 1 to 2 minutes to fill the PTO with oil, key off and repeat the Fill Oil Procedure.



CAUTION: Failure to repeat the Fill Oil service procedure to verify proper transmission oil level when equipped with a PTO may result in low transmission oil and component damage.

4-Bolt PTO Cover

Special Instructions

Only equipped with a Dual PTO Endurant HD transmission.

The 4-Bolt PTO Cover can be removed and installed with the transmission in-vehicle.

Special Tools

None

Component Identification

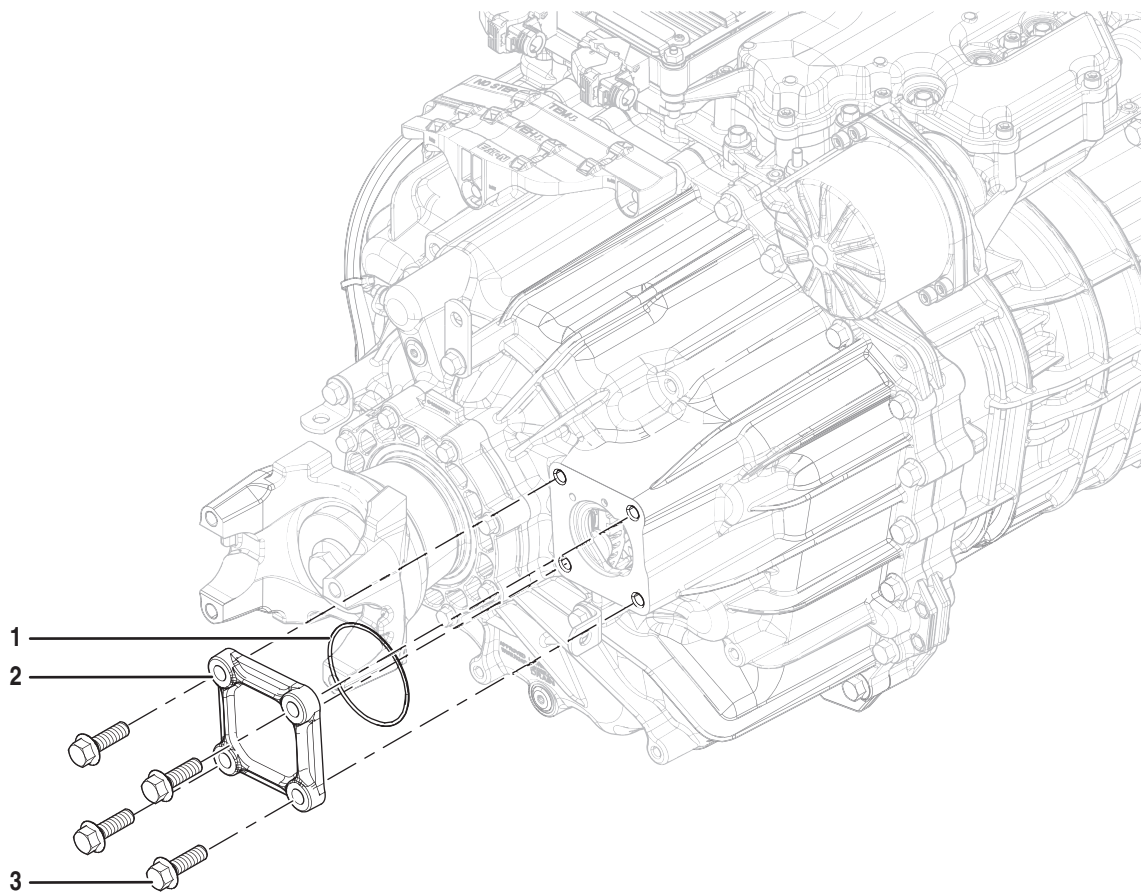

1. O-ring
2. 4-Bolt PTO Cover
3. Cap Screws (x4) - 18 mm

Remove the 4-Bolt PTO Cover

1. Remove 4 Rear PTO Cover 18 mm cap screws.



2. Using a soft-faced hammer at the 3 o'clock position, lightly tap to separate the PTO cover from the Rear Housing.



CAUTION: Keep fingers clear to avoid personal injury.



Install the 4-Bolt PTO Cover

1. Clean sealing surfaces on the rear housing and 4-Bolt PTO Cover.

NOTICE: Do not use abrasive scrapers or powered tools to clean sealing surfaces or sealing surfaces may be damaged and leak.

2. Inspect threaded bolt holes for debris and clean if necessary.

NOTICE: Ensure there is nothing in the threaded bolt holes or the transmission may be damaged when cap screws are tightened.

3. Insert a new 4-Bolt PTO Cover O-ring into groove until fully seated.

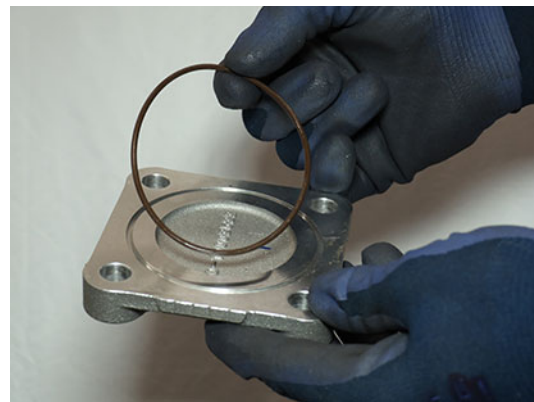

4. Install the 4-Bolt PTO Cover onto Rear Housing with 4 18 mm cap screws and torque to 69-81 Nm (51-60 lb-ft) in a criss-cross pattern.

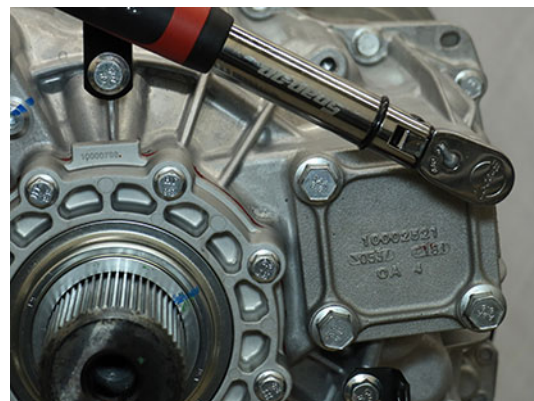

8-Bolt PTO Cover

Special Instructions

The 8-Bolt PTO Cover can be removed and installed with the transmission in-vehicle.

Special Tools

- Gasket Sealant (Loctite 5188)
- Plastic Scraper
- Non-Chlorinated Brake Cleaner (Gasket Remover)



DANGER: Do not handle non-chlorinated brake cleaner until all manufacturer precautions have been read and understood. Failure to follow precautions will result in serious personal injury or death.



CAUTION: Avoid contact between non-chlorinated brake cleaner and the transmission plastic components, electrical wiring and connectors. Failure to avoid contact will result in transmission component damage.

Component Identification

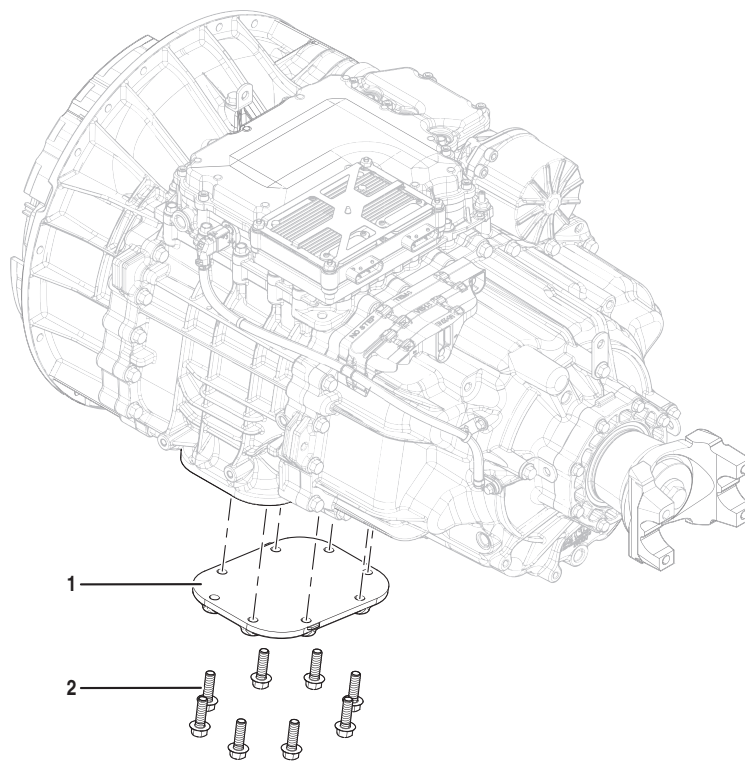

1. 8-Bolt PTO Cover
2. PTO Cover Cap Screws (x8) - 18 mm

Drain Oil

1. Locate the Oil Drain Plug on the back of the rear housing.
2. Place a suitable container under the Oil Drain Plug.
Note: If reusing oil, use a clean container free of contamination and debris.
3. Remove the Oil Drain Plug with a 6 mm hex key and drain the oil.



4. If PTO-equipped, remove PTO and drain the oil.
5. Inspect Oil Drain Plug and O-ring for damage. If damaged, replace the Oil Drain Plug; O-ring is serviced with plug.
6. Install the Oil Drain Plug (6 mm) and torque to 24.5-29.5 Nm (18-22 lb-ft).

NOTICE: Do not over-torque drain plug or transmission damage may occur.

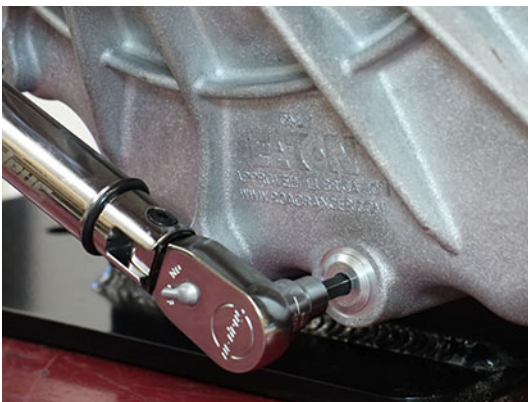

Remove the 8-Bolt PTO Cover

1. Remove 8 PTO Cover 18 mm cap screws.



2. Separate 8-Bolt PTO Cover from Main Housing at the 2 pry points.

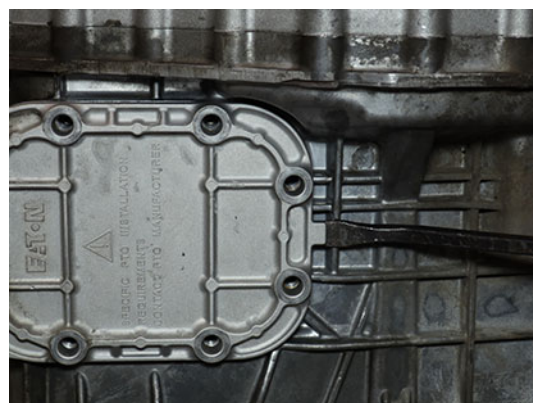
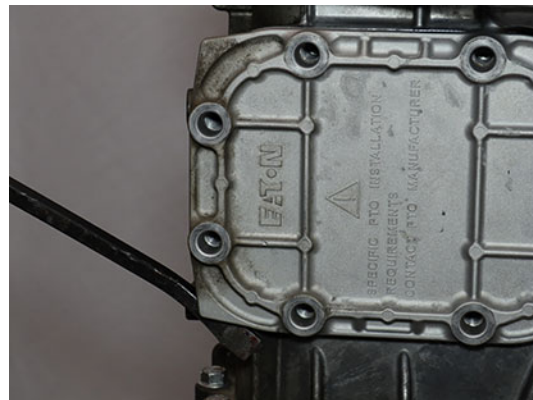

Install the 8-Bolt PTO Cover

1. Clean the sealing surface on the transmission and 8-Bolt PTO cover with gasket remover and a plastic scraper. Let air dry then wipe with a clean dry cloth.

NOTICE: Do not use abrasive scrapers or powered tools to clean sealing surfaces or sealing surfaces may be damaged and leak.

2. Inspect threaded bolt holes for debris and clean if necessary.

NOTICE: Ensure there is nothing in the threaded bolt holes or the transmission may be damaged when cap screws are tightened.

3. Apply Gasket Sealant with a bead width of 1.4-2.4 mm (0.055-0.094 inch) to Main Housing as shown in pattern below.

NOTICE: Ensure there is nothing in the threaded bolt holes or the transmission may be damaged when cap screws are tightened.

Note: Parts must be assembled within 10 minutes of applying Gasket Sealant.

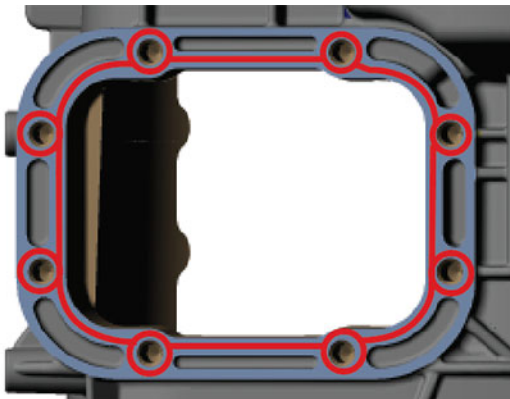

4. Install the 8-Bolt PTO Cover onto Main Housing with 8 18 mm cap screws and torque to 69-81 Nm (51-60 lb-ft) in a criss-cross pattern.

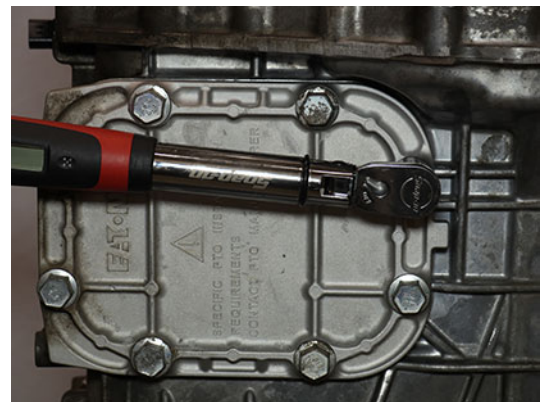
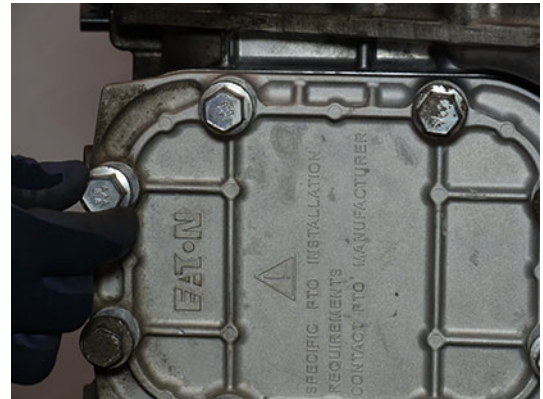

Fill Oil

Note: Perform the transmission fill procedure with transmission installed in vehicle to ensure proper transmission angle.

1. Remove the Oil Fill Plug with a 6 mm hex key.

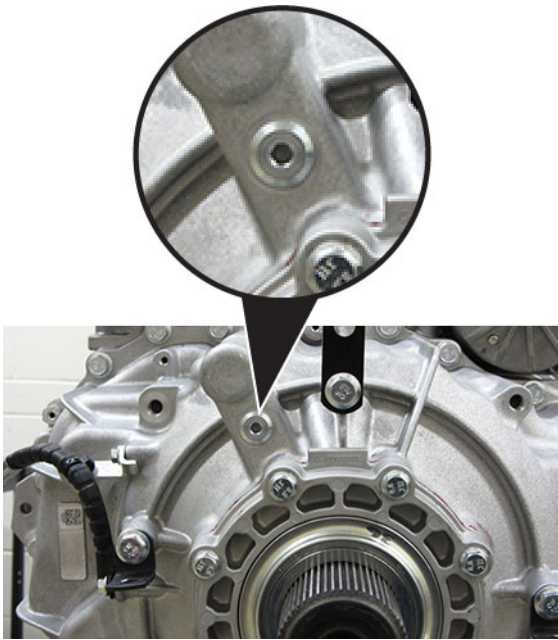

2. Place a suitable container under the Oil Check Plug and remove the Oil Check Plug with a 6 mm hex key.



3. Fill the transmission with PS-386 lube until a small amount of oil runs out of the Oil Check Plug hole.

Note: Fill capacity is approximately 7.5-8.5 liters (16-18 pints) depending on the transmission angle.

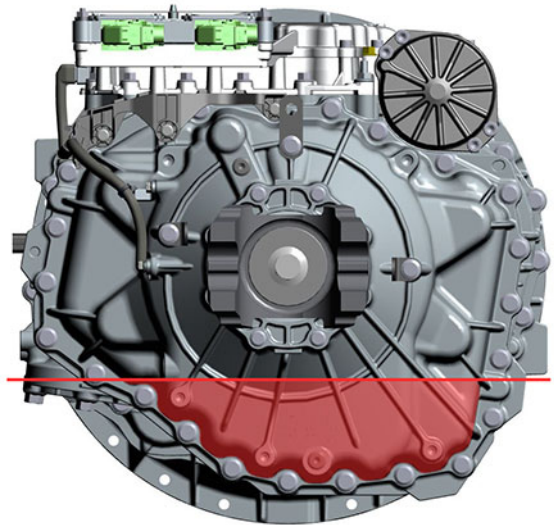
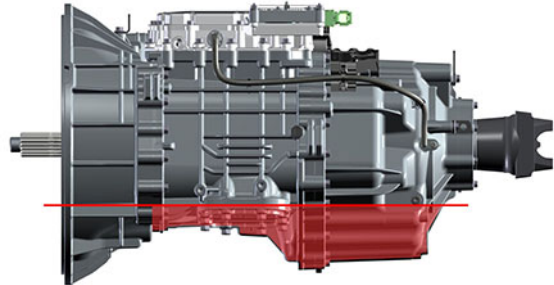

4. Inspect Oil Check Plug and O-ring for damage. If damaged, replace the Oil Check Plug; O-ring is serviced with plug.

5. Install the Oil Check Plug (6 mm) and torque to 24.5-29.5 Nm (18-22 lb-ft).

NOTICE: Do not over-torque the Oil Fill Plug or transmission damage may occur.



6. Inspect Oil Fill Plug and O-ring for damage. If damaged, replace the Oil Fill Plug; O-ring is serviced with plug.
7. Install the Oil Fill Plug (6 mm) and torque to 24.5-29.5 Nm (18-22 lb-ft).

NOTICE: Do not over-torque the Oil Fill Plug or transmission damage may occur.

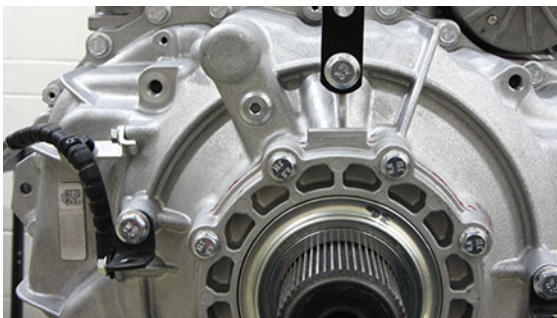

8. Inspect transmission for a PTO.
 - If not PTO-equipped, process complete.
 - If PTO-equipped, start the engine and run for 1 to 2 minutes to fill the PTO with oil, key off and repeat the Fill Oil Procedure.



CAUTION: Failure to repeat the Fill Oil service procedure to verify proper transmission oil level when equipped with a PTO may result in low transmission oil and component damage.

Oil Pump Assembly

Special Instructions



WARNING: Rear Housing Assembly weighs approximately 170 lbs. Failure to properly secure and lift the Rear Housing Assembly may result in major vehicle component damage, severe injury or death.

Special Tools

- Rear Housing Alignment Pins (RR1090TR)
- Gasket Sealant (Loctite 5188)
- Plastic Scraper
- Non-Chlorinated Brake Cleaner (Gasket Remover)



DANGER: Do not handle non-chlorinated brake cleaner until all manufacturer precautions have been read and understood. Failure to follow precautions will result in serious personal injury or death.



CAUTION: Avoid contact between non-chlorinated brake cleaner and the transmission plastic components, electrical wiring and connectors. Failure to avoid contact will result in transmission component damage.

Component Identification

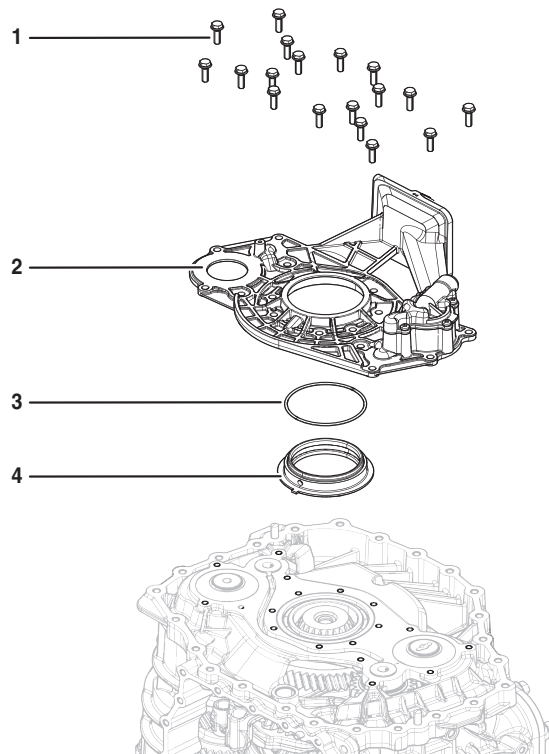

1. Oil Pump Assembly Cap Screws (x18) - 13 mm
2. Oil Pump Assembly

3. O-ring
4. Oil Pump/Range Spacer

Create a Service Activity Report

Note: If not already created and sent.

1. Key on with engine off.
2. Connect ServiceRanger and create a Service Activity Report.
3. Select "Send to Eaton" (internet connection required)
4. Disconnect ServiceRanger.
5. Key off.

Manually Vent Linear Clutch Actuator (LCA)

1. Key off.
2. Set vehicle parking brake and chock wheels.

! **WARNING:** Apply vehicle parking brake and follow vehicle manufacture parking instructions. Failure to follow these instructions could cause unintended vehicle movement and may result in major vehicle component damage, severe injury or death.

3. Loosen the 4 Linear Clutch Actuator (LCA) cap screws 1-2 turns each with a T45 Torx.

Note: Residual air pressure in the LCA cylinder exhausts between the LCA and Mechatronic Transmission Module (MTM) housing when the cap screws are loosened.

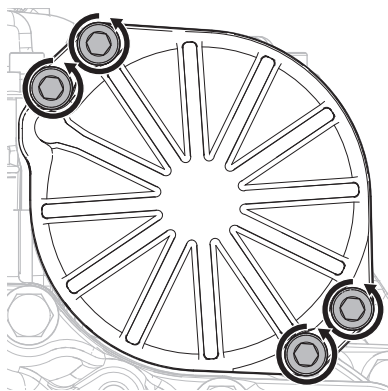

4. Tighten the 4 LCA to MTM T45 cap screws and torque to 23-27 Nm (17-21 lb-ft).

Drain Oil

1. Locate the Oil Drain Plug on the back of the rear housing.
2. Place a suitable container under the Oil Drain Plug.

Note: If reusing oil, use a clean container free of contamination and debris.

3. Remove the Oil Drain Plug with a 6 mm hex key and drain the oil.



4. If PTO-equipped, remove PTO and drain the oil.
5. Inspect Oil Drain Plug and O-ring for damage. If damaged, replace the Oil Drain Plug; O-ring is serviced with plug.
6. Install the Oil Drain Plug (6 mm) and torque to 24.5-29.5 Nm (18-22 lb-ft).

NOTICE: Do not over-torque drain plug or transmission damage may occur.

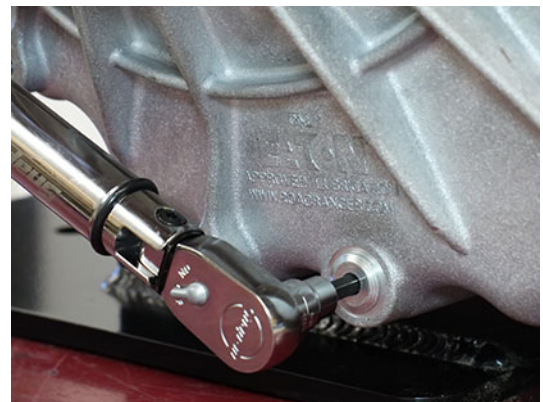

Remove the Transmission

1. Disconnect negative battery cable.
2. Refer to OEM guidelines for transmission removal.

Remove the Transmission Control Module (TCM)

1. Unscrew the 4 TCM Cover nuts and remove TCM Cover.

Note: TCM Cover nuts are 10 or 13 mm.



2. Unscrew the TCM 7 mm Jackscrew. Lift and remove the TCM from the MTM.

NOTICE: Do not allow contamination into the connectors on the TCM or MTM.



3. Inspect the TCM Seal for damage.

NOTICE: Replace the TCM Seal if damaged.

Note: If replacing the TCM, the REMAN TCM includes a new seal.



Remove the Release Bearing and Clutch Release Yoke

1. Remove the Release Bearing by sliding the bearing off the input shaft.



2. Pull to free the lower Clutch Release Yoke socket from the lower pivot on the clutch housing.

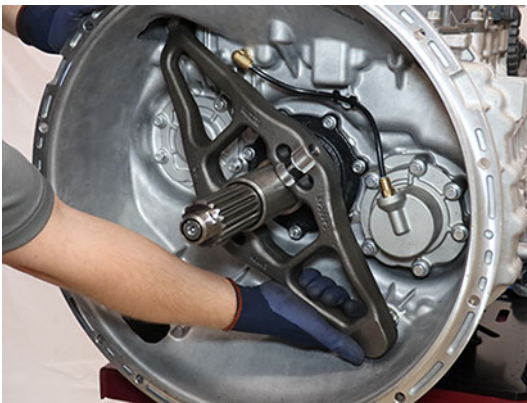

3. Pull to free the upper Clutch Release Yoke socket from the Linear Clutch Actuator (LCA) rod end.



4. Inspect the plastic socket inserts in the Clutch Release Yoke to verify none of the fingers are missing or damaged.

Note: If the plastic insert is damaged, replace the Clutch Release Yoke assembly.



Remove the Mechatronic Transmission Module (MTM)

1. Lift the latch on the Output Speed Sensor Harness at the Connector on the Mechatronic Transmission Module (MTM).

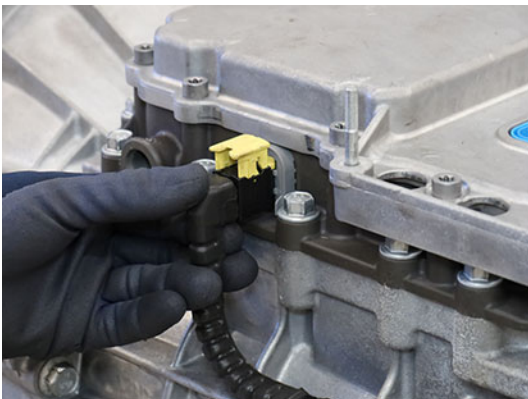

2. Remove the Output Speed Sensor Harness from the Connector on the MTM.



3. Remove the 20 MTM cap screws.

Note: 13 mm (x18), 15 mm (x2).



4. Separate the MTM from the Main Housing at the 2 pry points.

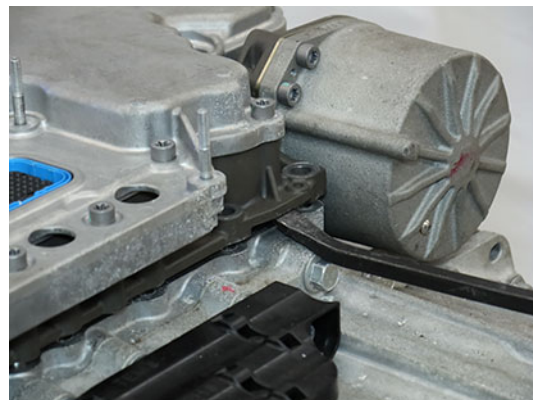

5. Remove the MTM from the transmission housing.

⚠ CAUTION: MTM weighs approximately 40 lbs. Keep fingers clear of pinch point between MTM and other surfaces. Dropping MTM could result in component damage and/or personal injury.



Remove the Output Speed Sensor

1. Remove the Output Speed Sensor Harness tie strap at the Harness Bracket.



2. Remove the 2 harness press-in retainers from the Main Housing and bracket on Rear Housing.



3. Remove the Output Speed Sensor 10 mm cap screw.



4. Remove the Output Speed Sensor from the Rear Housing.

Note: The sensor may need to be twisted and pulled from the bore.

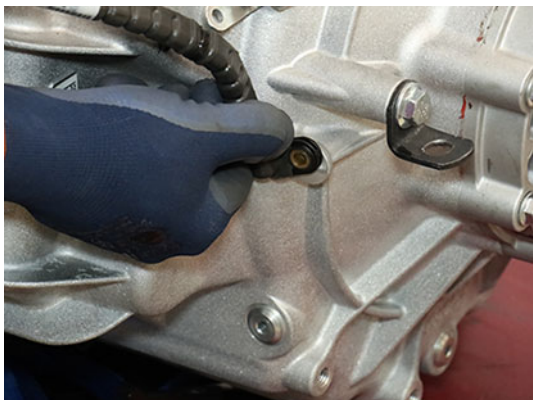

Remove the Harness Bracket

Note: This procedure contains removing the Harness Bracket without the Mechatronic Transmission Module (MTM).

1. Remove 3 Harness Bracket 10 mm cap screws.



2. Remove Harness Bracket.



Secure Transmission (Vertical)

1. Place transmission in the vertical position with the front side down.



WARNING: Transmission weighs approximately 550 lbs. Keep fingers clear of pinch point between transmission and other surfaces. Dropping transmission may result in major vehicle component damage, severe injury or death.

NOTICE: Use an appropriate lifting device to safely lift component.

Note: Use a surface with an opening that allows the input shaft to pass through and the clutch housing to sit flat and secure.

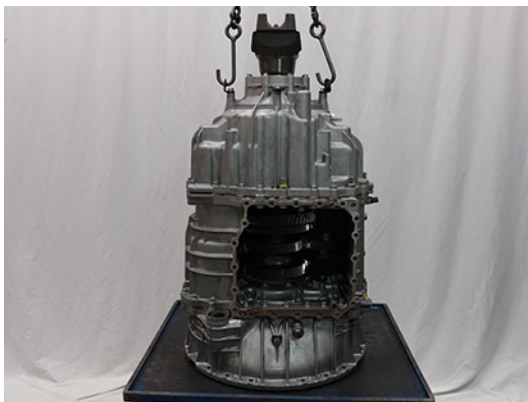
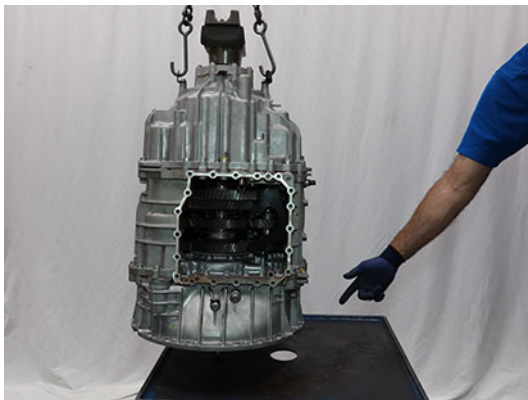

Remove the Rear Housing

1. At the 3 Rear Housing Threaded cap screws, apply paint marks on the Rear Housing to identify location.



2. Remove 21 Rear Housing and 3 threaded 16 mm cap screws.



3. Install and hand tighten 2 Rear Housing Alignment Pins (RR1090TR) 180-degrees apart.

NOTICE: Failure to install alignment pins results in transmission component damage.



4. Separate the Rear Housing from the Main Housing at the 2 pry points.



5. Lift and remove Rear Housing Assembly from Main Housing.



WARNING: Rear Housing Assembly weighs approximately 170 lbs. Failure to properly secure and lift the Rear Housing Assembly may result in major vehicle component damage, severe injury or death.

NOTICE: Use an appropriate lifting device to safely lift component.

Note: Dual PTO Transmissions are equipped with a rear PTO lube tube port on the pump and rear PTO drive splines on the Upper Countershaft.

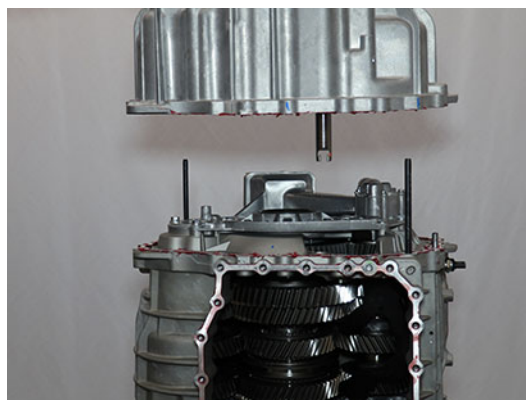

- Place Rear Housing Assembly on bench.



WARNING: Rear Housing Assembly weighs approximately 170 lbs. Keep fingers clear of pinch point between Rear Housing Assembly and other surfaces. Dropping Rear Housing may result in major vehicle component damage, severe injury or death.

NOTICE: Support the Rear Housing Assembly to prevent damage to Shift Rail E.



- Remove the 2 Rear Housing Alignment Pins (RR1090TR) from the Main Housing.

Remove the Oil Pump Assembly

- Remove 18 Oil Pump Assembly 13 mm cap screws.



- Remove Oil Pump Assembly.



- Remove Oil Pump/Range Spacer with O-ring.



Install the Oil Pump Assembly

1. Install O-ring to the Oil Pump/Range Spacer.



2. Install Oil Pump/Range Spacer with O-ring and align tab with groove in Oil Pump Assembly.

NOTICE: Ensure the spacer tab is aligned with the groove and the spacer sits flush in the Oil Pump Assembly.



3. While holding the Oil Pump/Range Spacer in place, align oil pump drive key with slot on Lower Counter-shaft and install Oil Pump Assembly to Main Housing.



CAUTION: Failure to properly install the Oil Pump/Range Spacer and align the oil pump drive key results in transmission component damage during Oil Pump Assembly installation.

NOTICE: Ensure oil pump drive key is aligned with counter shaft drive slot during Oil Pump Assembly installation.



4. Press Oil Pump Assembly to ensure it sits flat on Main Housing sealing surface.



5. Install 18 Oil Pump Assembly 13 mm cap screws and torque to 21–23 Nm (16–18 lb–ft) in a criss-cross pattern.

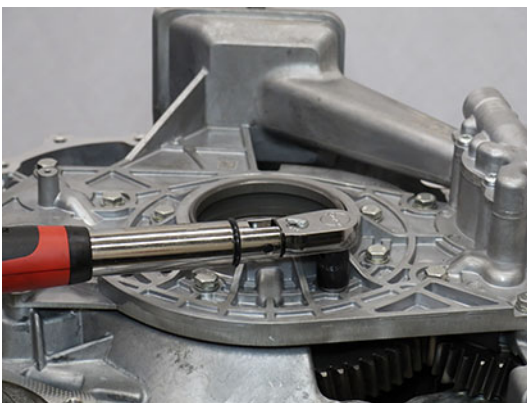

Install the Rear Housing

1. Clean the sealing surfaces on the transmission Main Housing and Rear Housing with gasket remover and a plastic scraper. Let air dry then wipe with a clean dry cloth.

NOTICE: Do not use abrasive scrapers or powered tools to clean sealing surfaces or sealing surfaces may be damaged and leak.

2. Inspect threaded bolt holes for debris and clean if necessary.
3. Apply Gasket Sealant with a bead width of 1.4-2.4 mm (0.055-0.094 inch) to the transmission Main Housing sealing surface following the pattern below.

NOTICE: Ensure there is nothing in the threaded bolt holes or the transmission housing may be damaged when cap screws are tightened.

Note: Parts must be assembled within 10 minutes of applying Gasket Sealant.

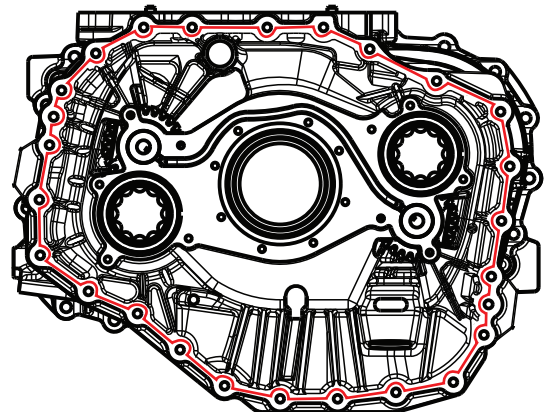

4. Install and hand tighten 2 Rear Housing Alignment Pins (RR1090TR) 180-degrees apart.



CAUTION: Failure to install alignment pins results in transmission component damage during Rear Housing Assembly installation.

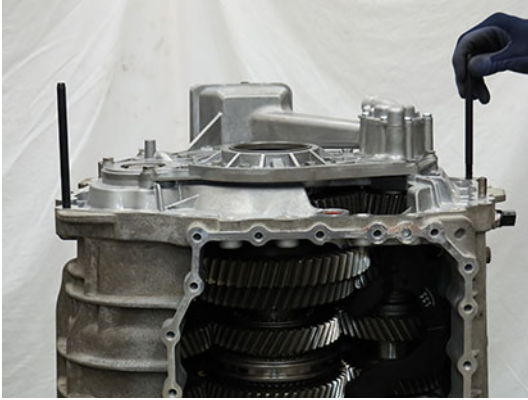

6. Install the 3 Rear Housing Threaded 16 mm cap screws at the 3 paint mark locations.

Note: Two cap screws are used to mount the harness bracket and the third is used by the OEM for additional attachment points.



5. Lift and install the Rear Housing Assembly on to the Main Housing.



WARNING: Rear Housing Assembly weighs approximately 170 lbs. Failure to properly secure and lift the Rear Housing may result in major vehicle component damage, severe injury or death.

NOTICE: Use an appropriate lifting device to safely lift component.

Note: Align the Rear Housing to the alignment pins and align Shift Rail E into the Main Housing during installation.

Note: Rotate Output Shaft to align gearing and allow Rear Housing Assembly to fully seat on Main Housing.



7. Remove the 2 Rear Housing Alignment Pins (RR1090TR).

8. Install the remaining 21 Rear Housing 16 mm cap screws and torque to 44.5 - 51.5 Nm (33-38 lb-ft) in a criss-cross pattern.

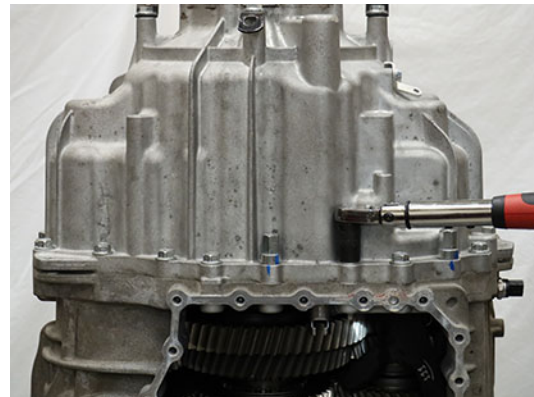

9. Lift transmission horizontally onto a bench.



WARNING: Transmission weighs approximately 550 lbs. Keep fingers clear of pinch point between transmission and other surfaces. Dropping transmission may result in major vehicle component damage, severe injury or death.

NOTICE: Use an appropriate lifting device to safely lift component.

Install the Harness Bracket

Note: This procedure contains installing the Harness Bracket without the Mechatronic Transmission Module (MTM).

1. Install Harness Bracket.



2. Install 3 Harness Bracket 10 mm cap screws and torque to 8.8 - 10.4 Nm (6-8 lb-ft).



Install the Output Speed Sensor

1. Clean the sensor bore.

NOTICE: Do not use abrasive scrapers or powered tools to clean sealing surface.

2. Apply a light coat of transmission oil to the sensor O-ring.
3. Install the Output Speed Sensor into the bore.

Note: The Sensor may need to be twisted and pushed into the bore.



4. Install the Output Speed Sensor 10 mm cap screw and torque to 8.8-10.4 Nm (6-8 lb-ft).



5. Press the 2 harness press-in retainers into the Main Housing and the bracket on the rear housing.

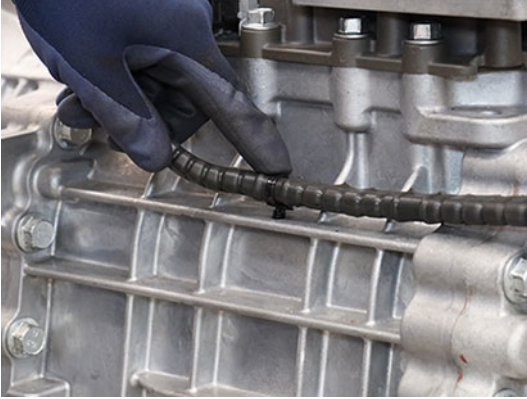

6. Secure the Output Speed Sensor Harness to the Harness Bracket with a tie strap.



CAUTION: Failure to tie strap the Output Speed Sensor Harness to the Harness Bracket may result in harness damage.

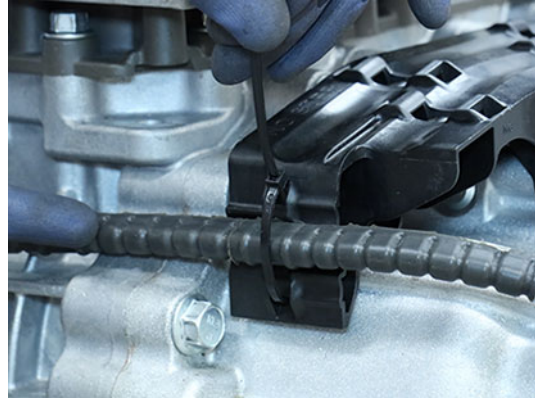

Install the Mechatronic Transmission Module (MTM)

Note: If replacing original equipment MTM with new/replacement MTM locate new/replacement MTM part information tag and record Part Number and Serial Number. Refer to Component Identification section. Part Number and Serial Number are required to properly configure TCM after MTM installation.

1. Place the transmission in a horizontal position.

NOTICE: The transmission must be in a horizontal position prior to the MTM Installation procedure. Failure to do so causes the sliding clutches to move out of neutral and not align to the shift yokes. If the shift yokes are not aligned to the sliding clutches, position sensor fault codes set Active and the transmission will not shift out of neutral.

2. Clean the sealing surfaces on the transmission and Mechatronic Transmission Module (MTM) with gasket remover and a plastic scraper. Let air dry then wipe with a clean dry cloth.

NOTICE: Do not use abrasive scrapers or powered tools to clean sealing surfaces or sealing surfaces may be damaged and leak.

3. Inspect threaded bolt holes for debris and clean if necessary.

NOTICE: Ensure there is nothing in the threaded bolt holes or the transmission may be damaged when cap screws are tightened.

4. Install the Rail B Engagement Tool (RR1088TR) to the Main Housing and hand tighten with 2 MTM cap screws.



5. Shift the Rail B Synchronizer to neutral.

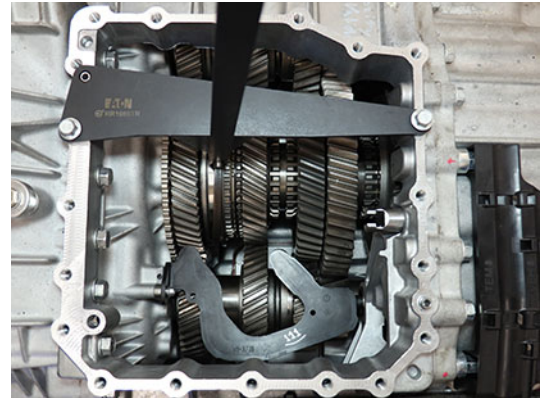

6. Remove the Rail B Engagement Tool.
7. Move Rail C and Rail D sliding clutches to neutral.

NOTICE: The transmission must be in a horizontal position prior to the MTM Installation procedure. Failure to do so causes the sliding clutches to move out of neutral and not align to the shift yokes. If the shift yokes are not aligned to the sliding clutches, position sensor fault codes set Active and the transmission will not shift out of neutral.

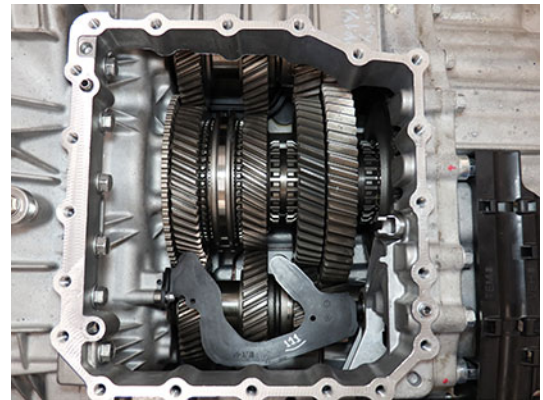

8. Install the Confirm-Neutral Gauge (RR1086TR-2) into the slots of the synchronizer and sliding clutches.

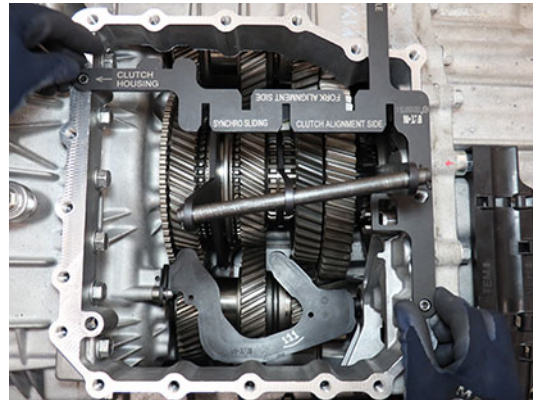
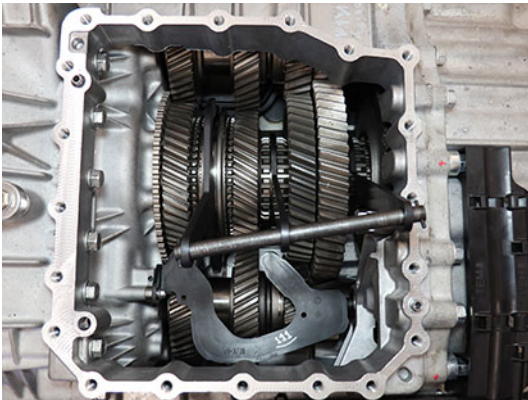

9. Install the MTM Alignment Tool (RR1086TR-1) onto the main housing.

10. Verify synchronizer and sliding clutches are in neutral by sliding Confirm-Neutral Gauge into the slots of MTM Alignment Tool.

Note: If the gauge does not slide into the alignment tool slots, neutral is not achieved. Go to Step 4.

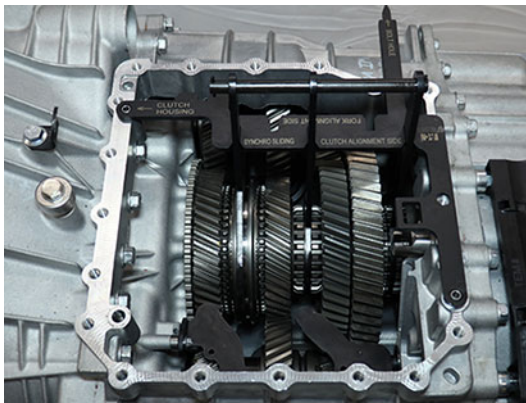

11. Using the Rail E Lever, move Rail E to neutral.

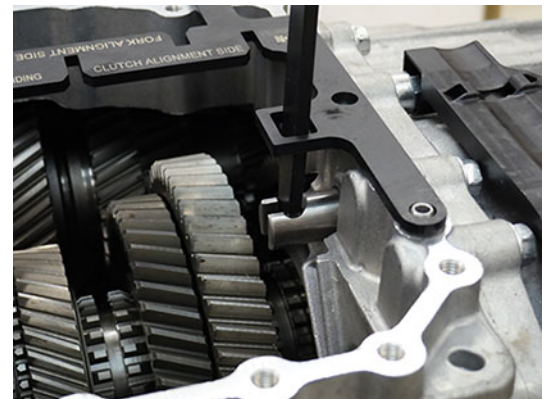
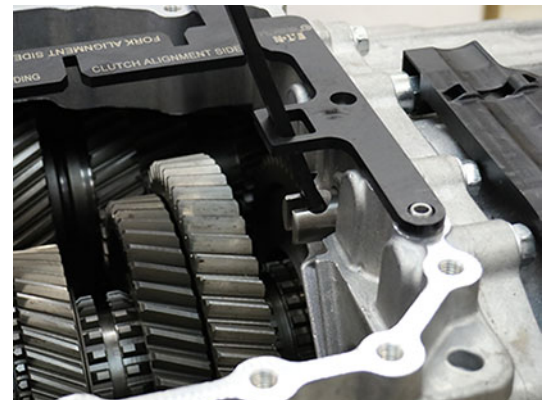
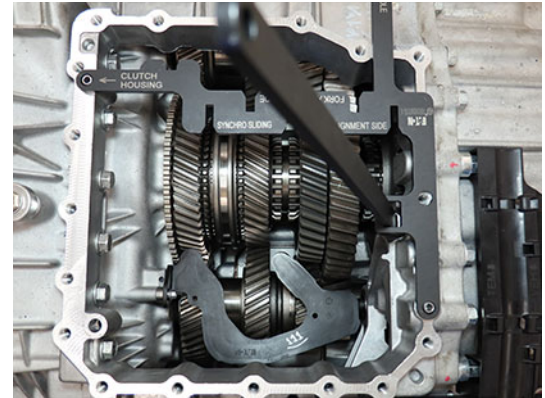

12. Verify Rail E is in neutral using the Gear Side Actuator end of the Confirm-Neutral Gauge (RR1088TR-2) at Shift Rail E. Rail E is in neutral when end of gauge rests against housing with rail against notch-end of gauge.

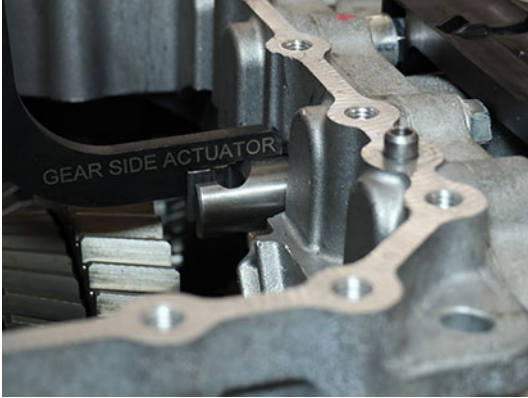

13. Move Shift Rail B in the MTM to neutral. Rail B is in neutral when the ball detent is in the notch of the Rail B yoke assembly.

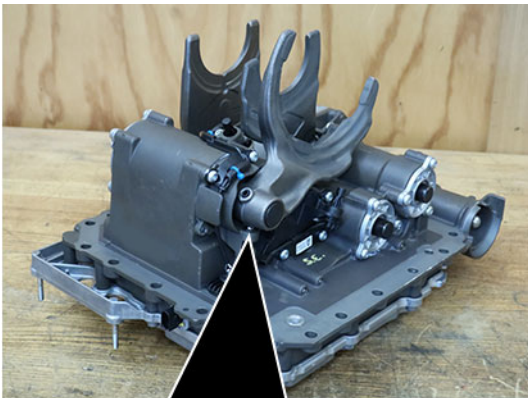

14. Move Shift Rails C and D in the MTM to neutral. Rails C and D are in neutral when the shift inter-lock is aligned with the notches of the rail yoke assemblies.

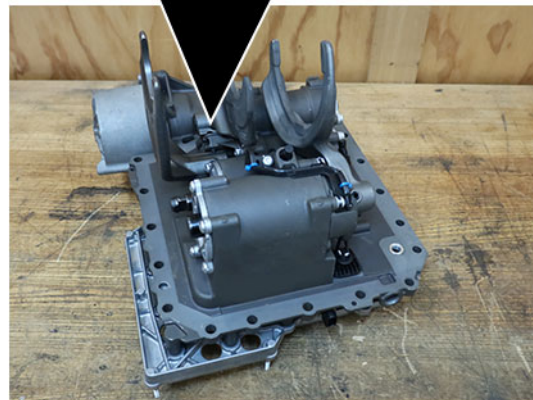

- Verify MTM is in neutral. Install the MTM Alignment Tool (RR1086TR-1) into the bolt hole and onto Rail B, C, and D Shift Yokes.

Note: If the MTM Alignment Tool slots do not align with the 3 shift yokes, neutral has not been achieved. Go to Step 13.



- Verify Rail E is in neutral using the Fork Side Actuator end of the Confirm-Neutral Gauge (RR1088TR-2) at Shift Rail E. Rail E is in neutral when end of gauge rests against cover with rail against notch-end of gauge.

Note: If Rail E is not in neutral, slide rail in or out until neutral is achieved.



- Verify notch on Rail E is facing up.

Note: If MTM is installed on transmission with notch on Rail E facing down, Fault Code/SPN 320/5942 sets Active and transmission does not shift out of neutral.

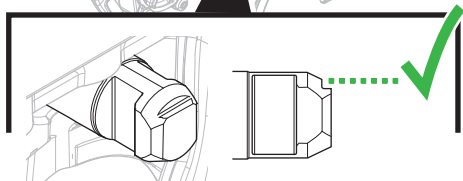
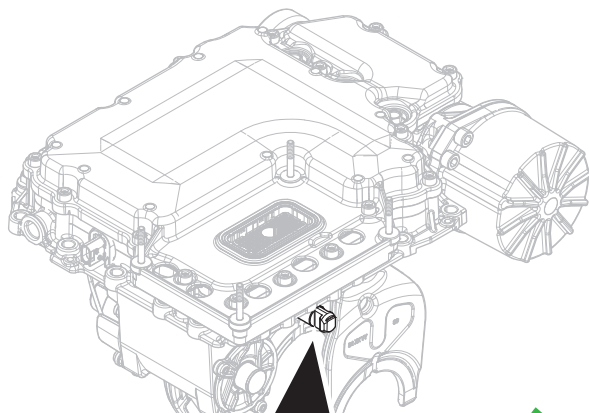

- Slide O-ring over the MTM front alignment pin on the main housing until fully seated in the groove.

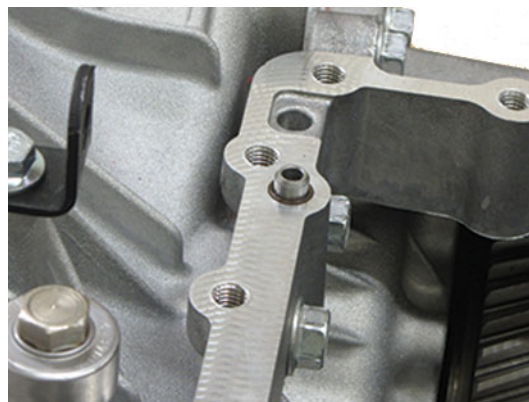

19. Clean the sealing surfaces on the transmission and Mechatronic Transmission Module (MTM) with gasket remover and a plastic scraper. Let air dry then wipe with a clean dry cloth.

NOTICE: Do not use abrasive scrapers or powered tools to clean sealing surfaces or sealing surfaces may be damaged and leak.

20. Apply gasket sealant with a bead width of 1.4-2.4mm (0.055-0.094 inch) to the transmission housing sealing surface following the pattern below.

NOTICE: Ensure there is nothing in the threaded bolt holes or the transmission may be damaged when cap screws are tightened.

Note: Parts must be assembled within 10 minutes of applying Gasket Sealant.

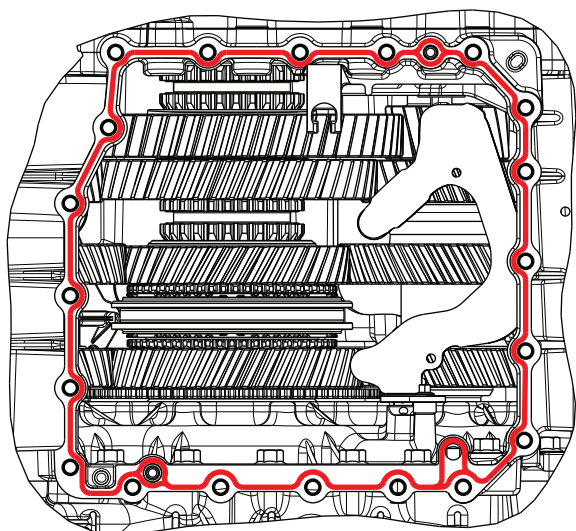

22. Install 20 MTM cap screws and torque to 44.5-51.5 Nm (33-38 lb-ft) in a criss-cross pattern.

Note: 13 mm (x18), 15 mm (x2) cap screws.

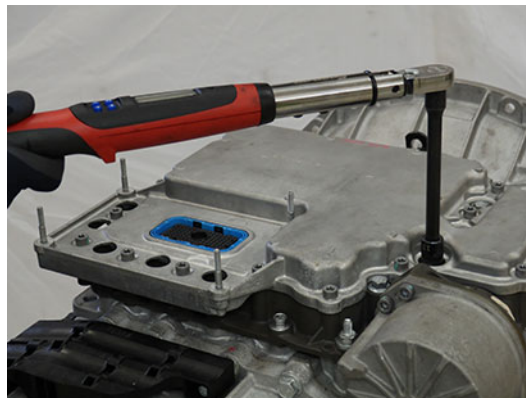

21. Install MTM onto the transmission housing. Align Rail E in the MTM with the Rail E Shift Rail in the Main Housing.

CAUTION: MTM weighs approximately 40 lbs. Keep fingers clear of pinch point between MTM and other surfaces. Dropping MTM could result in component damage and/or personal injury.

NOTICE: If the MTM is installed on the transmission and Rail E in the MTM is not aligned with Rail E in the Main Housing, Fault Code 320 (SPN 5942) sets Active and the transmission will not shift out of neutral.

Install the Transmission Control Module (TCM)

NOTICE: Do not allow contamination into the connectors on the TCM or MTM.

Note: TCM can be installed with transmission in-vehicle.

1. Install the TCM Seal on the 74-Way Harness Connector.



2. Align the TCM to the 74-Way Harness Connector and TCM studs, then install the TCM.

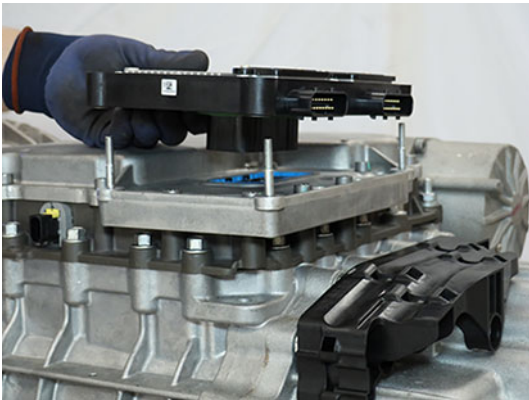

3. Torque the TCM 7 mm Jackscrew to 3.0-4.0 Nm (26.6-35.4 lb-in).

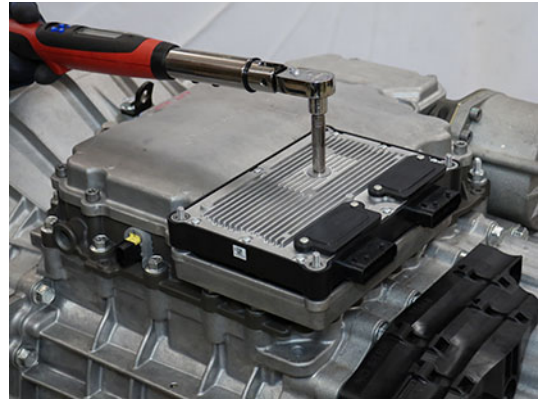

4. Install the TCM Cover over the 4 TCM studs and torque the 4 TCM Cover Nuts to 8.8-10.4 Nm (78-92 lb-in) in a criss-cross pattern.

Note: TCM Cover nuts are 10 or 13 mm.

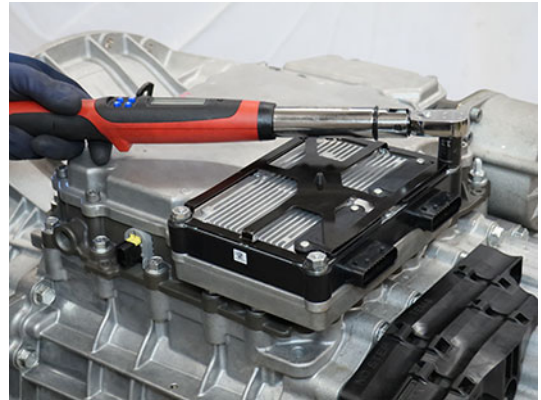

Remove the Linear Clutch Actuator (LCA)

1. Loosen the 4 LCA cap screws 1-2 turns each with a T45 Torx.

NOTICE: Ensure key is off, 20-Way TCM Vehicle and Body Harness Connectors are disconnected, and 5 minutes has passed prior to LCA removal.

Note: Residual air pressure in the LCA cylinder exhausts between the LCA and MTM housing when the cap screws are loosened.



2. Remove the 4 LCA cap screws
3. Remove the LCA from the MTM.

Note: LCA piston rod end is seated in the release yoke socket; pull to release rod end from socket.



4. Inspect the plastic socket insert in the release yoke through the LCA opening using a flashlight to verify none of the fingers are missing or damaged.

Note: If the plastic insert is damaged, replace the release yoke assembly.

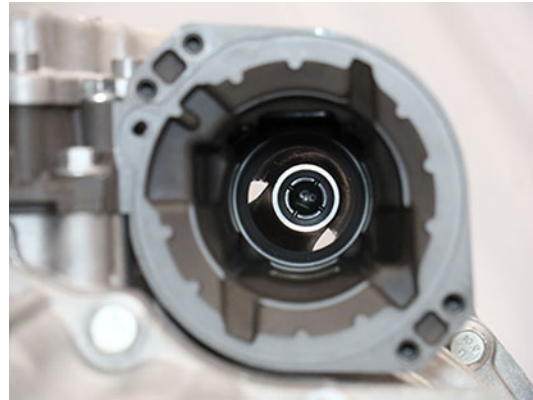

Reset and Install Linear Clutch Actuator (LCA)

1. Inspect LCA to determine next steps, reference images below:
 - If LCA is locked in the reset position, go to Install Linear Clutch Actuator (LCA).
 - If LCA is not locked in the reset position, go to Step 2.

Locked in Reset Position

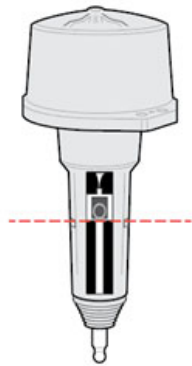

Not Locked in Reset Position

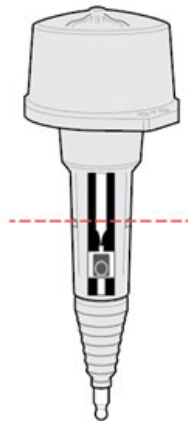

3. Inspect LCA to determine next steps, reference images below:
 - If LCA remains locked in the reset position, go to Step 4.
 - If LCA does not remain locked in the reset position, go to Step 2, repeat reset procedure.

Note: If LCA cannot be locked into the reset position, replace LCA.

CAUTION: Do not drop LCA. Dropping LCA may cause the LCA to unlock resulting in personal injury and/or component damage.

Locked in Reset Position

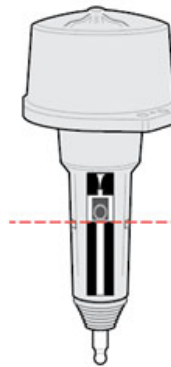

Not Locked in Reset Position

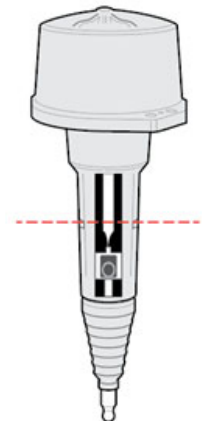

2. Place LCA push rod on a clean, flat surface. Tightly grasp LCA housing with both hands and push down on push rod to lock LCA into the reset position.



CAUTION: A large amount of force is required to lock the LCA into the reset position. Failure to tightly grasp the LCA housing with both hands while pushing down on push rod may cause unintended movement resulting in personal injury and/or component damage.



4. Clean all sealing surfaces on the MTM and LCA with a lint free cloth.

NOTICE: Do not use abrasive scrapers or powered tools to clean sealing surfaces or sealing surfaces may be damaged and leak.

5. Insert the LCA into the MTM.



6. Install 4 LCA T45 cap screws and torque to 23-28 Nm (17-21 lb-ft) in a criss-cross pattern.

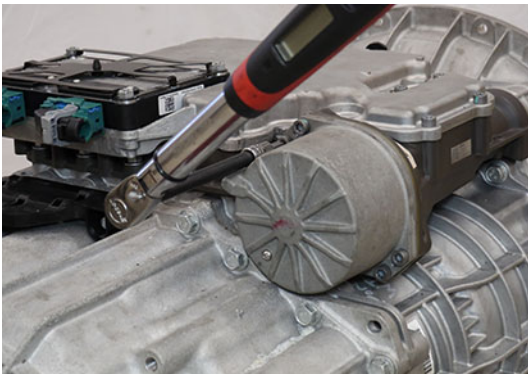

Install the Release Bearing and Clutch Release Yoke

1. Install the upper Release Yoke socket over the rod end of the Linear Clutch Actuator (LCA) and press until attached.



2. Install the lower Release Yoke socket over the lower pivot on the clutch housing and press until attached.

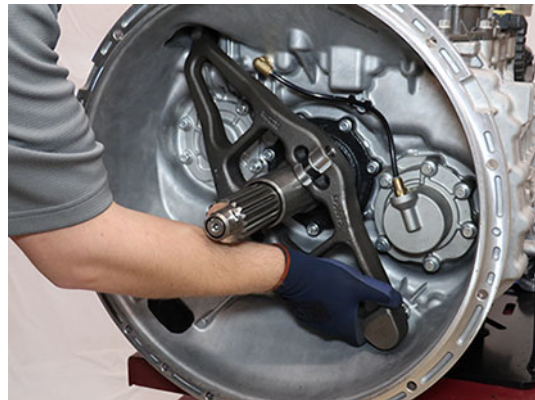

- Slide the Release Bearing over the input shaft and into the Release Yoke.



Install the Transmission

- Refer to OEM guidelines for transmission installation.
- Connect negative battery cable.

Fill Oil

Note: Perform the transmission fill procedure with transmission installed in vehicle to ensure proper transmission angle.

- Remove the Oil Fill Plug with a 6 mm hex key.

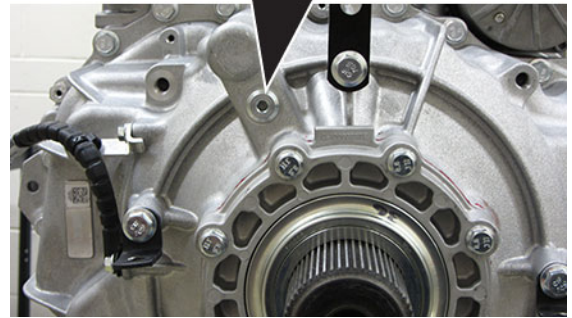

- Place a suitable container under the Oil Check Plug and remove the Oil Check Plug with a 6 mm hex key.



3. Fill the transmission with PS-386 lube until a small amount of oil runs out of the Oil Check Plug hole.

Note: Fill capacity is approximately 7.5-8.5 liters (16-18 pints) depending on the transmission angle.

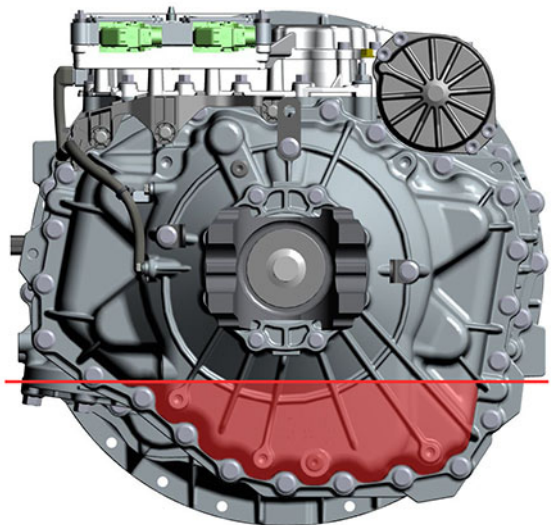
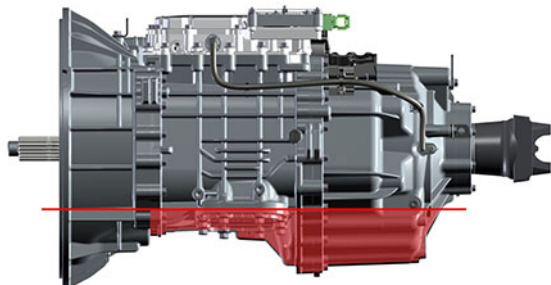

4. Inspect Oil Check Plug and O-ring for damage. If damaged, replace the Oil Check Plug; O-ring is serviced with plug.

5. Install the Oil Check Plug (6 mm) and torque to 24.5-29.5 Nm (18-22 lb-ft).

NOTICE: Do not over-torque the Oil Fill Plug or transmission damage may occur.



6. Inspect Oil Fill Plug and O-ring for damage. If damaged, replace the Oil Fill Plug; O-ring is serviced with plug.

7. Install the Oil Fill Plug (6 mm) and torque to 24.5-29.5 Nm (18-22 lb-ft).

NOTICE: Do not over-torque the Oil Fill Plug or transmission damage may occur.

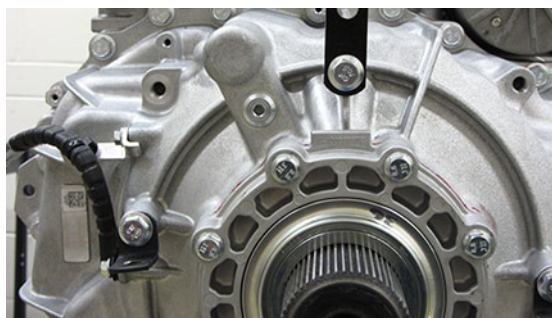

Clutch and Rail Calibration

To ensure proper operation, the TCM, clutch, MTM and transmission require a Clutch and Rail Calibration. Calibrations are automatically initiated when:

- LCA is in the reset position
- Transmission in “N” (Neutral)
- Key on engine running
- Vehicle air system pressure at operating range

NOTICE: Do not use service tool to initiate calibrations. Allow calibrations to automatically initiate.

Note: Vehicle display may indicate a flashing “CC” and “F” in gear display.

1. Set vehicle parking brake and chock wheels.
2. Ensure the driveline is connected between the transmission and axle.

Note: Clutch and Rail Calibrations cannot complete if the transmission output shaft is allowed to rotate.
3. Key on with engine running.
4. Allow vehicle air pressure to build to governor cut-off.

Note: Clutch and Rail Calibrations automatically initiate when vehicle air pressure reaches approximately 100 psi.
5. Ensure “N” (Neutral) is selected and engine is running. Wait approximately 2 minutes for calibrations to complete.

NOTICE: If process is interrupted, key off, wait 1 minute and go to Step 2.

 - If vehicle display indicates a solid “N: (Neutral) in gear display, calibrations are complete. Key off, go to Step 6.
 - If vehicle display continues to indicate a flashing “CC” and/or “F” in gear display or service transmission message, go to Step 5.
6. Key off and wait 1 minute.
7. Key on with engine off.
8. Connect ServiceRanger.



9. Go to “Fault Codes”.
 - If an Active transmission fault code is set, go to Endurant HD Troubleshooting Guide TRTS0950 **Diagnostic Procedure**.
 - If no Active transmission fault codes are set, select “Clear Eaton Faults” and follow on-screen prompts. Go to Step 9.
10. Disconnect ServiceRanger.
11. Key off.
12. Inspect transmission for a PTO.
 - If not PTO-equipped, process complete.
 - If PTO-equipped, start the engine and run for 1 to 2 minutes to fill the PTO with oil, key off and repeat the Fill Oil Procedure.

CAUTION: Failure to repeat the Fill Oil service procedure to verify proper transmission oil level when equipped with a PTO may result in low transmission oil and component damage.

Main Housing

Special Instructions

Main Shaft End-Play must be measured and adjusted after Clutch Housing, Main Housing, Input Shaft, Input Shaft Bearing or Main Shaft Bearing replacement. Perform Main Shaft End-Play Service Procedure on page 480 to measure and adjust Main Shaft End-Play if any of the components mentioned above have been replaced.

CAUTION: Failure to measure and adjust Main Shaft End-Play could result in transmission component damage.

CAUTION: Always start Main Shaft End-Play procedure with the 6.525 mm Main Shaft Selective Washer installed. Failure to do so could result in internal component damage.

Special Tools

- Rear Housing Alignment Pins (RR1090TR)
- Upper Countershaft Pilot Tool (RR1071TR)
- Lower Countershaft Pilot Tool (RR1072TR)
- Gasket Sealant (Loctite 5188)
- Plastic Scraper
- Non-Chlorinated Brake Cleaner (Gasket Remover)

DANGER: Do not handle gasket remover until all manufacturer precautions have been read and understood. Failure to follow precautions will result in serious personal injury or death.

CAUTION: Avoid contact between gasket remover and the transmission plastic components, electrical wiring and connectors. Failure to avoid contact will result in transmission component damage.

Component Identification

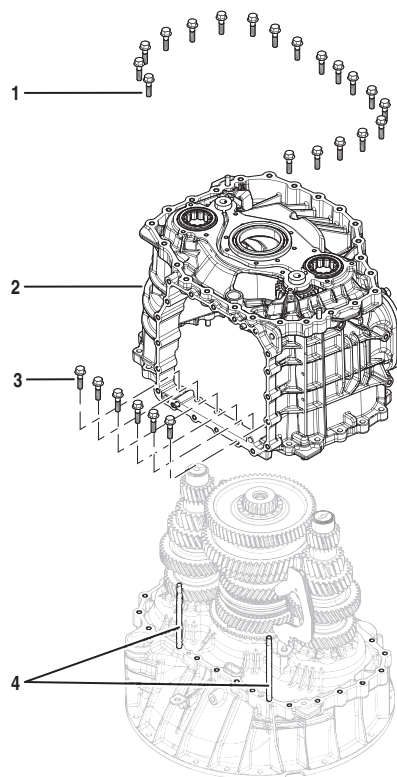

1. Main Housing External Cap Screws (x19) - 16 mm

2. Main Housing

3. Main Housing Internal Cap Screws (x6) - 16 mm

4. Rear Housing Alignment Pins (RR1090TR)

Create a Service Activity Report

Note: If not already created and sent.

1. Key on with engine off.
2. Connect ServiceRanger and create a Service Activity Report.
3. Select "Send to Eaton" (internet connection required)
4. Disconnect ServiceRanger.
5. Key off.

Drain Oil

1. Locate the Oil Drain Plug on the back of the rear housing.
2. Place a suitable container under the Oil Drain Plug.
Note: If reusing oil, use a clean container free of contamination and debris.
3. Remove the Oil Drain Plug with a 6 mm hex key and drain the oil.



4. If PTO-equipped, remove PTO and drain the oil.
5. Inspect Oil Drain Plug and O-ring for damage. If damaged, replace the Oil Drain Plug; O-ring is serviced with plug.
6. Install the Oil Drain Plug (6 mm) and torque to 24.5-29.5 Nm (18-22 lb-ft).

NOTICE: Do not over-torque drain plug or transmission damage may occur.



Manually Vent Linear Clutch Actuator (LCA)

1. Key off.
2. Set vehicle parking brake and chock wheels.

! **WARNING:** Apply vehicle parking brake and follow vehicle manufacture parking instructions. Failure to follow these instructions could cause unintended vehicle movement and may result in major vehicle component damage, severe injury or death.

3. Loosen the 4 Linear Clutch Actuator (LCA) cap screws 1-2 turns each with a T45 Torx.

Note: Residual air pressure in the LCA cylinder exhausts between the LCA and Mechatronic Transmission Module (MTM) housing when the cap screws are loosened.

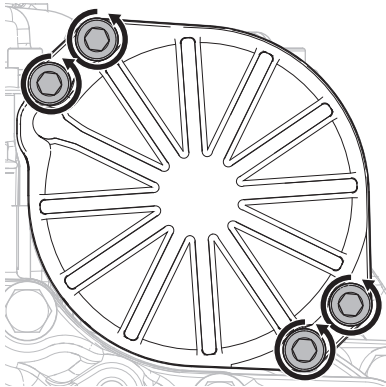

4. Tighten the 4 LCA to MTM T45 cap screws and torque to 23-27 Nm (17-21 lb-ft).

Remove the Transmission

1. Disconnect negative battery cable.
2. Refer to OEM guidelines for transmission removal.

Remove the Release Bearing and Clutch Release Yoke

1. Remove the Release Bearing by sliding the bearing off the input shaft.



2. Pull to free the lower Clutch Release Yoke socket from the lower pivot on the clutch housing.

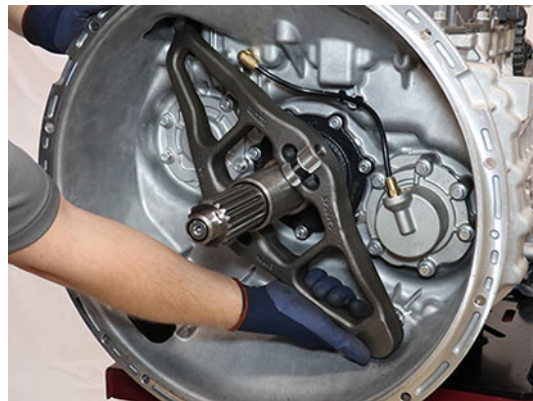

3. Pull to free the upper Clutch Release Yoke socket from the Linear Clutch Actuator (LCA) rod end.



4. Inspect the plastic socket inserts in the Clutch Release Yoke to verify none of the fingers are missing or damaged.

Note: If the plastic insert is damaged, replace the Clutch Release Yoke assembly.



Remove the Transmission Control Module (TCM)

1. Unscrew the 4 TCM Cover nuts and remove TCM Cover.

Note: TCM Cover nuts are 10 or 13 mm.



2. Unscrew the TCM 7 mm Jackscrew. Lift and remove the TCM from the MTM.

NOTICE: Do not allow contamination into the connectors on the TCM or MTM.



3. Inspect the TCM Seal for damage.

NOTICE: Replace the TCM Seal if damaged.

Note: If replacing the TCM, the REMAN TCM includes a new seal.



Remove the Mechatronic Transmission Module (MTM)

1. Lift the latch on the Output Speed Sensor Harness at the Connector on the Mechatronic Transmission Module (MTM).



2. Remove the Output Speed Sensor Harness from the Connector on the MTM.



3. Remove the 20 MTM cap screws.

Note: 13 mm (x18), 15 mm (x2).



4. Separate the MTM from the Main Housing at the 2 pry points.

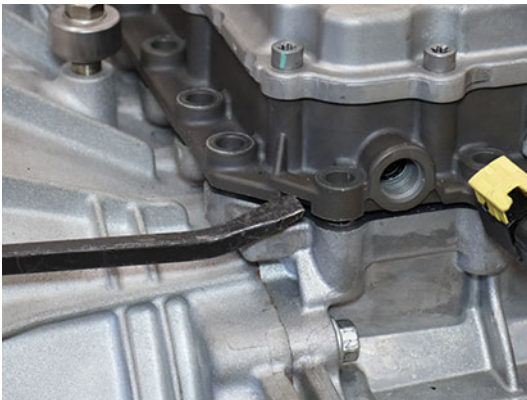
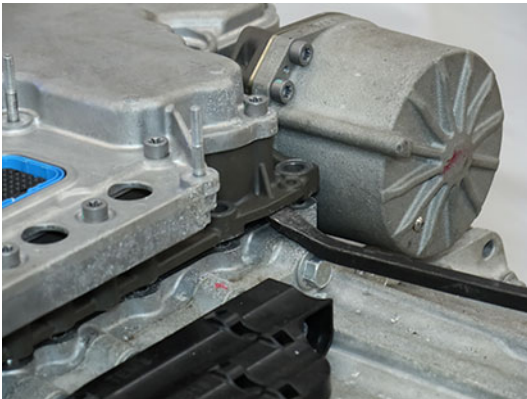

5. Remove the MTM from the transmission housing.

⚠ CAUTION: MTM weighs approximately 40 lbs. Keep fingers clear of pinch point between MTM and other surfaces. Dropping MTM could result in component damage and/or personal injury.



Remove the Output Speed Sensor

1. Remove the Output Speed Sensor Harness tie strap at the Harness Bracket.



2. Remove the 2 harness press-in retainers from the Main Housing and bracket on Rear Housing.



3. Remove the Output Speed Sensor 10 mm cap screw.



4. Remove the Output Speed Sensor from the Rear Housing.

Note: The sensor may need to be twisted and pulled from the bore.



Remove the Harness Bracket

Note: This procedure contains removing the Harness Bracket without the Mechatronic Transmission Module (MTM).

1. Remove 3 Harness Bracket 10 mm cap screws.



2. Remove Harness Bracket.



Secure Transmission (Vertical)

1. Place transmission in the vertical position with the front side down.



WARNING: Transmission weighs approximately 550 lbs. Keep fingers clear of pinch point between transmission and other surfaces. Dropping transmission may result in major vehicle component damage, severe injury or death.

NOTICE: Use an appropriate lifting device to safely lift component.

Note: Use a surface with an opening that allows the input shaft to pass through and the clutch housing to sit flat and secure.

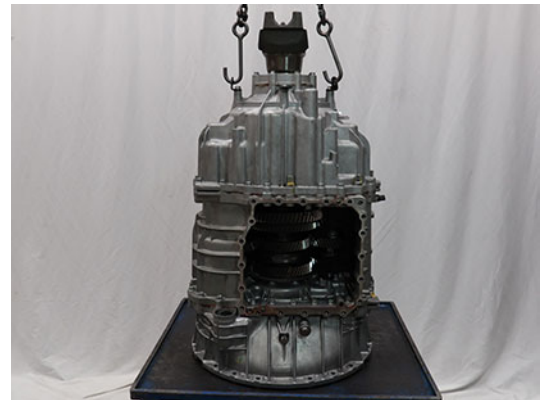

Remove the Rear Housing

1. At the 3 Rear Housing Threaded cap screws, apply paint marks on the Rear Housing to identify location.



2. Remove 21 Rear Housing and 3 threaded 16 mm cap screws.



3. Install and hand tighten 2 Rear Housing Alignment Pins (RR1090TR) 180-degrees apart.

NOTICE: Failure to install alignment pins results in transmission component damage.



4. Separate the Rear Housing from the Main Housing at the 2 pry points.



- Lift and remove Rear Housing Assembly from Main Housing.



WARNING: Rear Housing Assembly weighs approximately 170 lbs. Failure to properly secure and lift the Rear Housing Assembly may result in major vehicle component damage, severe injury or death.

NOTICE: Use an appropriate lifting device to safely lift component.

Note: Dual PTO Transmissions are equipped with a rear PTO lube tube port on the pump and rear PTO drive splines on the Upper Countershaft.

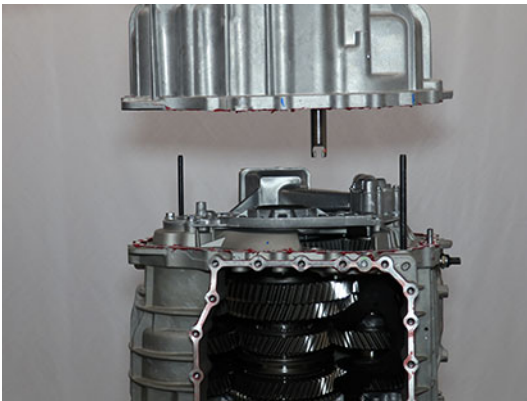

- Place Rear Housing Assembly on bench.



WARNING: Rear Housing Assembly weighs approximately 170 lbs. Keep fingers clear of pinch point between Rear Housing Assembly and other surfaces. Dropping Rear Housing may result in major vehicle component damage, severe injury or death.

NOTICE: Support the Rear Housing Assembly to prevent damage to Shift Rail E.



- Remove the 2 Rear Housing Alignment Pins (RR1090TR) from the Main Housing.

Remove the Oil Pump Assembly

1. Remove 18 Oil Pump Assembly 13 mm cap screws.



2. Remove Oil Pump Assembly.



3. Remove Oil Pump/Range Spacer with O-ring.



Remove Main Housing

1. Remove the 19 external and 6 internal Main Housing 16 mm cap screws.

NOTICE: To avoid internal transmission contamination, keep internal and external Main Housing cap screws separated.



2. Install and hand tighten 2 Rear Housing Alignment Pins (RR1090TR) in the internal Main Housing cap screw outer threaded holes.

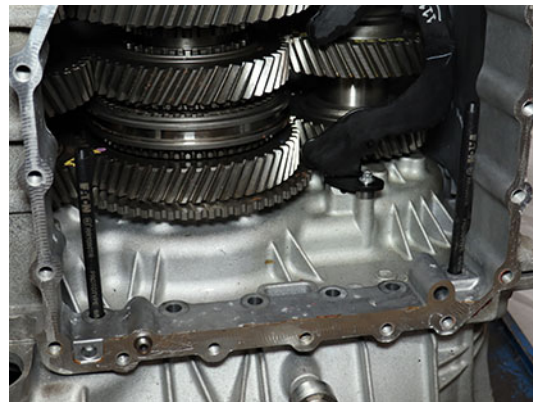

3. Remove 2 Rear Housing 90-degree Lifting Eye 15 mm cap screws from Rear Housing.



4. Install and hand tighten 2 Rear Housing 90-degree Lifting Eyes and 15 mm cap screws to Main Housing.

NOTICE: Do not over tighten cap screws.

Note: Install 90-degree Lifting Eyes 180-degrees apart to ensure even lifting.

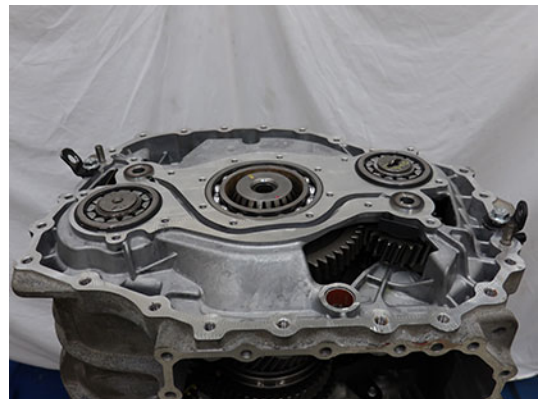

5. Separate Main Housing from Clutch Housing at the 2 pry points.



6. Lift and remove Main Housing from Clutch Housing.



CAUTION: Main Housing weighs approximately 50 lbs. Keep fingers clear of pinch point between Main Housing and other surfaces. Dropping Main Housing could result in component damage and/or personal injury.

NOTICE: Use an appropriate lifting device to safely lift component.



7. Remove 2 Rear Housing Alignment Pins (RR1090TR).



8. If Clutch Housing, Main Housing, Input Shaft, Input Shaft Bearing, or Main Shaft Bearing has been replaced, perform steps to **Install the Main Housing without Gasket Sealant** and measure Main Shaft End-Play. If these parts have NOT been replaced, perform steps to **Install Main Housing**.

Install the Main Housing without Gasket Sealant

1. Clean the sealing surfaces on the Clutch Housing and Main Housing with gasket remover and a plastic scraper. Let air dry then wipe with a clean dry cloth.

NOTICE: Do not use abrasive scrapers or powered tools to clean sealing surfaces or sealing surfaces may be damaged and leak.

2. Inspect threaded bolt holes for debris and clean if necessary.

NOTICE: Ensure there is nothing in the threaded bolt holes or the transmission may be damaged when cap screws are tightened.

3. Slide O-ring over the Clutch Housing Inertia Brake air passage alignment pin until fully seated in groove.

NOTICE: Failure to install a new O-ring could result in degraded transmission performance.

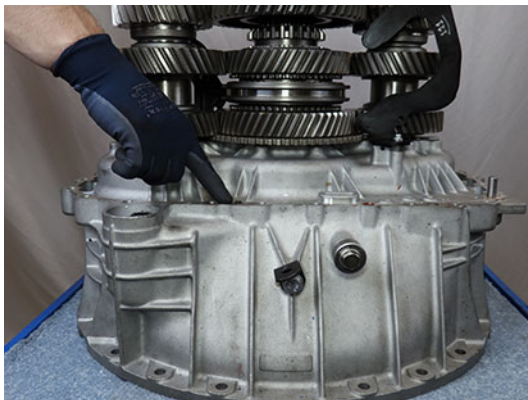

4. Install Lower Countershaft Pilot Tool (RR1071TR) onto Lower Countershaft above rear bearing race.



5. Install Upper Countershaft Pilot Tool (RR1072TR) onto the Upper Countershaft above rear bearing race.



6. Install and hand tighten 2 Rear Housing 90-degree Lifting Eyes and 15 mm cap screws to Main Housing.

NOTICE: Do not over tighten Lifting Eye cap screws.

Note: Install 90-degree Lifting Eyes 180-degrees apart to ensure even lifting.



7. Install and hand tighten 2 Rear Housing Alignment Pins (RR1090TR) into the Clutch Housing as shown below.



8. Lift, align and install Main Housing to Clutch Housing.



CAUTION: Main Housing weighs approximately 50 lbs. Keep fingers clear of pinch point between Main Housing and other surfaces. Dropping Main Housing could result in component damage and/or serious injury.

NOTICE: Use an appropriate lifting device to safely lift component.

Note: Using a flat tipped screwdriver, rotate the Reverse Idler Gears to align the gearing and allow Main Housing to fully seat onto the Clutch Housing.



9. Remove 2 Rear Housing Alignment Pins (RR1090TR).



10. Install 19 external and 6 internal Main Housing 16 mm cap screws and torque to 44–51 Nm (33–38 lb–ft) in a criss-cross pattern.

NOTICE: To avoid internal transmission contamination, keep internal and external Main Housing cap screws separated.

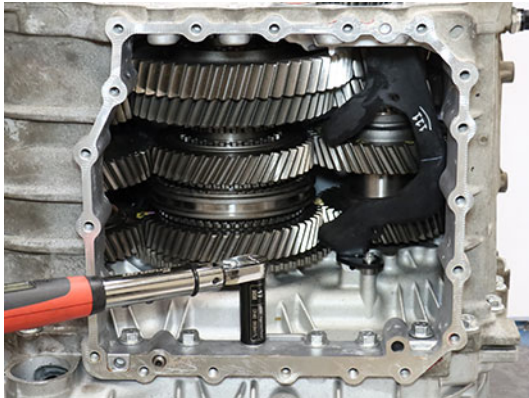

Measure and Adjust the Main Shaft End-Play

Note: The Main Shaft Selective Washer is available in 3 thicknesses: 6.525 mm (0.257 in), 6.712 mm (0.264 in) or 6.900 mm (0.272 in).

CAUTION: Ensure the Input Shaft Bearing and Main Shaft Bearing are seated in the Clutch Housing and Main Housing. Failure to fully seat bearings in housings will give an incorrect Main Shaft End-Play reading and may cause transmission component damage.

CAUTION: Ensure the 6.525 mm Main Shaft Selective Washer was installed. Only install a thicker selective washer after end-play has been measured and a thicker selective washer is required to achieve proper end-play or transmission damage may occur.

1. Install 4 Oil Pump 13 mm cap screws with flat washers (22.3 mm (0.9 in) minimum OD). Torque cap screws to 21-23 Nm (16-18 lb-ft).

Note: Flat washers are required to ensure the Main Shaft Bearing remains seated in the Main Housing during End-Play measurement.

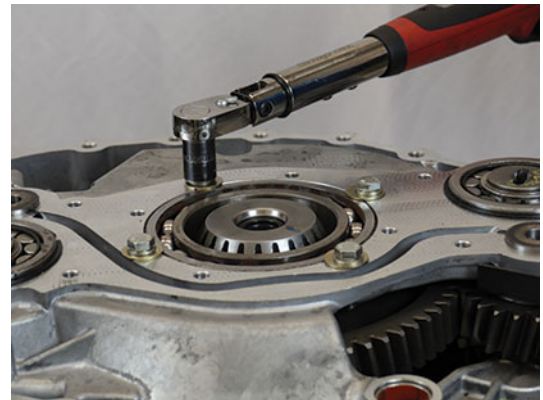

2. Thread a Dial Indicator mounting shaft into one of the inner Oil Pump mounting holes around the Main Shaft Bearing.

Note: The Oil Pump cap screw mounting holes thread pattern: M8 x 1.25 x 30 mm.



3. Mount the Dial Indicator to the shaft, set the plunger on the Main Shaft, and zero the Dial Indicator.

Note: Ensure that the Dial Indicator is vertical and zeroed for proper Main Shaft End-Play measurement.



4. Use two pry bars and slide them between the Reverse Gear and Main Housing at the locations shown below.



- Apply even downward pressure on Reverse Gear with both pry bars and monitor the Dial Indicator between the at-rest position of the Main Shaft and the point where no more downward movement is achieved. Record reading in table.

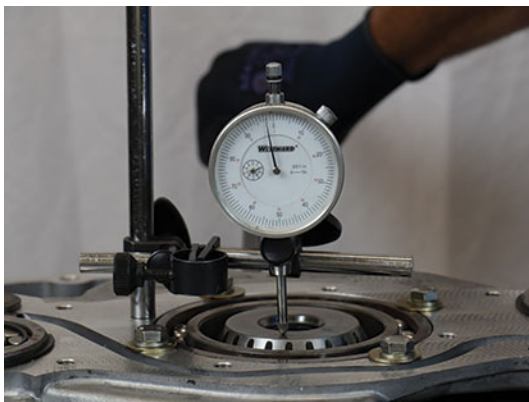
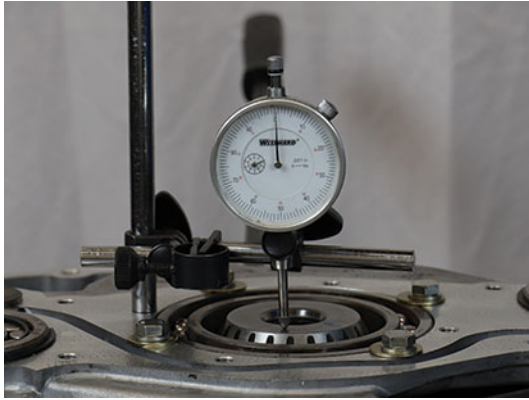

| Recorded End-Play |
|----------------------|
| |

- Reference the Selective Main Shaft Washer Reference Chart and compare Recorded End-Play to reading in table.

Note: Main Shaft End-Play specification is 0.000-0.100 mm (0.000-0.004 in). The Selective Washer Chart is only valid for end-play measured with the 6.525 mm (0.257 in) selective washer installed.

- If end-play is in range, the installed Main Shaft Selective Washer, 6.525 mm (0.257 in), is correct.
- If end-play is out of range, determine the thicker ideal Main Shaft Selective Washer and record in table. Remove Main Shaft and install the Ideal Main Shaft Selective Washer.

Main Shaft Selective Washer Reference Chart

| Recorded End-Play | Ideal Main Shaft Selective Washer Thickness and Part Number |
|------------------------------------|---|
| 0.000-0.100 mm (0.000-0.004 in) | 6.525 mm (0.257 in) P/N 10000555 |
| 0.101-0.300 mm (0.005-0.011 in) | 6.712 mm (0.264 in) P/N 10001759 |
| 0.301-0.550 mm (0.012-0.021 in) | 6.900 mm (0.272 in) P/N 10001760 |

| Ideal Main Shaft Selective Washer |
|--------------------------------------|
| |

CAUTION: Main Shaft End-Play must be remeasured after replacing Main Shaft Selective Washer or transmission component damage may occur.

Remove Main Housing

1. Remove the 19 external and 6 internal Main Housing 16 mm cap screws.

NOTICE: To avoid internal transmission contamination, keep internal and external Main Housing cap screws separated.



2. Install and hand tighten 2 Rear Housing Alignment Pins (RR1090TR) in the internal Main Housing cap screw outer threaded holes.

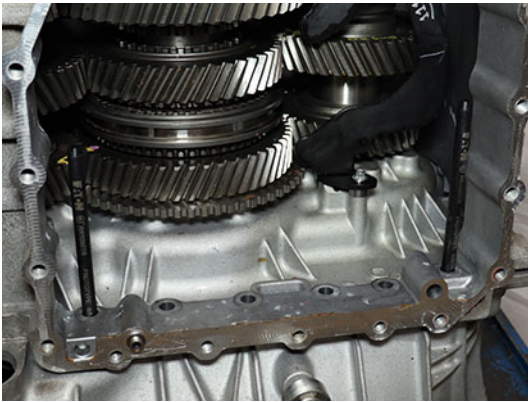

3. Separate Main Housing from Clutch Housing at the 2 pry points.



- Lift and remove Main Housing from Clutch Housing.



CAUTION: Main Housing weighs approximately 50 lbs. Keep fingers clear of pinch point between Main Housing and other surfaces. Dropping Main Housing could result in component damage and/or personal injury.

NOTICE: Use an appropriate lifting device to safely lift component.

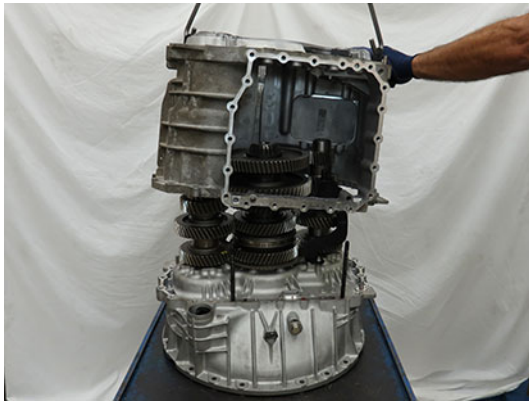

- Remove 2 Rear Housing Alignment Pins (RR1090TR).

Note: Applying sealer when installing Main Housing to Clutch Housing should only be done after proper Main Shaft End-Play has been verified.



- Reference the Selective Main Shaft Washer Reference Chart and compare Recorded End-Play to reading in table.

Note: Main Shaft End-Play specification is 0.000-0.100 mm (0.000-0.004 in). The Selective Washer Chart is only valid for end-play measured with the 6.525 mm (0.257 in) selective washer installed.

- If end-play is in range, the installed Main Shaft Selective Washer, 6.525 mm (0.257 in), is correct.
- If end-play is out of range, determine the thicker Ideal Main Shaft Selective Washer and record in table. Remove Main Shaft and install the Ideal Main Shaft Selective Washer.

Main Shaft Selective Washer Reference Chart

| Recorded End-Play | Ideal Main Shaft Selective Washer Thickness and Part Number |
|------------------------------------|---|
| 0.000-0.100 mm (0.000-0.004 in) | 6.525 mm (0.257 in) P/N 10000555 |
| 0.101-0.300 mm (0.005-0.011 in) | 6.712 mm (0.264 in) P/N 10001759 |
| 0.301-0.550 mm (0.012-0.021 in) | 6.900 mm (0.272 in) P/N 10001760 |

| Ideal Main Shaft Selective Washer |
|-----------------------------------|
| |



CAUTION: Main Shaft End-Play must be remeasured after replacing Main Shaft Selective Washer or transmission component damage may occur.

Disassemble the Main Shaft and Replace Main Shaft Selective Washer

Note: This procedure is only required if Main Shaft End-Play is out of range and a thicker Selective Washer is required.

1. Place Main Shaft Assembly horizontally on a clean flat surface.

CAUTION: Secure Main Shaft Assembly while on flat surface to avoid unexpected movement. Failure to properly secure Main Shaft Assembly could result in component damage and/or personal injury.

2. Remove Rail C Sliding Clutch.

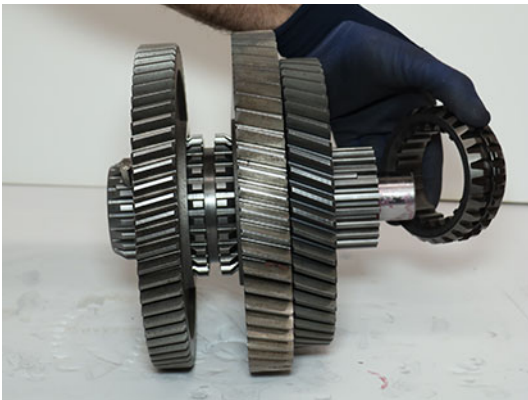

3. Place Main Shaft assembly vertically on a clean flat surface.

CAUTION: Secure Main Shaft Assembly while on flat surface to avoid unexpected movement. Failure to properly secure Main Shaft Assembly could result in component damage and/or personal injury.



4. Remove Main Shaft Key while inserting 5/32 OD air line.



5. Rotate and remove the Main Shaft Selective Washer above Reverse Gear.

Note: The Main Shaft Selective Washer above Reverse Gear is available in 3 thicknesses; 6.525, 6.712 or 6.900 mm to control Main Shaft End-Play.



Assemble and Install the Main Shaft with Replaced Main Shaft Selective Washer

1. Install and rotate the Ideal Main Shaft Selective Washer above Reverse Gear recorded in Step 6 of the Main Shaft End-Play Service Procedure.

Note: The Main Shaft Selective Washer is available in 3 thicknesses: 6.525, 6.712 or 6.900 mm.



2. Slide the 5/32 OD air line up to align and hold washer in place.



3. Install Main Shaft Key at the same spline as the 5/32 OD air line.

Note: Insert Main Shaft Key while removing air line.



4. Install a magnet on Main Shaft Key to hold the key in place during final Main Shaft Assembly and installation into transmission.

Note: Remove magnet from Main Shaft Key after installation of Main Shaft Assembly onto transmission.



5. Place Main Shaft Assembly horizontally on a clean flat surface.



CAUTION: Secure Main Shaft Assembly while on flat surface to avoid unexpected movement. Failure to properly secure Main Shaft Assembly could result in component damage and/or personal injury.

6. Install Rail C Sliding Clutch and align the double slot with Main Shaft Key.

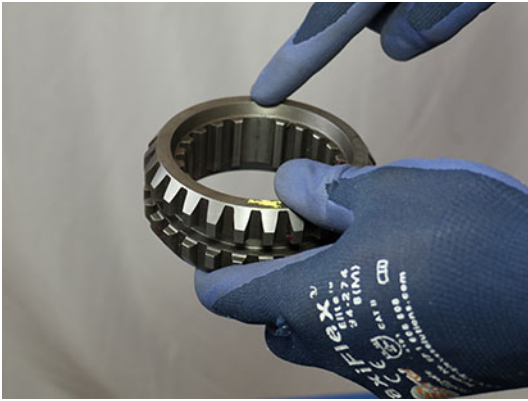

7. Apply transmission assembly lube to Wave Spring - Rear and install to Main Shaft.

NOTICE: Wave Spring - Rear is shorter than the Wave Spring - Front.

Note: Transmission assembly lube holds Wave Spring - Rear in place during Main Shaft Assembly installation.

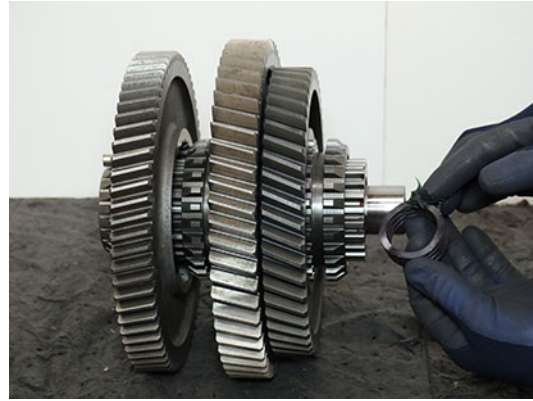

8. Apply transmission assembly lube to Thrust Washer - Rear and install to Main Shaft.

Note: Transmission assembly lube holds Thrust Washer - Rear in place during Main Shaft Assembly installation.



9. Install a magnet onto the Main Shaft Key.

Note: The magnet holds the key in position during Main Shaft Assembly installation.



10. Slide and hold Rail C Sliding Clutch into Secondary Driven Gear.



11. Install Main Shaft Assembly onto Primary Drive Gear and align gearing.



CAUTION: Main Shaft weighs approximately 35 lbs. Keep fingers clear of pinch point between Main Shaft and other surfaces. Dropping Main Shaft could result in component damage and/or personal injury.



12. Remove magnet from Main Shaft Key.

NOTICE: Ensure to remove magnet or component damage may occur during assembly.



13. If removed, install Upper Lube Tube into Clutch Housing and install 8 mm cap screw and torque to 8–10 Nm (6–13 lb-ft).



14. If removed, install Lower Lube Tube into Clutch Housing and 8 mm cap screw, torque to 8–10 Nm (6–13 lb–ft).

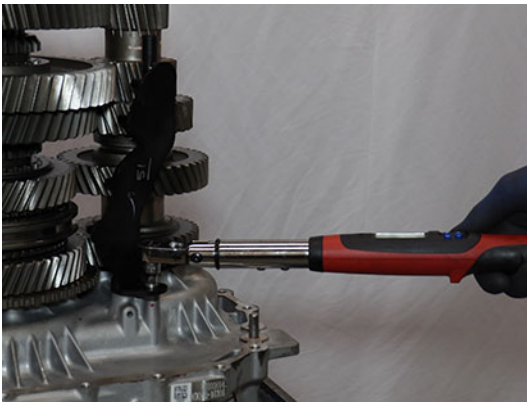

15. Perform steps to **Install the Main Housing without Gasket Sealant** and remeasure Main Shaft End-Play.



CAUTION: Main Shaft End-Play must be remeasured after replacing Main Shaft Selective Washer or transmission component damage may occur.

Install Main Housing

1. Clean the sealing surfaces on the transmission Main Housing and Rear Housing with gasket remover and a plastic scraper. Let air dry then wipe with a clean dry cloth.

NOTICE: Do not use abrasive scrapers or powered tools to clean sealing surfaces or sealing surfaces may be damaged and leak.

2. Inspect threaded bolt holes for debris and clean if necessary.

NOTICE: Ensure there is nothing in the threaded bolt holes or the transmission may be damaged when cap screws are tightened.

3. Slide O-ring over the Clutch Housing Inertia Brake air passage alignment pin until fully seated in groove.



4. Apply gasket sealant with a bead width of 1.4-2.4 mm (0.055-0.094 inch) to clutch housing as shown in pattern below.

NOTICE: Ensure there is nothing in the threaded bolt holes or the transmission may be damaged when cap screws are tightened.

Note: Parts must be assembled within 10 minutes of applying gasket sealant.

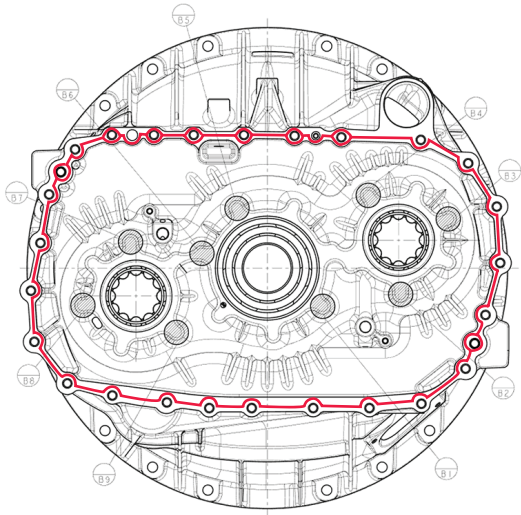

5. Install Lower Countershaft Pilot Tool (RR1071TR) onto Lower Countershaft above rear bearing race.



6. Install Upper Countershaft Pilot Tool (RR1072TR) onto the Upper Countershaft above rear bearing race.



7. Install and hand tighten 2 Rear Housing 90-degree Lifting Eyes and 15 mm cap screws to Main Housing.

NOTICE: Do not over tighten Lifting Eye cap screws.

Note: Install 90-degree Lifting Eyes 180-degrees apart to ensure even lifting.



8. Install and hand tighten 2 Rear Housing Alignment Pins (RR1090TR) into the Clutch Housing as shown below.

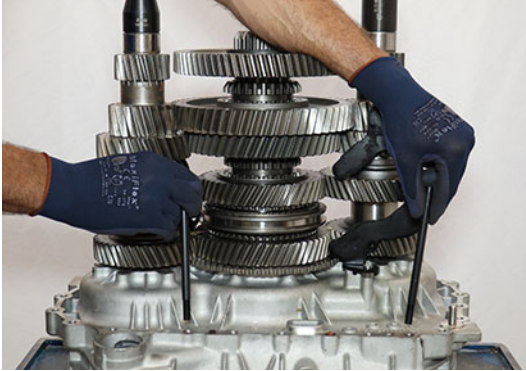

9. Lift, align and install Main Housing to Clutch Housing.



CAUTION: Main Housing weighs approximately 50 lbs. Keep fingers clear of pinch point between Main Housing and other surfaces. Dropping Main Housing could result in component damage and/or serious injury.

NOTICE: Use an appropriate lifting device to safely lift component.

Note: Using a flat tipped screwdriver, rotate the Reverse Idler Gears to align the gearing and allow Main Housing to fully seat onto the Clutch Housing.



10. Remove 2 Rear Housing Alignment Pins (RR1090TR).



11. Remove 2 Rear Housing 90-degree Lifting Eyes and 15 mm cap screws from Main Housing.



12. Re-install 2 Rear Housing 90-degree Lifting Eyes to the Rear Housing and torque to 49.6-55.5 Nm (36-40 lb-ft).



13. Install 19 external and 6 internal Main Housing 16 mm cap screws and torque to 44–51 Nm (33–38 lb-ft) in a criss-cross pattern.

NOTICE: To avoid internal transmission contamination, keep internal and external Main Housing cap screws separated.

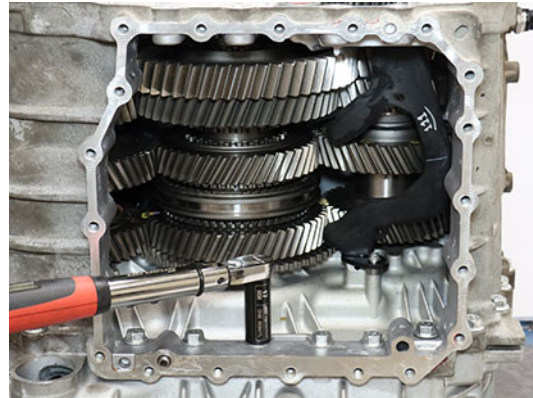

Install the Oil Pump Assembly

1. Install O-ring to the Oil Pump/Range Spacer.



2. Install Oil Pump/Range Spacer with O-ring and align tab with groove in Oil Pump Assembly.

NOTICE: Ensure the spacer tab is aligned with the groove and the spacer sits flush in the Oil Pump Assembly.



3. While holding the Oil Pump/Range Spacer in place, align oil pump drive key with slot on Lower Counter-shaft and install Oil Pump Assembly to Main Housing.



CAUTION: Failure to properly install the Oil Pump/Range Spacer and align the oil pump drive key results in transmission component damage during Oil Pump Assembly installation.

NOTICE: Ensure oil pump drive key is aligned with counter shaft drive slot during Oil Pump Assembly installation.



4. Press Oil Pump Assembly to ensure it sits flat on Main Housing sealing surface.



5. Install 18 Oil Pump Assembly 13 mm cap screws and torque to 21–23 Nm (16–18 lb–ft) in a criss-cross pattern.

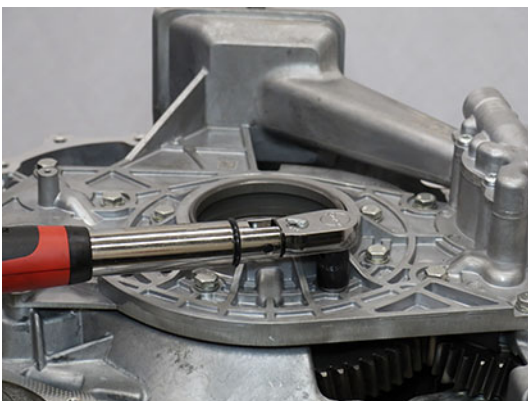
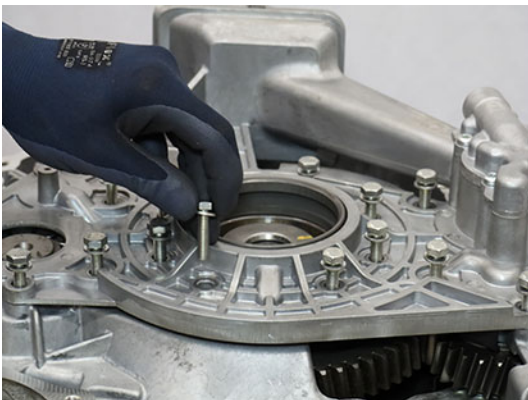

Install the Rear Housing

1. Clean the sealing surfaces on the transmission Main Housing and Rear Housing with gasket remover and a plastic scraper. Let air dry then wipe with a clean dry cloth.

NOTICE: Do not use abrasive scrapers or powered tools to clean sealing surfaces or sealing surfaces may be damaged and leak.

2. Inspect threaded bolt holes for debris and clean if necessary.

3. Apply Gasket Sealant with a bead width of 1.4-2.4 mm (0.055-0.094 inch) to the transmission Main Housing sealing surface following the pattern below.

NOTICE: Ensure there is nothing in the threaded bolt holes or the transmission housing may be damaged when cap screws are tightened.

Note: Parts must be assembled within 10 minutes of applying Gasket Sealant.

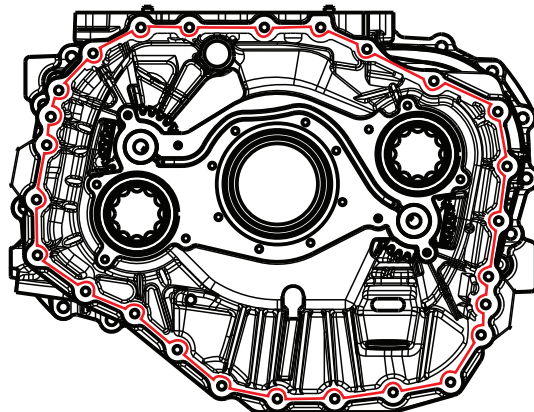

4. Install and hand tighten 2 Rear Housing Alignment Pins (RR1090TR) 180-degrees apart.



CAUTION: Failure to install alignment pins results in transmission component damage during Rear Housing Assembly installation.

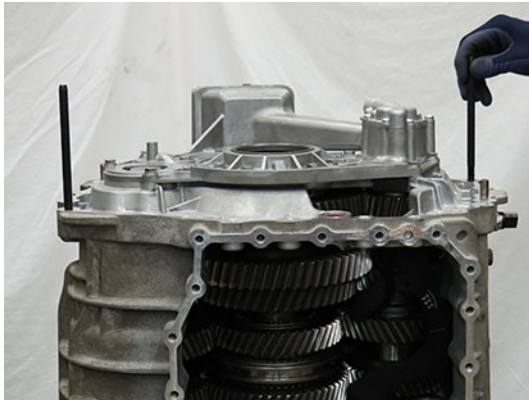

6. Install the 3 Rear Housing Threaded 16 mm cap screws at the 3 paint mark locations.

Note: Two cap screws are used to mount the harness bracket and the third is used by the OEM for additional attachment points.



5. Lift and install the Rear Housing Assembly on to the Main Housing.



WARNING: Rear Housing Assembly weighs approximately 170 lbs. Failure to properly secure and lift the Rear Housing may result in major vehicle component damage, severe injury or death.

NOTICE: Use an appropriate lifting device to safely lift component.

Note: Align the Rear Housing to the alignment pins and align Shift Rail E into the Main Housing during installation.

Note: Rotate Output Shaft to align gearing and allow Rear Housing Assembly to fully seat on Main Housing.



7. Remove the 2 Rear Housing Alignment Pins (RR1090TR).

8. Install the remaining 21 Rear Housing 16 mm cap screws and torque to 44.5 - 51.5 Nm (33-38 lb-ft) in a criss-cross pattern.

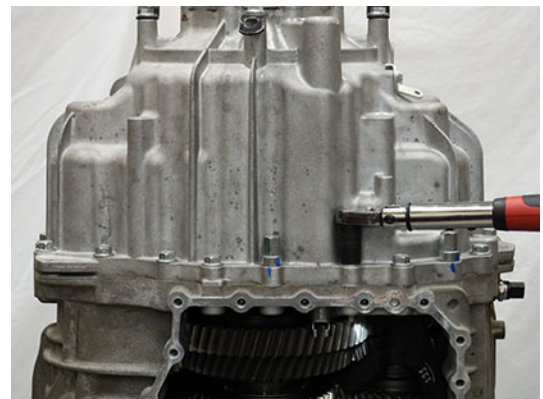

9. Lift transmission horizontally onto a bench.



WARNING: Transmission weighs approximately 550 lbs. Keep fingers clear of pinch point between transmission and other surfaces. Dropping transmission may result in major vehicle component damage, severe injury or death.

NOTICE: Use an appropriate lifting device to safely lift component.

Secure Transmission (Horizontal)

1. Securely place transmission in the horizontal position with the front side down.



WARNING: Transmission weighs approximately 550 lbs. Keep fingers clear of pinch point between transmission and other surfaces. Dropping transmission may result in major vehicle component damage, severe injury or death.

NOTICE: Use an appropriate lifting device to safely lift component.

Install the Harness Bracket

Note: This procedure contains installing the Harness Bracket without the Mechatronic Transmission Module (MTM).

1. Install Harness Bracket.



2. Install 3 Harness Bracket 10 mm cap screws and torque to 8.8 - 10.4 Nm (6-8 lb-ft).



Install the Output Speed Sensor

1. Clean the sensor bore.

NOTICE: Do not use abrasive scrapers or powered tools to clean sealing surface.

2. Apply a light coat of transmission oil to the sensor O-ring.
3. Install the Output Speed Sensor into the bore.

Note: The Sensor may need to be twisted and pushed into the bore.



4. Install the Output Speed Sensor 10 mm cap screw and torque to 8.8-10.4 Nm (6-8 lb-ft).



5. Press the 2 harness press-in retainers into the Main Housing and the bracket on the rear housing.



6. Secure the Output Speed Sensor Harness to the Harness Bracket with a tie strap.



CAUTION: Failure to tie strap the Output Speed Sensor Harness to the Harness Bracket may result in harness damage.

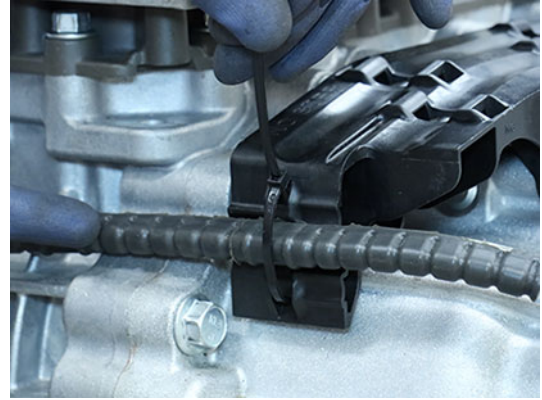

Install the Mechatronic Transmission Module (MTM)

Note: If replacing original equipment MTM with new/replacement MTM locate new/replacement MTM part information tag and record Part Number and Serial Number. Refer to Component Identification section. Part Number and Serial Number are required to properly configure TCM after MTM installation.

1. Place the transmission in a horizontal position.

NOTICE: The transmission must be in a horizontal position prior to the MTM Installation procedure. Failure to do so causes the sliding clutches to move out of neutral and not align to the shift yokes. If the shift yokes are not aligned to the sliding clutches, position sensor fault codes set Active and the transmission will not shift out of neutral.

2. Clean the sealing surfaces on the transmission and Mechatronic Transmission Module (MTM) with gasket remover and a plastic scraper. Let air dry then wipe with a clean dry cloth.

NOTICE: Do not use abrasive scrapers or powered tools to clean sealing surfaces or sealing surfaces may be damaged and leak.

3. Inspect threaded bolt holes for debris and clean if necessary.

NOTICE: Ensure there is nothing in the threaded bolt holes or the transmission may be damaged when cap screws are tightened.

4. Install the Rail B Engagement Tool (RR1088TR) to the Main Housing and hand tighten with 2 MTM cap screws.



5. Shift the Rail B Synchronizer to neutral.

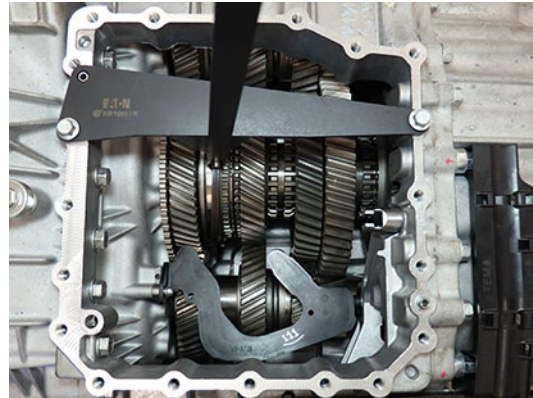

6. Remove the Rail B Engagement Tool.
7. Move Rail C and Rail D sliding clutches to neutral.

NOTICE: The transmission must be in a horizontal position prior to the MTM Installation procedure. Failure to do so causes the sliding clutches to move out of neutral and not align to the shift yokes. If the shift yokes are not aligned to the sliding clutches, position sensor fault codes set Active and the transmission will not shift out of neutral.

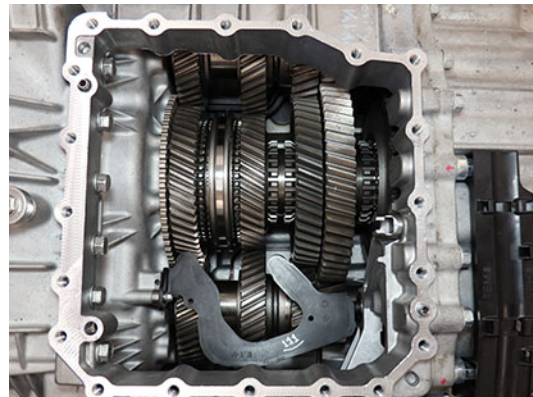

8. Install the Confirm-Neutral Gauge (RR1086TR-2) into the slots of the synchronizer and sliding clutches.



9. Install the MTM Alignment Tool (RR1086TR-1) onto the main housing.

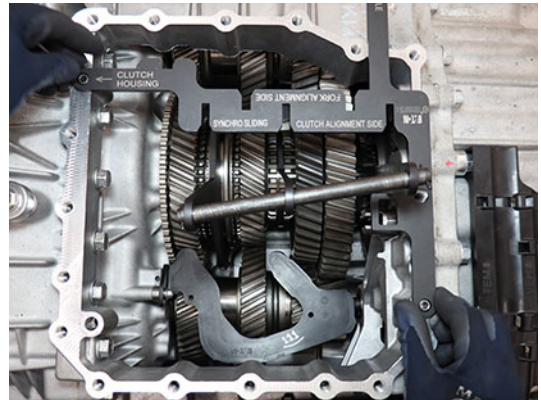
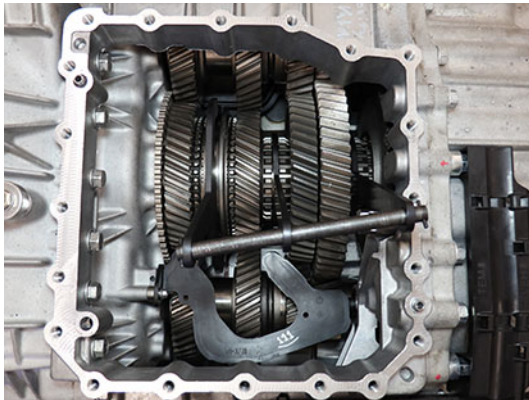
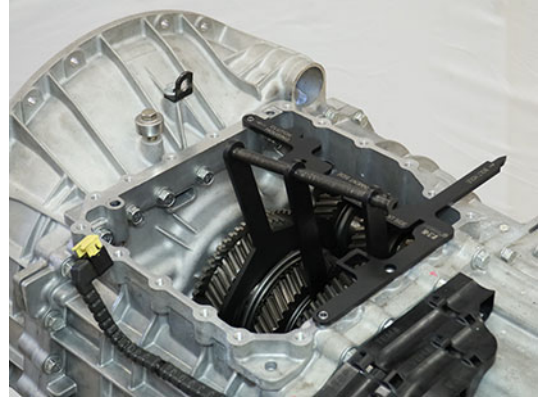

10. Verify synchronizer and sliding clutches are in neutral by sliding Confirm-Neutral Gauge into the slots of MTM Alignment Tool.

Note: If the gauge does not slide into the alignment tool slots, neutral is not achieved. Go to Step 4.

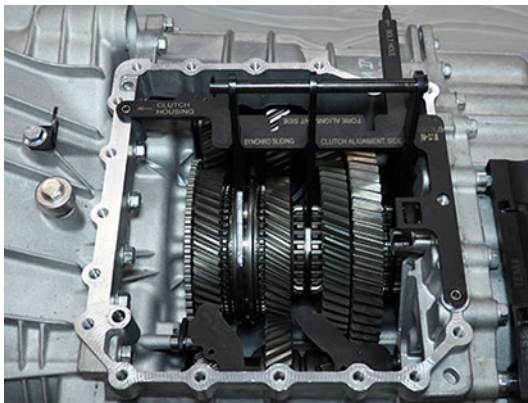

11. Using the Rail E Lever, move Rail E to neutral.

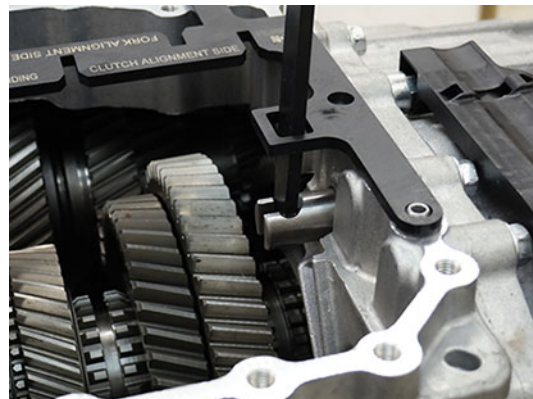
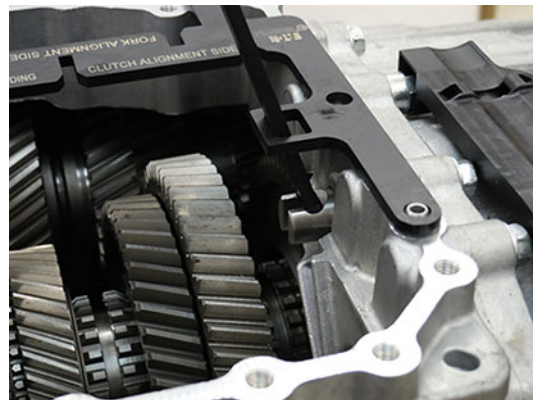
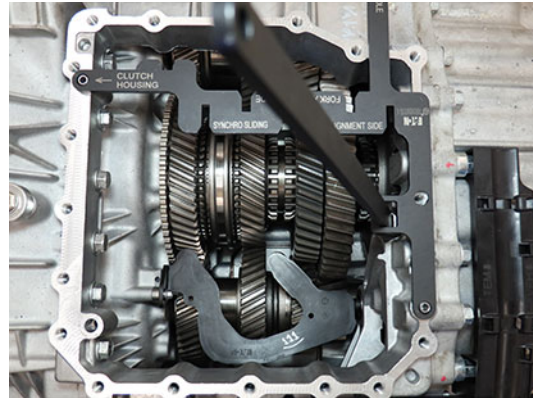

- 12.** Verify Rail E is in neutral using the Gear Side Actuator end of the Confirm-Neutral Gauge (RR1088TR-2) at Shift Rail E. Rail E is in neutral when end of gauge rests against housing with rail against notch-end of gauge.

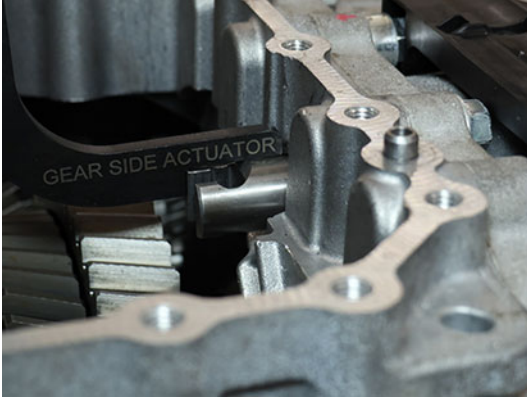

- 13.** Move Shift Rail B in the MTM to neutral. Rail B is in neutral when the ball detent is in the notch of the Rail B yoke assembly.

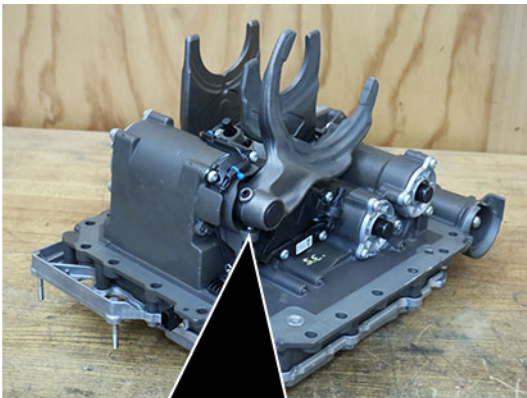

- 14.** Move Shift Rails C and D in the MTM to neutral. Rails C and D are in neutral when the shift inter-lock is aligned with the notches of the rail yoke assemblies.

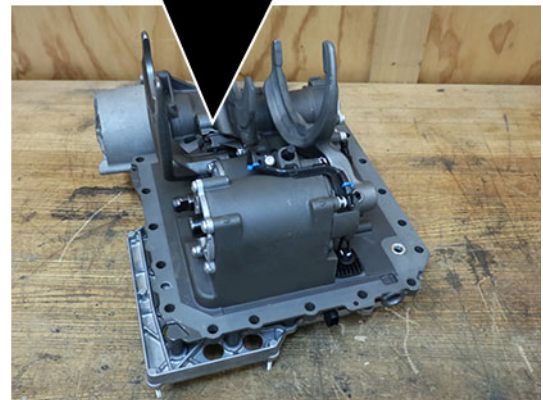

15. Verify MTM is in neutral. Install the MTM Alignment Tool (RR1086TR-1) into the bolt hole and onto Rail B, C, and D Shift Yokes.

Note: If the MTM Alignment Tool slots do not align with the 3 shift yokes, neutral has not been achieved. Go to Step 13.



16. Verify notch on Rail E is facing up.

Note: If MTM is installed on transmission with notch on Rail E facing down, Fault Code/SPN 320/5942 sets Active and transmission does not shift out of neutral.

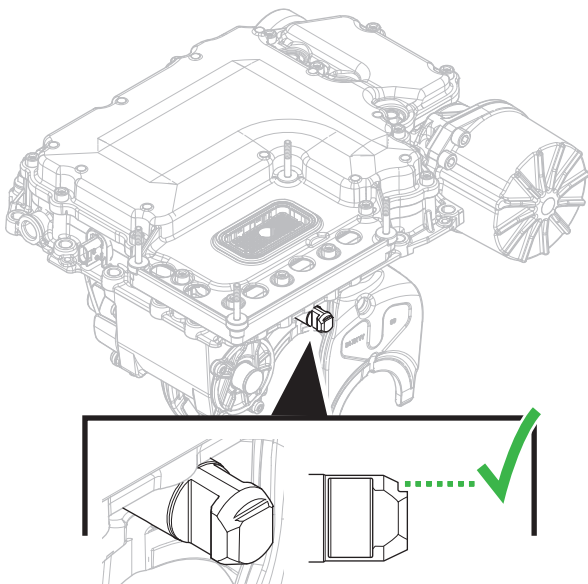

17. Verify Rail E is in neutral using the Fork Side Actuator end of the Confirm-Neutral Gauge (RR1088TR-2) at Shift Rail E. Rail E is in neutral when end of gauge rests against cover with rail against notch-end of gauge.

Note: If Rail E is not in neutral, slide rail in or out until neutral is achieved.



18. Slide O-ring over the MTM front alignment pin on the main housing until fully seated in the groove.

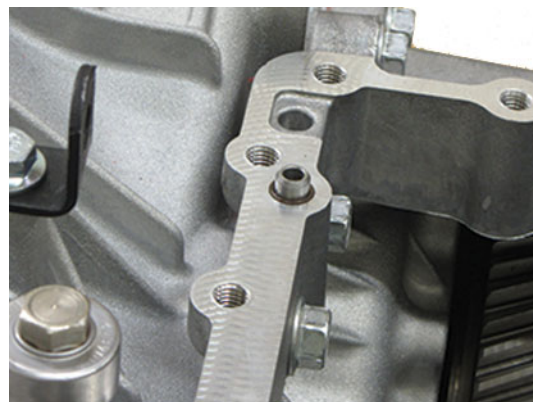

19. Clean the sealing surfaces on the transmission and Mechatronic Transmission Module (MTM) with gasket remover and a plastic scraper. Let air dry then wipe with a clean dry cloth.

NOTICE: Do not use abrasive scrapers or powered tools to clean sealing surfaces or sealing surfaces may be damaged and leak.

20. Apply gasket sealant with a bead width of 1.4-2.4mm (0.055-0.094 inch) to the transmission housing sealing surface following the pattern below.

NOTICE: Ensure there is nothing in the threaded bolt holes or the transmission may be damaged when cap screws are tightened.

Note: Parts must be assembled within 10 minutes of applying Gasket Sealant.

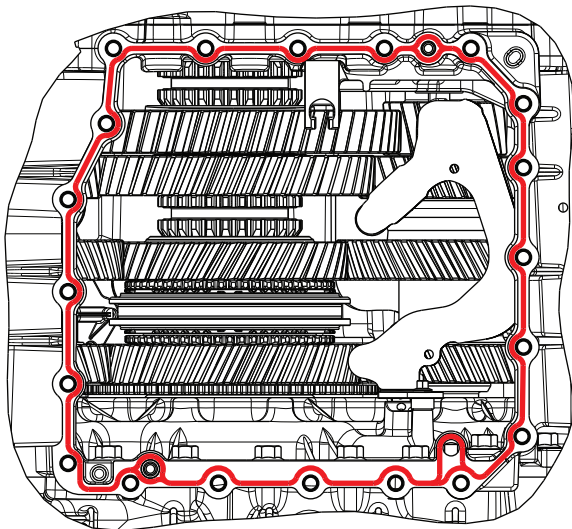

21. Install MTM onto the transmission housing. Align Rail E in the MTM with the Rail E Shift Rail in the Main Housing.

CAUTION: MTM weighs approximately 40 lbs. Keep fingers clear of pinch point between MTM and other surfaces. Dropping MTM could result in component damage and/or personal injury.

NOTICE: If the MTM is installed on the transmission and Rail E in the MTM is not aligned with Rail E in the Main Housing, Fault Code 320 (SPN 5942) sets Active and the transmission will not shift out of neutral.

22. Install 20 MTM cap screws and torque to 44.5-51.5 Nm (33-38 lb-ft) in a criss-cross pattern.

Note: 13 mm (x18), 15 mm (x2) cap screws.



Install the Transmission Control Module (TCM)

NOTICE: Do not allow contamination into the connectors on the TCM or MTM.

Note: TCM can be installed with transmission in-vehicle.

1. Install the TCM Seal on the 74-Way Harness Connector.



2. Align the TCM to the 74-Way Harness Connector and TCM studs, then install the TCM.

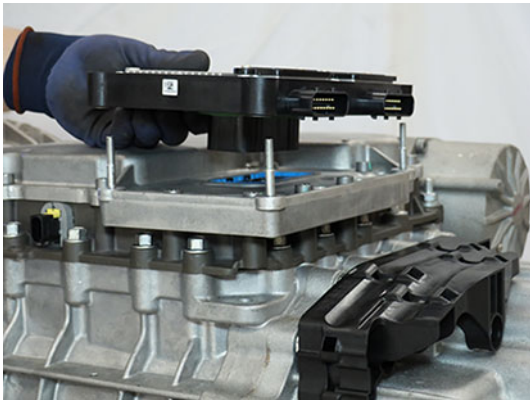

3. Torque the TCM 7 mm Jackscrew to 3.0-4.0 Nm (26.6-35.4 lb-in).

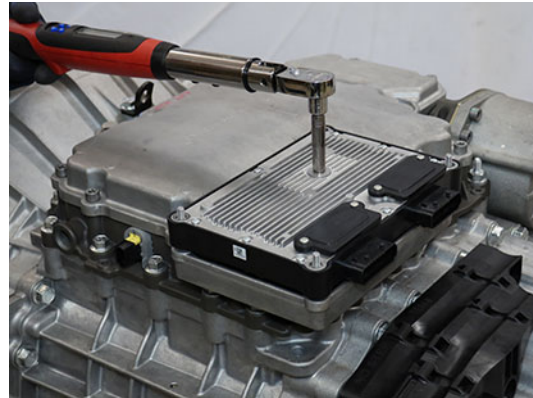

4. Install the TCM Cover over the 4 TCM studs and torque the 4 TCM Cover Nuts to 8.8-10.4 Nm (78-92 lb-in) in a criss-cross pattern.

Note: TCM Cover nuts are 10 or 13 mm.



Remove the Linear Clutch Actuator (LCA)

1. Loosen the 4 LCA cap screws 1-2 turns each with a T45 Torx.

NOTICE: Ensure key is off, 20-Way TCM Vehicle and Body Harness Connectors are disconnected, and 5 minutes has passed prior to LCA removal.

Note: Residual air pressure in the LCA cylinder exhausts between the LCA and MTM housing when the cap screws are loosened.



2. Remove the 4 LCA cap screws
3. Remove the LCA from the MTM.

Note: LCA piston rod end is seated in the release yoke socket; pull to release rod end from socket.



4. Inspect the plastic socket insert in the release yoke through the LCA opening using a flashlight to verify none of the fingers are missing or damaged.

Note: If the plastic insert is damaged, replace the release yoke assembly.

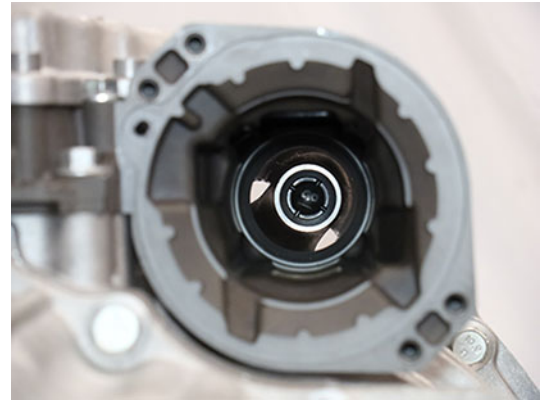

Reset and Install Linear Clutch Actuator (LCA)

1. Inspect LCA to determine next steps, reference images below:
 - If LCA is locked in the reset position, go to Install Linear Clutch Actuator (LCA).
 - If LCA is not locked in the reset position, go to Step 2.

Locked in Reset Position

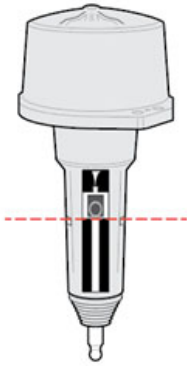

Not Locked in Reset Position

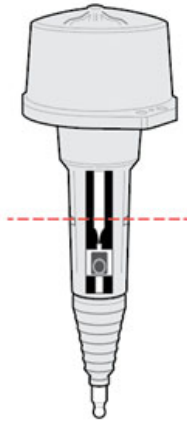

3. Inspect LCA to determine next steps, reference images below:
 - If LCA remains locked in the reset position, go to Step 4.
 - If LCA does not remain locked in the reset position, go to Step 2, repeat reset procedure.

Note: If LCA cannot be locked into the reset position, replace LCA.

CAUTION: Do not drop LCA. Dropping LCA may cause the LCA to unlock resulting in personal injury and/or component damage.

Locked in Reset Position

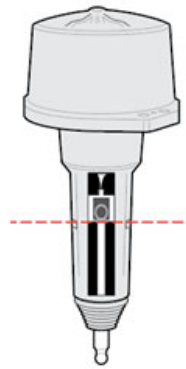

Not Locked in Reset Position

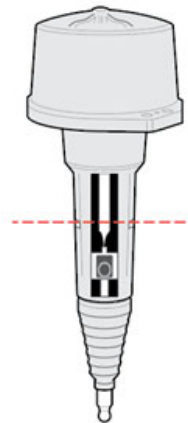

2. Place LCA push rod on a clean, flat surface. Tightly grasp LCA housing with both hands and push down on push rod to lock LCA into the reset position.



CAUTION: A large amount of force is required to lock the LCA into the reset position. Failure to tightly grasp the LCA housing with both hands while pushing down on push rod may cause unintended movement resulting in personal injury and/or component damage.



4. Clean all sealing surfaces on the MTM and LCA with a lint free cloth.

NOTICE: Do not use abrasive scrapers or powered tools to clean sealing surfaces or sealing surfaces may be damaged and leak.

5. Insert the LCA into the MTM.



6. Install 4 LCA T45 cap screws and torque to 23-28 Nm (17-21 lb-ft) in a criss-cross pattern.

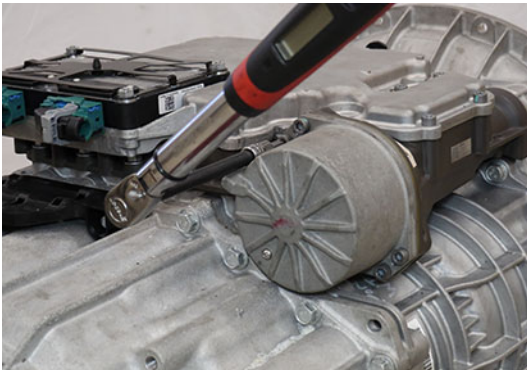

Install the Release Bearing and Clutch Release Yoke

1. Install the upper Release Yoke socket over the rod end of the Linear Clutch Actuator (LCA) and press until attached.



2. Install the lower Release Yoke socket over the lower pivot on the clutch housing and press until attached.



3. Slide the Release Bearing over the input shaft and into the Release Yoke.



Install the Transmission

1. Refer to OEM guidelines for transmission installation.
2. Connect negative battery cable.

Fill Oil

Note: Perform the transmission fill procedure with transmission installed in vehicle to ensure proper transmission angle.

1. Remove the Oil Fill Plug with a 6 mm hex key.

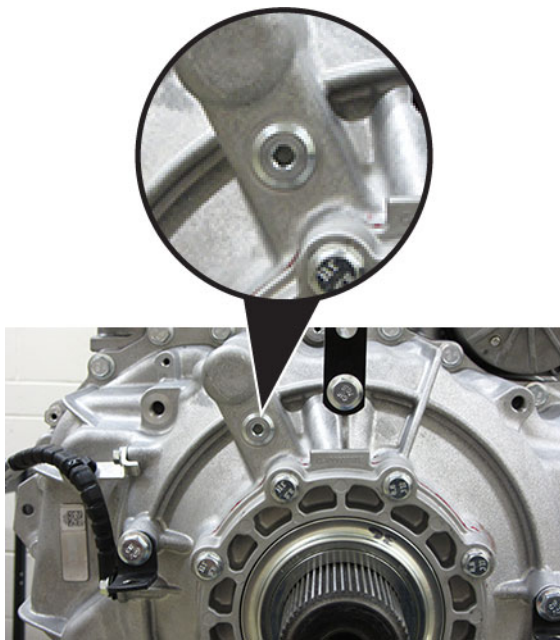

2. Place a suitable container under the Oil Check Plug and remove the Oil Check Plug with a 6 mm hex key.



3. Fill the transmission with PS-386 lube until a small amount of oil runs out of the Oil Check Plug hole.

Note: Fill capacity is approximately 7.5-8.5 liters (16-18 pints) depending on the transmission angle.

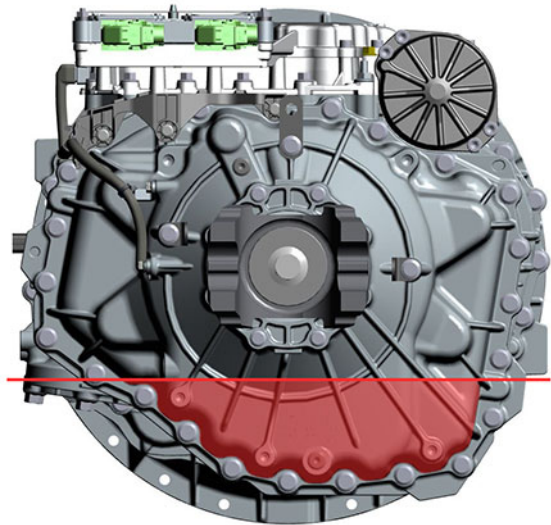
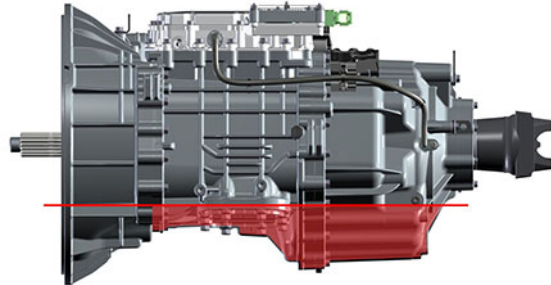

4. Inspect Oil Check Plug and O-ring for damage. If damaged, replace the Oil Check Plug; O-ring is serviced with plug.

5. Install the Oil Check Plug (6 mm) and torque to 24.5-29.5 Nm (18-22 lb-ft).

NOTICE: Do not over-torque the Oil Fill Plug or transmission damage may occur.



6. Inspect Oil Fill Plug and O-ring for damage. If damaged, replace the Oil Fill Plug; O-ring is serviced with plug.
7. Install the Oil Fill Plug (6 mm) and torque to 24.5-29.5 Nm (18-22 lb-ft).

NOTICE: Do not over-torque the Oil Fill Plug or transmission damage may occur.

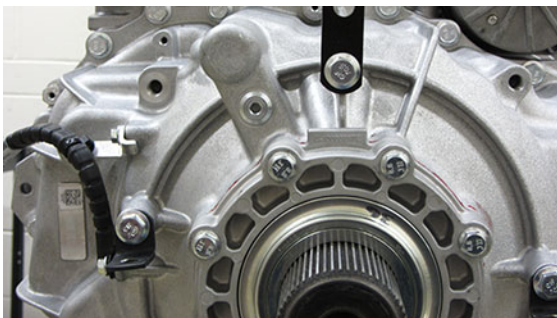

Clutch and Rail Calibration

To ensure proper operation, the TCM, clutch, MTM and transmission require a Clutch and Rail Calibration. Calibrations are automatically initiated when:

- LCA is in the reset position
- Transmission in "N" (Neutral)
- Key on engine running
- Vehicle air system pressure at operating range

NOTICE: Do not use service tool to initiate calibrations. Allow calibrations to automatically initiate.

Note: Vehicle display may indicate a flashing "CC" and "F" in gear display.

1. Set vehicle parking brake and chock wheels.
2. Ensure the driveline is connected between the transmission and axle.

Note: Clutch and Rail Calibrations cannot complete if the transmission output shaft is allowed to rotate.
3. Key on with engine running.
4. Allow vehicle air pressure to build to governor cut-off.

Note: Clutch and Rail Calibrations automatically initiate when vehicle air pressure reaches approximately 100 psi.
5. Ensure "N" (Neutral) is selected and engine is running. Wait approximately 2 minutes for calibrations to complete.

NOTICE: If process is interrupted, key off, wait 1 minute and go to Step 2.

- If vehicle display indicates a solid "N: (Neutral) in gear display, calibrations are complete. Key off, go to Step 6.
 - If vehicle display continues to indicate a flashing "CC" and/or "F" in gear display or service transmission message, go to Step 5.
6. Key off and wait 1 minute.
 7. Key on with engine off.
 8. Connect ServiceRanger.

9. Go to “Fault Codes”.
 - If an Active transmission fault code is set, go to Endurant HD Troubleshooting Guide TRTS0950 **Diagnostic Procedure**.
 - If no Active transmission fault codes are set, select “Clear Eaton Faults” and follow on-screen prompts. Go to Step 9.
10. Disconnect ServiceRanger.
11. Key off.
12. Inspect transmission for a PTO.
 - If not PTO-equipped, process complete.
 - If PTO-equipped, start the engine and run for 1 to 2 minutes to fill the PTO with oil, key off and repeat the Fill Oil Procedure.



CAUTION: Failure to repeat the Fill Oil service procedure to verify proper transmission oil level when equipped with a PTO may result in low transmission oil and component damage.

Main Shaft and Countershaft

Special Instructions

Main Shaft End-Play must be measured and adjusted after Clutch Housing, Main Housing, Input Shaft, Input Shaft Bearing or Main Shaft Bearing replacement. Perform Main Shaft End-Play Service Procedure on page 480 to measure and adjust Main Shaft End-Play if any of the components mentioned above have been replaced.

CAUTION: Failure to measure and adjust Main Shaft End-Play could result in transmission component damage.

CAUTION: Always start Main Shaft End-Play procedure with the 6.525 mm Main Shaft Selective Washer installed. Failure to do so could result in internal component damage.

Component Identification

1. Primary Drive Gear
2. Spherical Washer - Front
3. Bearing Race - Front
4. Needle Bearing - Front
5. Thrust Bearing - Front
6. Thrust Washer - Front
7. Wave Spring - Front
8. Rail B Synchronizer Ring
9. Rail B Synchronizer Sliding Sleeve
10. Rail B Synchronizer Rollers (x3)
11. Synchronizer Springs and Plungers (x3)
12. Lower Lube Tube Cap Screw - 8 mm
13. Lower Lube Tube
14. Upper Countershaft
15. Main Shaft Assembly
16. Wave Spring - Rear
17. Thrust Washer - Rear
18. Thrust Bearing - Rear
19. Needle Bearing - Rear
20. Bearing Race - Rear
21. Upper Lube Tube Cap Screw - 8 mm
22. Upper Lube Tube
23. Lower Countershaft
24. Input Shaft Assembly
25. Countershaft Flat Washers (x2)
26. Countershaft Snap Rings (x2)
27. Input Shaft Snap Ring

Special Tools

- Magnet
- Upper Countershaft Pilot Tool (RR1071TR)
- Lower Countershaft Pilot Tool (RR1072TR)
- Transmission Assembly Lube (Assemblee Goo™ - Firm Tack Green #19250 or equivalent)
- Plastic Scraper
- Non-Chlorinated Brake Cleaner (Gasket Remover)

DANGER: Do not handle non-chlorinated brake cleaner until all manufacturer precautions have been read and understood. Failure to follow precautions will result in serious personal injury or death.

CAUTION: Avoid contact between non-chlorinated brake cleaner and the transmission plastic components, electrical wiring and connectors. Failure to avoid contact will result in transmission component damage.

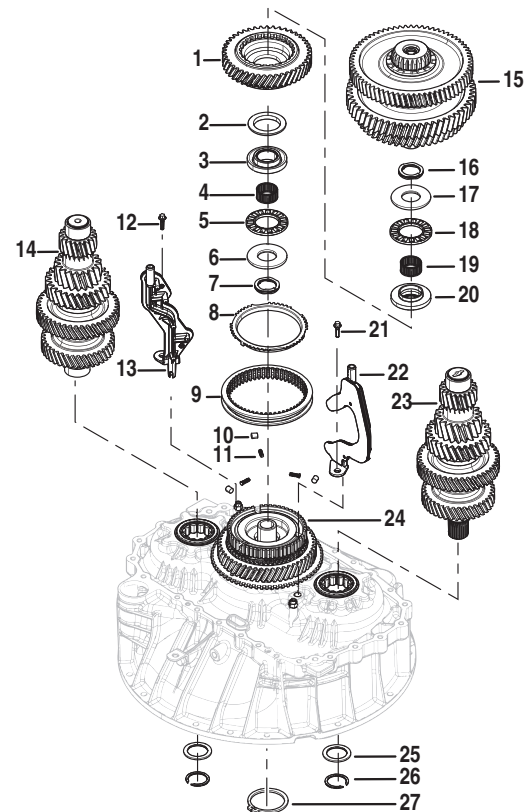

Create a Service Activity Report

Note: If not already created and sent.

1. Key on with engine off.
2. Connect ServiceRanger and create a Service Activity Report.
3. Select "Send to Eaton" (internet connection required)
4. Disconnect ServiceRanger.
5. Key off.

Drain Oil

1. Locate the Oil Drain Plug on the back of the rear housing.
2. Place a suitable container under the Oil Drain Plug.

Note: If reusing oil, use a clean container free of contamination and debris.

3. Remove the Oil Drain Plug with a 6 mm hex key and drain the oil.

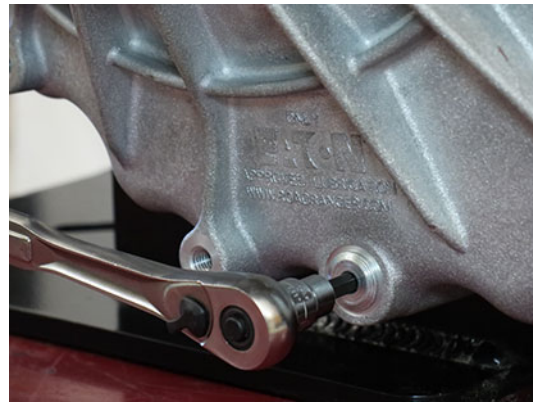

4. If PTO-equipped, remove PTO and drain the oil.
5. Inspect Oil Drain Plug and O-ring for damage. If damaged, replace the Oil Drain Plug; O-ring is serviced with plug.
6. Install the Oil Drain Plug (6 mm) and torque to 24.5-29.5 Nm (18-22 lb-ft).

NOTICE: Do not over-torque drain plug or transmission damage may occur.

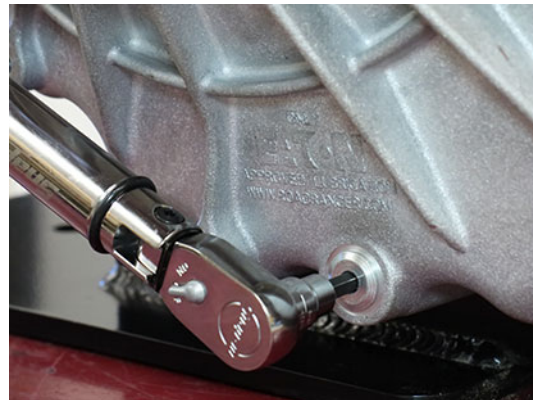

Manually Vent Linear Clutch Actuator (LCA)

1. Key off.
2. Set vehicle parking brake and chock wheels.

! **WARNING:** Apply vehicle parking brake and follow vehicle manufacture parking instructions. Failure to follow these instructions could cause unintended vehicle movement and may result in major vehicle component damage, severe injury or death.

3. Loosen the 4 Linear Clutch Actuator (LCA) cap screws 1-2 turns each with a T45 Torx.

Note: Residual air pressure in the LCA cylinder exhausts between the LCA and Mechatronic Transmission Module (MTM) housing when the cap screws are loosened.

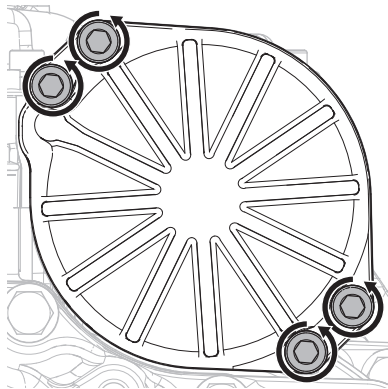

4. Tighten the 4 LCA to MTM T45 cap screws and torque to 23-27 Nm (17-21 lb-ft).

Remove the Transmission

1. Disconnect negative battery cable.
2. Refer to OEM guidelines for transmission removal.

Remove the Release Bearing and Clutch Release Yoke

1. Remove the Release Bearing by sliding the bearing off the input shaft.



2. Pull to free the lower Clutch Release Yoke socket from the lower pivot on the clutch housing.

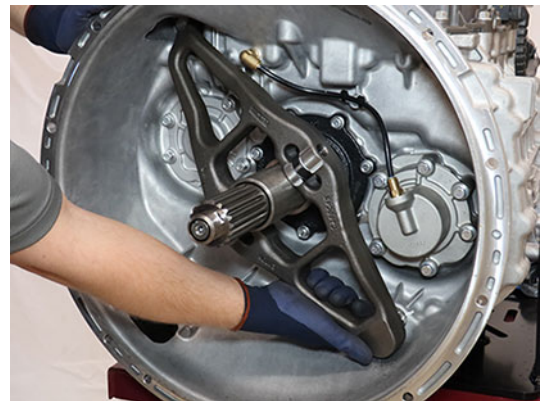

3. Pull to free the upper Clutch Release Yoke socket from the Linear Clutch Actuator (LCA) rod end.



4. Inspect the plastic socket inserts in the Clutch Release Yoke to verify none of the fingers are missing or damaged.

Note: If the plastic insert is damaged, replace the Clutch Release Yoke assembly.



Remove the Upper Countershaft Cover

1. Remove the 6 Upper Countershaft Cover 13 mm cap screws and remove cover.



2. Remove the Upper Countershaft Cover Seal.

NOTICE: A new Upper Countershaft Cover Seal is required when reinstalling or an oil leak may occur.

Note: Reference "RRMT0027 - Clutch Housing Front Cover Kit" on page 586 for new Upper Countershaft Cover part number, additional O-ring part number, and installation instructions.



Remove Upper Countershaft Snap Ring and Flat Washer

1. Remove Upper Countershaft Snap Ring and Flat Washer.

NOTICE: A new snap ring is required when reinstalling.



Remove the Lower Countershaft Cover and Inertia Brake

1. Depress and hold collar on air line fitting and disconnect the air line from the Inertia Brake Cover.



2. Remove the 6 Inertia Brake Cover 13 mm cap screws.



3. Remove the Inertia Brake Cover and Housing as an assembly.



4. Remove Piston Pin from the end of the lower countershaft.



5. Remove the Return Spring from the end of the lower countershaft using a magnet.



Remove Lower Countershaft Snap Ring and Flat Washer

1. Remove Lower Countershaft Snap Ring and Flat Washer.

NOTICE: A new snap ring is required when reinstalling.



Remove the Transmission Control Module (TCM)

1. Unscrew the 4 TCM Cover nuts and remove TCM Cover.

Note: TCM Cover nuts are 10 or 13 mm.



2. Unscrew the TCM 7 mm Jackscrew. Lift and remove the TCM from the MTM.

NOTICE: Do not allow contamination into the connectors on the TCM or MTM.



3. Inspect the TCM Seal for damage.

NOTICE: Replace the TCM Seal if damaged.

Note: If replacing the TCM, the REMAN TCM includes a new seal.



Remove the Mechatronic Transmission Module (MTM)

1. Lift the latch on the Output Speed Sensor Harness at the Connector on the Mechatronic Transmission Module (MTM).



2. Remove the Output Speed Sensor Harness from the Connector on the MTM.



3. Remove the 20 MTM cap screws.

Note: 13 mm (x18), 15 mm (x2).



4. Separate the MTM from the Main Housing at the 2 pry points.

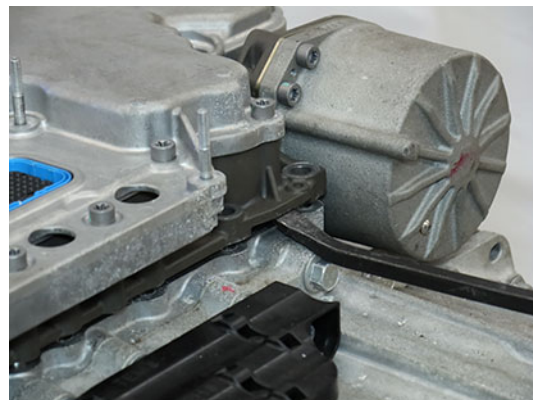

5. Remove the MTM from the transmission housing.

⚠ CAUTION: MTM weighs approximately 40 lbs. Keep fingers clear of pinch point between MTM and other surfaces. Dropping MTM could result in component damage and/or personal injury.



Remove the Output Speed Sensor

1. Remove the Output Speed Sensor Harness tie strap at the Harness Bracket.



2. Remove the 2 harness press-in retainers from the Main Housing and bracket on Rear Housing.



3. Remove the Output Speed Sensor 10 mm cap screw.



4. Remove the Output Speed Sensor from the Rear Housing.

Note: The sensor may need to be twisted and pulled from the bore.

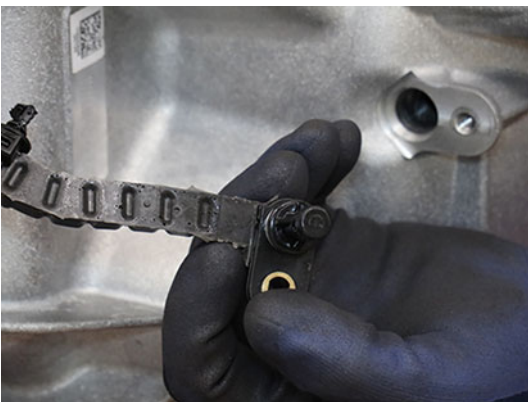
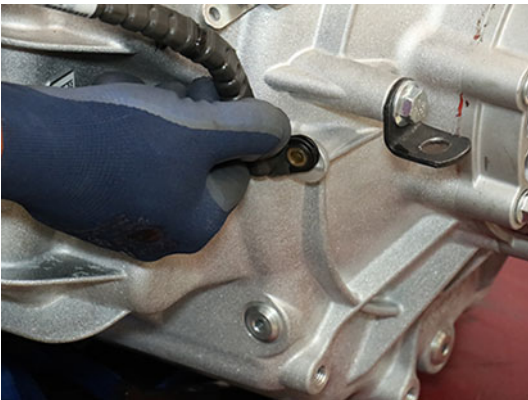

Remove the Harness Bracket

Note: This procedure contains removing the Harness Bracket without the Mechatronic Transmission Module (MTM).

1. Remove 3 Harness Bracket 10 mm cap screws.

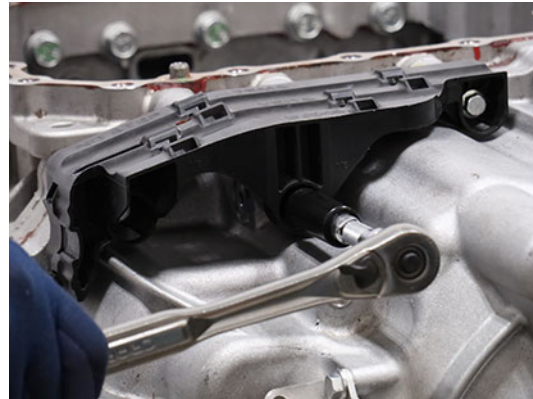

2. Remove Harness Bracket.



Secure Transmission (Vertical)

1. Place transmission in the vertical position with the front side down.



WARNING: Transmission weighs approximately 550 lbs. Keep fingers clear of pinch point between transmission and other surfaces. Dropping transmission may result in major vehicle component damage, severe injury or death.

NOTICE: Use an appropriate lifting device to safely lift component.

Note: Use a surface with an opening that allows the input shaft to pass through and the clutch housing to sit flat and secure.

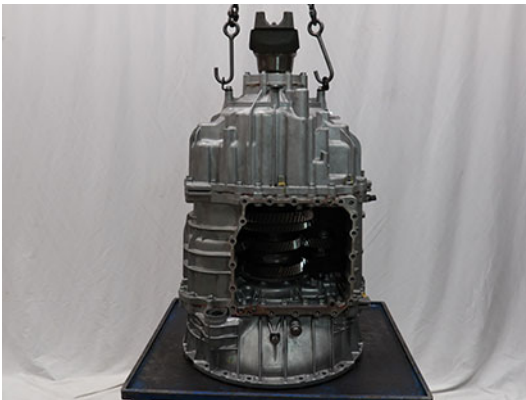
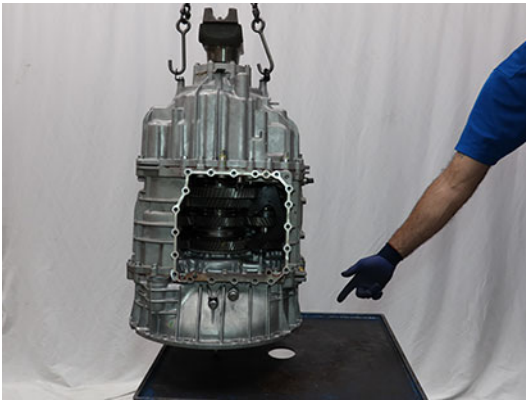

Remove the Rear Housing

1. At the 3 Rear Housing Threaded cap screws, apply paint marks on the Rear Housing to identify location.



2. Remove 21 Rear Housing and 3 threaded 16 mm cap screws.



3. Install and hand tighten 2 Rear Housing Alignment Pins (RR1090TR) 180-degrees apart.

NOTICE: Failure to install alignment pins results in transmission component damage.



4. Separate the Rear Housing from the Main Housing at the 2 pry points.



5. Lift and remove Rear Housing Assembly from Main Housing.



WARNING: Rear Housing Assembly weighs approximately 170 lbs. Failure to properly secure and lift the Rear Housing Assembly may result in major vehicle component damage, severe injury or death.

NOTICE: Use an appropriate lifting device to safely lift component.

Note: Dual PTO Transmissions are equipped with a rear PTO lube tube port on the pump and rear PTO drive splines on the Upper Countershaft.

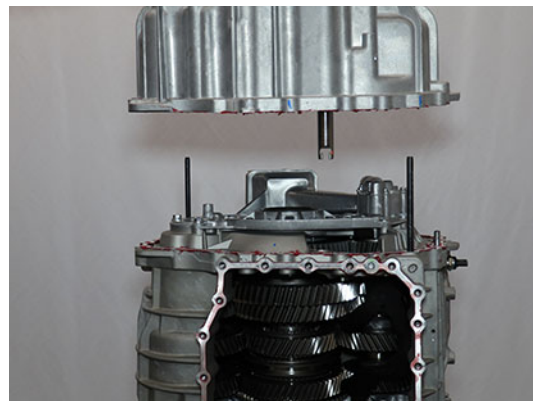

6. Place Rear Housing Assembly on bench.



WARNING: Rear Housing Assembly weighs approximately 170 lbs. Keep fingers clear of pinch point between Rear Housing Assembly and other surfaces. Dropping Rear Housing may result in major vehicle component damage, severe injury or death.

NOTICE: Support the Rear Housing Assembly to prevent damage to Shift Rail E.



7. Remove the 2 Rear Housing Alignment Pins (RR1090TR) from the Main Housing.

Remove the Oil Pump Assembly

1. Remove 18 Oil Pump Assembly 13 mm cap screws.



2. Remove Oil Pump Assembly.



3. Remove Oil Pump/Range Spacer with O-ring.



Remove Main Housing

1. Remove the 19 external and 6 internal Main Housing 16 mm cap screws.

NOTICE: To avoid internal transmission contamination, keep internal and external Main Housing cap screws separated.



2. Install and hand tighten 2 Rear Housing Alignment Pins (RR1090TR) in the internal Main Housing cap screw outer threaded holes.

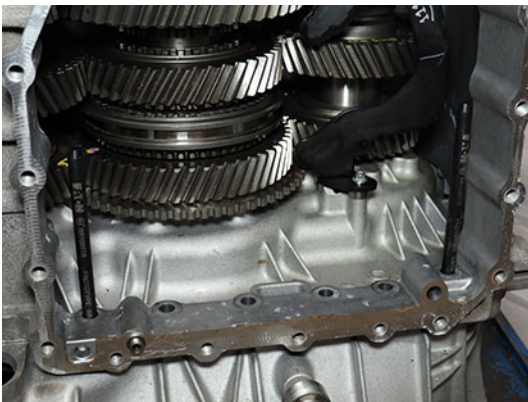

3. Remove 2 Rear Housing 90-degree Lifting Eye 15 mm cap screws from Rear Housing.



4. Install and hand tighten 2 Rear Housing 90-degree Lifting Eyes and 15 mm cap screws to Main Housing.

NOTICE: Do not over tighten cap screws.

Note: Install 90-degree Lifting Eyes 180-degrees apart to ensure even lifting.

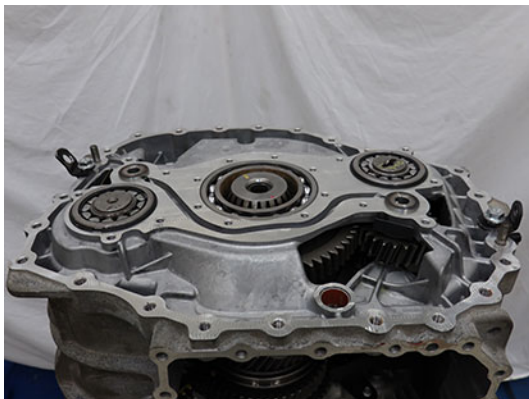

5. Separate Main Housing from Clutch Housing at the 2 pry points.



- Lift and remove Main Housing from Clutch Housing.



CAUTION: Main Housing weighs approximately 50 lbs. Keep fingers clear of pinch point between Main Housing and other surfaces. Dropping Main Housing could result in component damage and/or personal injury.

NOTICE: Use an appropriate lifting device to safely lift component.

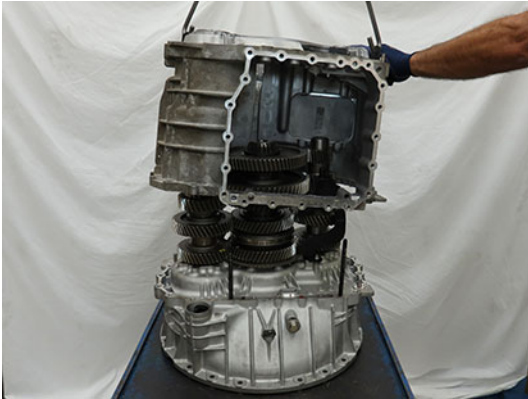

- Remove 2 Rear Housing Alignment Pins (RR1090TR).



- If Clutch Housing, Main Housing, Input Shaft, Input Shaft Bearing, or Main Shaft Bearing has been replaced, perform steps to **Install the Main Housing without Gasket Sealant** and measure Main Shaft End-Play. If these parts have NOT been replaced, perform steps to **Install Main Housing**.

Remove Main Shaft and Countershaft

- Remove the Upper Lube Tube 8 mm cap screw.



- Remove the Upper Lube Tube.



- Remove the Lower Lube Tube 8 mm cap screw.



4. Remove the Lower Lube Tube.



5. Install a magnet onto Main Shaft Key to ensure the key stays in place during Main Shaft Removal and Installation.



6. Hold Rail C Sliding Clutch against Secondary Driven Gear and lift Main Shaft from Primary Drive Gear.



CAUTION: Main Shaft weighs approximately 35 lbs. Keep fingers clear of pinch point between Main Shaft and other surfaces. Dropping Main Shaft could result in component damage and/or personal injury.

Note: Spring and Washer may remain attached to the Main Shaft during removal.



7. Remove Wave Spring - Rear.

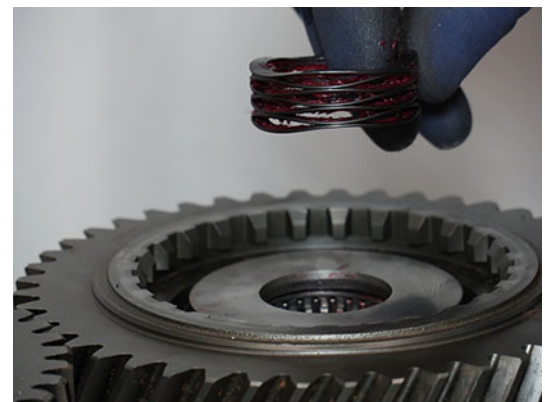

8. Remove Thrust Washer - Rear.



11. Remove Bearing Race - Rear.



9. Remove Thrust Bearing - Rear.



12. Remove Primary Drive Gear.



10. Remove Needle Bearing - Rear.



13. Remove Lower Countershaft.

- ⚠ CAUTION:** Countershaft weighs approximately 35 lbs. Keep fingers clear of pinch point between Countershaft and other surfaces. Dropping Countershaft could result in component damage and/or personal injury.



14. Remove Upper Countershaft.

- ⚠ CAUTION:** Countershaft weighs approximately 35 lbs. Keep fingers clear of pinch point between Countershaft and other surfaces. Dropping Countershaft could result in component damage and/or personal injury.



15. Remove Spherical Washer- Front.



16. Remove Bearing Race - Front.



17. Remove Needle Bearing - Front.

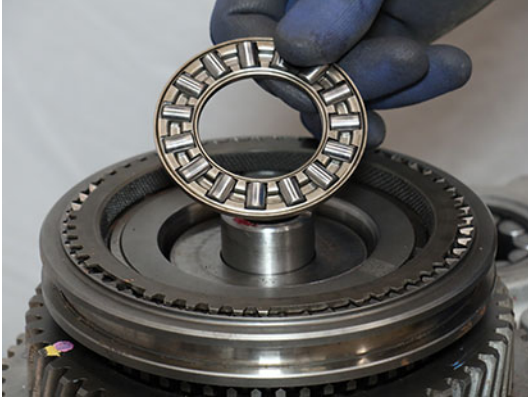

18. Remove Thrust Bearing - Front.**19. Remove Synchronizer Ring.****20. Slowly lift Synchronizer Sliding Sleeve up until Synchronizer Rollers are free from synchronizer assembly.**

NOTICE: Rollers are under spring pressure, ensure to slowly lift sleeve so rollers do not eject from the synchronizer assembly during disassembly.

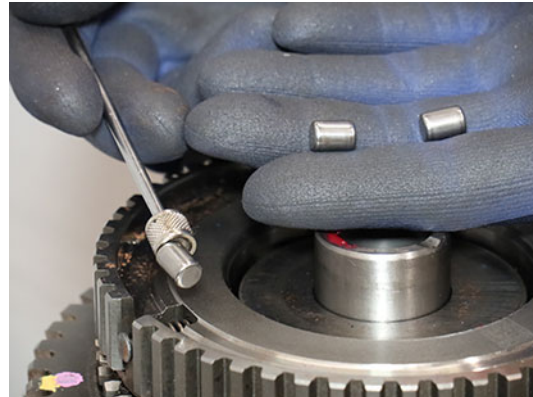
**21. Remove 3 Synchronizer Rollers.**

22. Remove 3 Synchronizer Plungers and Springs from Synchronizer hub.



23. Remove Thrust Washer - Front.



24. Remove Wave Spring - Front.

Note: If replacing Input Shaft, go to Input Shaft Disassembly/Assembly.



Install the Main Shaft and Countershaft

1. On the Secondary Drive Gear, apply paint marks on 2 gear teeth exactly 180-degrees across from each other, if not already marked.

Note: Paint marks are required for timing the Secondary Drive Gear to the Countershafts.



2. Install 3 springs and plungers into Synchronizer hub.

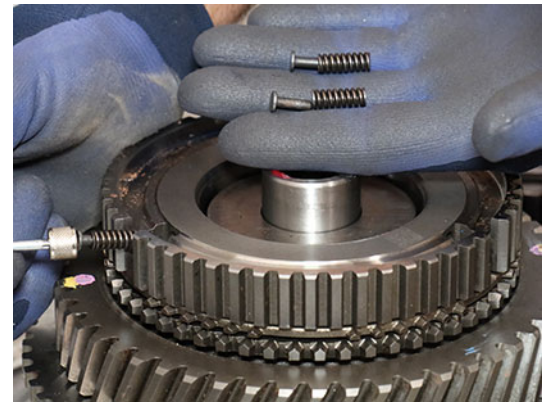

3. Install Rail B Synchronizer Sliding Sleeve with bevel facing up.

NOTICE: The tapered side of the sleeve is installed with the bevel facing up.



4. Lift and hold the Rail B Synchronizer Sliding Sleeve, install 3 rollers over the 3 springs and plungers and into the sliding sleeve groove.



5. Slowly press down the Synchronizer Sliding Sleeve to the neutral position and seat the 3 rollers evenly on the springs and plungers.

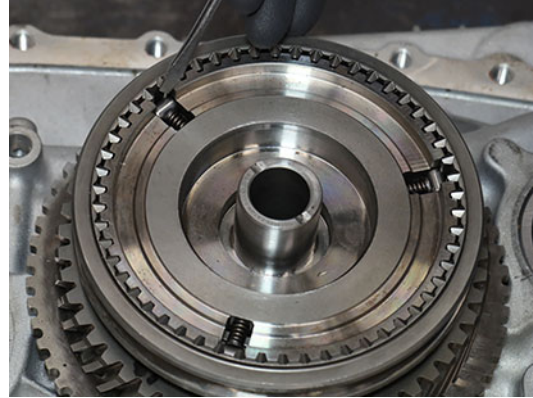

6. Install Rail B Synchronizer Ring.

Note: Align the 3 tabs on ring to the 3 openings on the hub at each spring and plunger.



7. Install Wave Spring - Front.

Note: Wave Spring - Front is taller than the Wave Spring - Rear.



8. Install Thrust Washer - Front.



9. Install Needle Bearing - Front.



10. Install Thrust Bearing - Front.



11. Install Bearing Race - Front.



12. Install Spherical Washer - Front with conical side down.



13. Install Lower Countershaft Pilot Tool (RR1071TR) to front section of Lower Countershaft.

Note: Lower Countershaft has Inertia Brake Splines on the front and Oil Pump drive slot on the rear.



14. On the Lower Countershaft front drive gear, apply paint marks on the 2 gear teeth marked "0 0".

NOTICE: If the Secondary Drive Gear and countershaft front drive gears are not paint marked correctly, the gearing will not be properly timed and the Main Housing cannot be installed due to countershaft misalignment.

Note: Paint marks are required for timing the Secondary Drive Gear to the Countershafts.

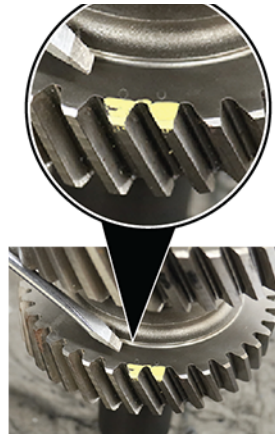

15. Install Lower Countershaft with Countershaft Pilot Tool (RR1071TR). Ensure timing marks align with Secondary Drive Gear and Lower Countershaft front drive gear.



CAUTION: Countershaft weighs approximately 35 lbs. Keep fingers clear of pinch point between Countershaft and other surfaces. Dropping Countershaft could result in component damage and/or personal injury.

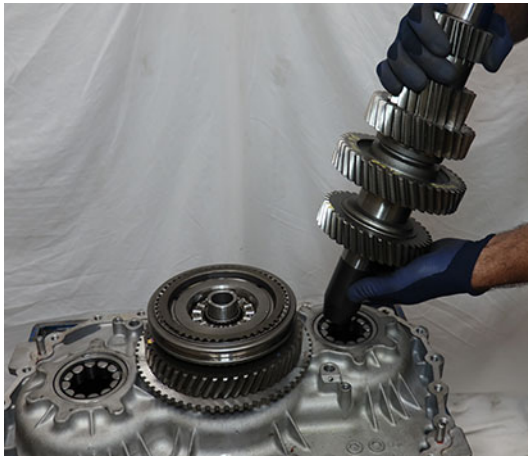

16. Install Upper Countershaft Pilot Tool (RR1072TR) to front section of Upper Countershaft.



17. On the Upper Countershaft front drive gear, apply paint marks on the 2 gear teeth marked "0 0".

NOTICE: If the Secondary Drive Gear and countershaft front drive gears are not paint marked correctly, the gearing will not be properly timed and the Main Housing cannot be installed due to countershaft misalignment.

Note: Paint marks are required for timing the Secondary Drive Gear to the Countershafts.

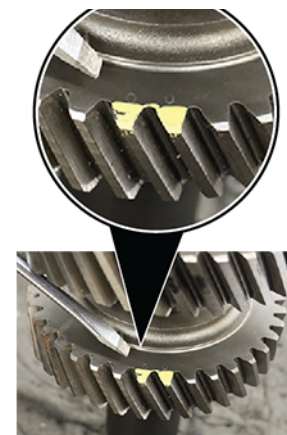

18. Install Upper Countershaft with Upper Countershaft Pilot Tool (RR1072TR) into bearing. Ensure timing marks align with Secondary Drive Gear and Upper Countershaft front drive gear.



CAUTION: Countershaft weighs approximately 35 lbs. Keep fingers clear of pinch point between Countershaft and other surfaces. Dropping Countershaft could result in component damage and/or personal injury.

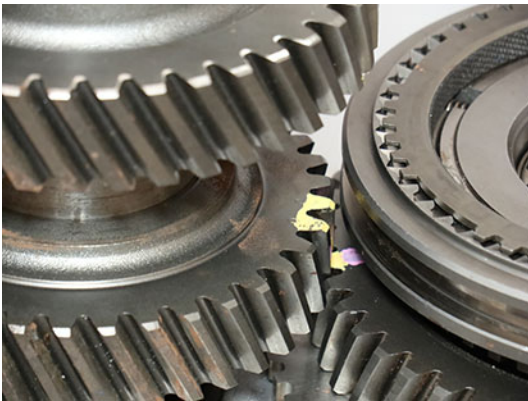

19. Install Primary Drive Gear with clutching teeth facing up onto Rail B Synchronizer.



20. Install Bearing Race - Rear.



21. Install Needle Bearing - Rear.



22. Install Thrust Bearing - Rear.



23. Apply transmission assembly lube to Wave Spring - Rear and install to Main Shaft.

NOTICE: Wave Spring - Rear is shorter than the Wave Spring - Front.

Note: Transmission assembly lube holds Wave Spring - Rear in place during Main Shaft Assembly installation.

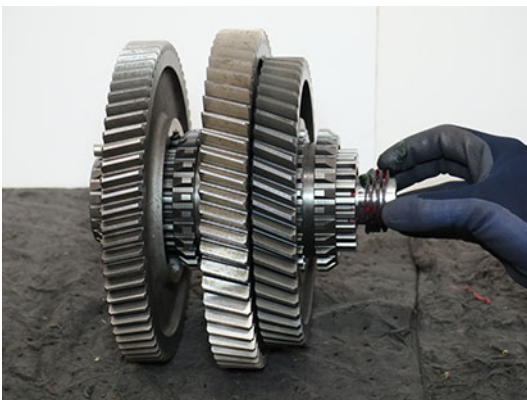

24. Apply transmission assembly lube to Thrust Washer - Rear and install to Main Shaft.

Note: Transmission assembly lube holds Thrust Washer - Rear in place during Main Shaft Assembly installation.



25. Install a magnet onto the Main Shaft Key.

Note: The magnet holds the key in position during Main Shaft Assembly installation.



26. Slide and hold Rail C Sliding Clutch into Secondary Driven Gear.



27. Install Main Shaft Assembly onto Primary Drive Gear and align gearing.



CAUTION: Main Shaft weighs approximately 35 lbs. Keep fingers clear of pinch point between Main Shaft and other surfaces. Dropping Main Shaft could result in component damage and/or personal injury.



28. Remove magnet from Main Shaft Key.

NOTICE: Ensure to remove magnet or component damage may occur during assembly.



29. Install Upper Lube Tube into Clutch Housing and install 8 mm cap screw and torque to 8–10 Nm (6–13 lb–ft).



30. Install Lower Lube Tube into Clutch Housing and 8 mm cap screw, torque to 8–10 Nm (6–13 lb–ft).

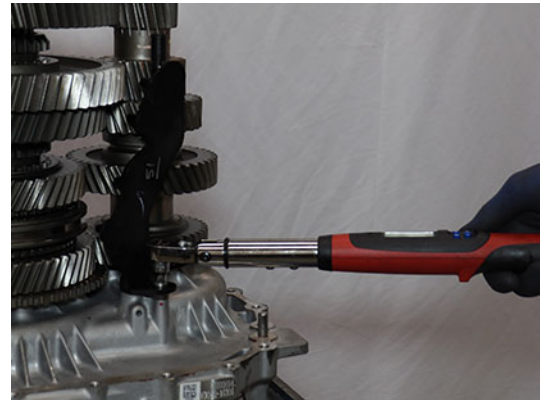

31. If Clutch Housing, Main Housing, Input Shaft, Input Shaft Bearing, or Main Shaft Bearing has been replaced, perform steps to Install the **Install the Main Housing without Gasket Sealant** before measuring and adjusting Main Shaft End-Play. If these parts have NOT been replaced, perform steps to **Install Main Housing**.

Install the Main Housing without Gasket Sealant

1. Clean the sealing surfaces on the Clutch Housing and Main Housing with gasket remover and a plastic scraper. Let air dry then wipe with a clean dry cloth.

NOTICE: Do not use abrasive scrapers or powered tools to clean sealing surfaces or sealing surfaces may be damaged and leak.

2. Inspect threaded bolt holes for debris and clean if necessary.

NOTICE: Ensure there is nothing in the threaded bolt holes or the transmission may be damaged when cap screws are tightened.

3. Slide O-ring over the Clutch Housing Inertia Brake air passage alignment pin until fully seated in groove.

NOTICE: Failure to install a new O-ring could result in degraded transmission performance.

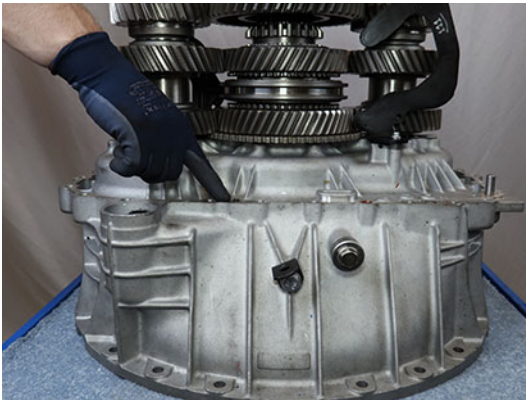

4. Install Lower Countershaft Pilot Tool (RR1071TR) onto Lower Countershaft above rear bearing race.



5. Install Upper Countershaft Pilot Tool (RR1072TR) onto the Upper Countershaft above rear bearing race.



6. Install and hand tighten 2 Rear Housing 90-degree Lifting Eyes and 15 mm cap screws to Main Housing.

NOTICE: Do not over tighten Lifting Eye cap screws.

Note: Install 90-degree Lifting Eyes 180-degrees apart to ensure even lifting.

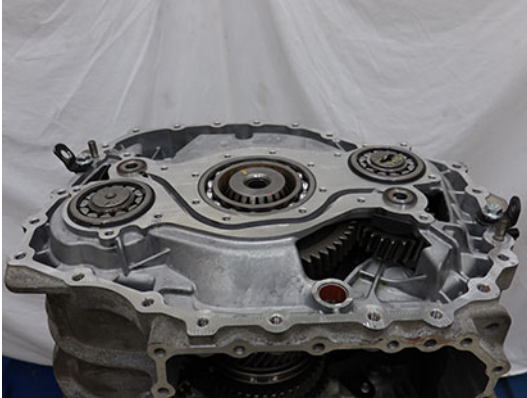

7. Install and hand tighten 2 Rear Housing Alignment Pins (RR1090TR) into the Clutch Housing as shown below.

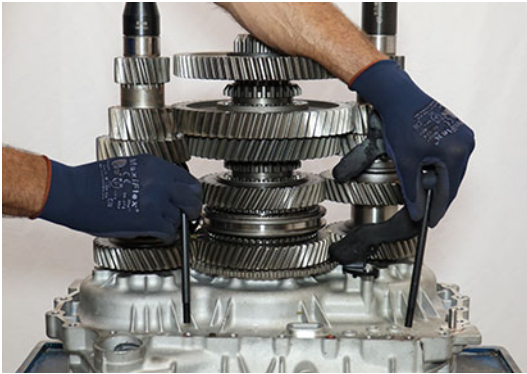

8. Lift, align and install Main Housing to Clutch Housing.



CAUTION: Main Housing weighs approximately 50 lbs. Keep fingers clear of pinch point between Main Housing and other surfaces. Dropping Main Housing could result in component damage and/or serious injury.

NOTICE: Use an appropriate lifting device to safely lift component.

Note: Using a flat tipped screwdriver, rotate the Reverse Idler Gears to align the gearing and allow Main Housing to fully seat onto the Clutch Housing.



9. Remove 2 Rear Housing Alignment Pins (RR1090TR).



10. Install 19 external and 6 internal Main Housing 16 mm cap screws and torque to 44–51 Nm (33–38 lb–ft) in a criss-cross pattern.

NOTICE: To avoid internal transmission contamination, keep internal and external Main Housing cap screws separated.

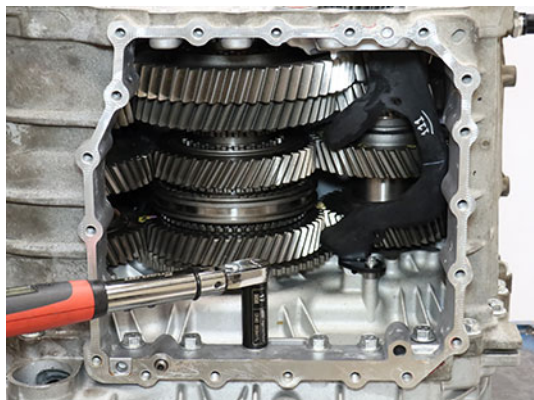

Measure and Adjust the Main Shaft End-Play

Note: The Main Shaft Selective Washer is available in 3 thicknesses: 6.525 mm (0.257 in), 6.712 mm (0.264 in) or 6.900 mm (0.272 in).

CAUTION: Ensure the Input Shaft Bearing and Main Shaft Bearing are seated in the Clutch Housing and Main Housing. Failure to fully seat bearings in housings will give an incorrect Main Shaft End-Play reading and may cause transmission component damage.

CAUTION: Ensure the 6.525 mm Main Shaft Selective Washer was installed. Only install a thicker selective washer after end-play has been measured and a thicker selective washer is required to achieve proper end-play or transmission damage may occur.

1. Install 4 Oil Pump 13 mm cap screws with flat washers (22.3 mm (0.9 in) minimum OD). Torque cap screws to 21-23 Nm (16-18 lb-ft).

Note: Flat washers are required to ensure the Main Shaft Bearing remains seated in the Main Housing during End-Play measurement.

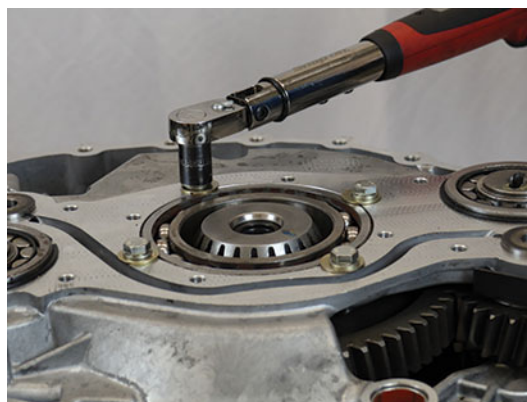

2. Thread a Dial Indicator mounting shaft into one of the inner Oil Pump mounting holes around the Main Shaft Bearing.

Note: The Oil Pump cap screw mounting holes thread pattern: M8 x 1.25 x 30 mm.



3. Mount the Dial Indicator to the shaft, set the plunger on the Main Shaft, and zero the Dial Indicator.

Note: Ensure that the Dial Indicator is vertical and zeroed for proper Main Shaft End-Play measurement.



4. Use two pry bars and slide them between the Reverse Gear and Main Housing at the locations shown below.

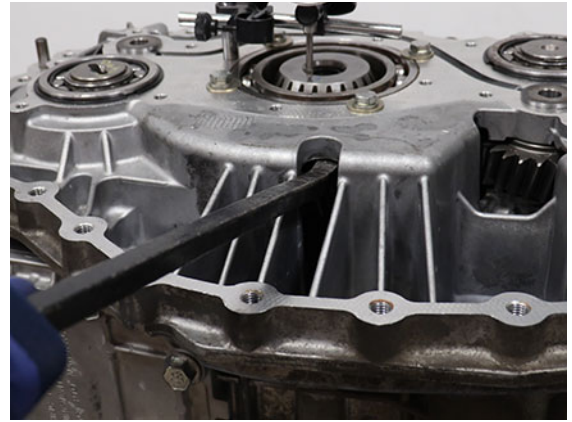

- Apply even downward pressure on Reverse Gear with both pry bars and monitor the Dial Indicator between the at-rest position of the Main Shaft and the point where no more downward movement is achieved. Record reading in table.

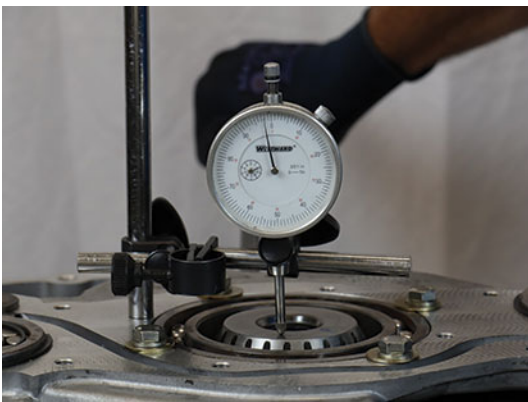
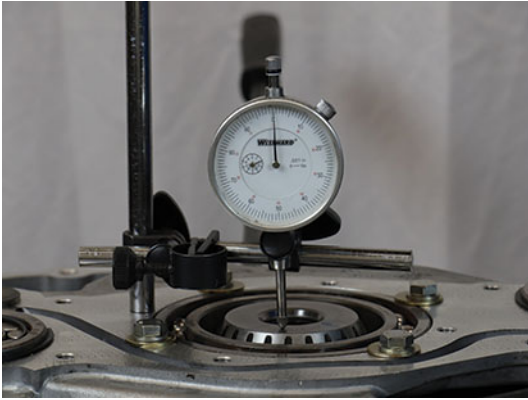

| |
|----------------------|
| Recorded End-Play |
| |

- Reference the Selective Main Shaft Washer Reference Chart and compare Recorded End-Play to reading in table.

Note: Main Shaft End-Play specification is 0.000-0.100 mm (0.000-0.004 in). The Selective Washer Chart is only valid for end-play measured with the 6.525 mm (0.257 in) selective washer installed.

- If end-play is in range, the installed Main Shaft Selective Washer, 6.525 mm (0.257 in), is correct.
- If end-play is out of range, determine the thicker ideal Main Shaft Selective Washer and record in table. Remove Main Shaft and install the Ideal Main Shaft Selective Washer.

Main Shaft Selective Washer Reference Chart

| Recorded End-Play | Ideal Main Shaft Selective Washer Thickness and Part Number |
|------------------------------------|---|
| 0.000-0.100 mm (0.000-0.004 in) | 6.525 mm (0.257 in) P/N 10000555 |
| 0.101-0.300 mm (0.005-0.011 in) | 6.712 mm (0.264 in) P/N 10001759 |
| 0.301-0.550 mm (0.012-0.021 in) | 6.900 mm (0.272 in) P/N 10001760 |

| |
|--------------------------------------|
| Ideal Main Shaft Selective Washer |
| |

CAUTION: Main Shaft End-Play must be remeasured after replacing Main Shaft Selective Washer or transmission component damage may occur.

Remove Main Housing

1. Remove the 19 external and 6 internal Main Housing 16 mm cap screws.

NOTICE: To avoid internal transmission contamination, keep internal and external Main Housing cap screws separated.



2. Install and hand tighten 2 Rear Housing Alignment Pins (RR1090TR) in the internal Main Housing cap screw outer threaded holes.

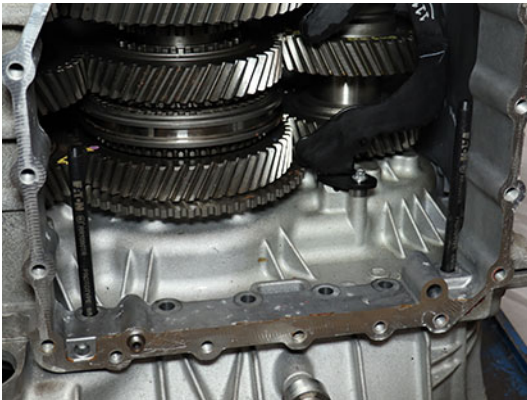

3. Separate Main Housing from Clutch Housing at the 2 pry points.

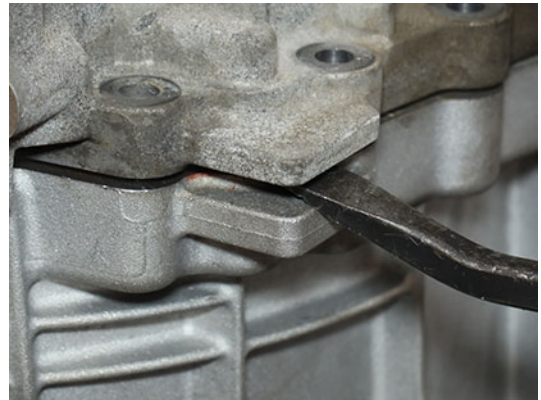

- Lift and remove Main Housing from Clutch Housing.



CAUTION: Main Housing weighs approximately 50 lbs. Keep fingers clear of pinch point between Main Housing and other surfaces. Dropping Main Housing could result in component damage and/or personal injury.

NOTICE: Use an appropriate lifting device to safely lift component.

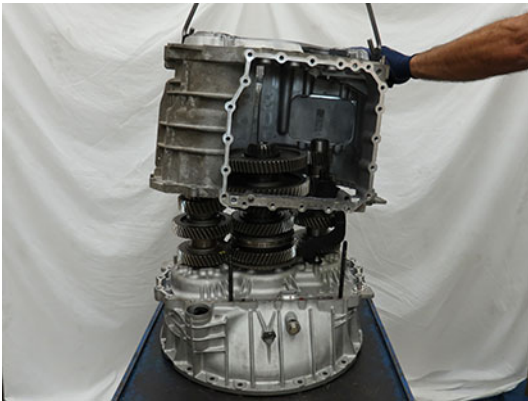

- Remove 2 Rear Housing Alignment Pins (RR1090TR).

Note: Applying sealer when installing Main Housing to Clutch Housing should only be done after proper Main Shaft End-Play has been verified.



- Reference the Selective Main Shaft Washer Reference Chart and compare Recorded End-Play to reading in table.

Note: Main Shaft End-Play specification is 0.000-0.100 mm (0.000-0.004 in). The Selective Washer Chart is only valid for end-play measured with the 6.525 mm (0.257 in) selective washer installed.

- If end-play is in range, the installed Main Shaft Selective Washer, 6.525 mm (0.257 in), is correct.
- If end-play is out of range, determine the thicker Ideal Main Shaft Selective Washer and record in table. Remove Main Shaft and install the Ideal Main Shaft Selective Washer.

Main Shaft Selective Washer Reference Chart

| Recorded End-Play | Ideal Main Shaft Selective Washer Thickness and Part Number |
|------------------------------------|---|
| 0.000-0.100 mm (0.000-0.004 in) | 6.525 mm (0.257 in) P/N 10000555 |
| 0.101-0.300 mm (0.005-0.011 in) | 6.712 mm (0.264 in) P/N 10001759 |
| 0.301-0.550 mm (0.012-0.021 in) | 6.900 mm (0.272 in) P/N 10001760 |

| Ideal Main Shaft Selective Washer |
|-----------------------------------|
| |



CAUTION: Main Shaft End-Play must be remeasured after replacing Main Shaft Selective Washer or transmission component damage may occur.

Disassemble the Main Shaft and Replace Main Shaft Selective Washer

Note: This procedure is only required if Main Shaft End-Play is out of range and a thicker Selective Washer is required.

1. Place Main Shaft Assembly horizontally on a clean flat surface.

CAUTION: Secure Main Shaft Assembly while on flat surface to avoid unexpected movement. Failure to properly secure Main Shaft Assembly could result in component damage and/or personal injury.

2. Remove Rail C Sliding Clutch.

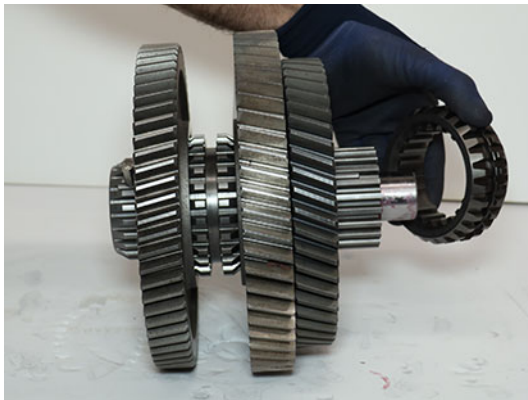

3. Place Main Shaft assembly vertically on a clean flat surface.

CAUTION: Secure Main Shaft Assembly while on flat surface to avoid unexpected movement. Failure to properly secure Main Shaft Assembly could result in component damage and/or personal injury.



4. Remove Main Shaft Key while inserting 5/32 OD air line.



5. Rotate and remove the Main Shaft Selective Washer above Reverse Gear.

Note: The Main Shaft Selective Washer above Reverse Gear is available in 3 thicknesses; 6.525, 6.712 or 6.900 mm to control Main Shaft End-Play.



Assemble and Install the Main Shaft with Replaced Main Shaft Selective Washer

1. Install and rotate the Ideal Main Shaft Selective Washer above Reverse Gear recorded in Step 6 of the Main Shaft End-Play Service Procedure.

Note: The Main Shaft Selective Washer is available in 3 thicknesses: 6.525, 6.712 or 6.900 mm.



2. Slide the 5/32 OD air line up to align and hold washer in place.



3. Install Main Shaft Key at the same spline as the 5/32 OD air line.

Note: Insert Main Shaft Key while removing air line.



4. Install a magnet on Main Shaft Key to hold the key in place during final Main Shaft Assembly and installation into transmission.

Note: Remove magnet from Main Shaft Key after installation of Main Shaft Assembly onto transmission.



5. Place Main Shaft Assembly horizontally on a clean flat surface.



CAUTION: Secure Main Shaft Assembly while on flat surface to avoid unexpected movement. Failure to properly secure Main Shaft Assembly could result in component damage and/or personal injury.

6. Install Rail C Sliding Clutch and align the double slot with Main Shaft Key.

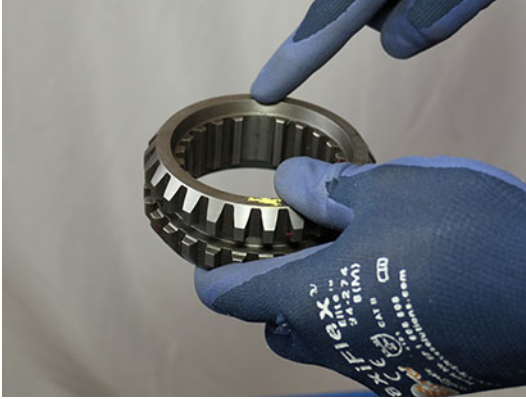

7. Apply transmission assembly lube to Wave Spring - Rear and install to Main Shaft.

NOTICE: Wave Spring - Rear is shorter than the Wave Spring - Front.

Note: Transmission assembly lube holds Wave Spring - Rear in place during Main Shaft Assembly installation.



8. Apply transmission assembly lube to Thrust Washer - Rear and install to Main Shaft.

Note: Transmission assembly lube holds Thrust Washer - Rear in place during Main Shaft Assembly installation.



9. Install a magnet onto the Main Shaft Key.

Note: The magnet holds the key in position during Main Shaft Assembly installation.



10. Slide and hold Rail C Sliding Clutch into Secondary Driven Gear.



11. Install Main Shaft Assembly onto Primary Drive Gear and align gearing.



CAUTION: Main Shaft weighs approximately 35 lbs. Keep fingers clear of pinch point between Main Shaft and other surfaces. Dropping Main Shaft could result in component damage and/or personal injury.



12. Remove magnet from Main Shaft Key.

NOTICE: Ensure to remove magnet or component damage may occur during assembly.



13. If removed, install Upper Lube Tube into Clutch Housing and install 8 mm cap screw and torque to 8–10 Nm (6–13 lb–ft).



14. If removed, install Lower Lube Tube into Clutch Housing and 8 mm cap screw, torque to 8–10 Nm (6–13 lb-ft).

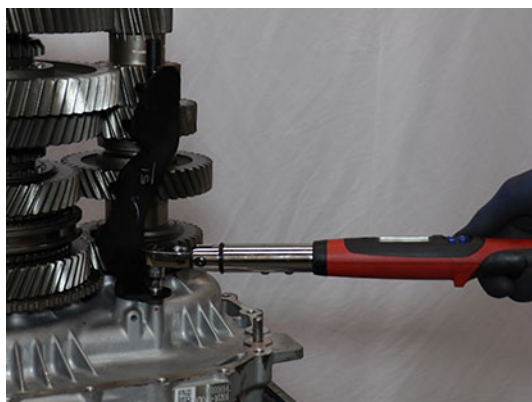

15. Perform steps to **Install the Main Housing without Gasket Sealant** and remeasure Main Shaft End-Play.



CAUTION: Main Shaft End-Play must be remeasured after replacing Main Shaft Selective Washer or transmission component damage may occur.

Install Main Housing

1. Clean the sealing surfaces on the transmission Main Housing and Rear Housing with gasket remover and a plastic scraper. Let air dry then wipe with a clean dry cloth.

NOTICE: Do not use abrasive scrapers or powered tools to clean sealing surfaces or sealing surfaces may be damaged and leak.

2. Inspect threaded bolt holes for debris and clean if necessary.

NOTICE: Ensure there is nothing in the threaded bolt holes or the transmission may be damaged when cap screws are tightened.

3. Slide O-ring over the Clutch Housing Inertia Brake air passage alignment pin until fully seated in groove.



4. Apply gasket sealant with a bead width of 1.4-2.4 mm (0.055-0.094 inch) to clutch housing as shown in pattern below.

NOTICE: Ensure there is nothing in the threaded bolt holes or the transmission may be damaged when cap screws are tightened.

Note: Parts must be assembled within 10 minutes of applying gasket sealant.

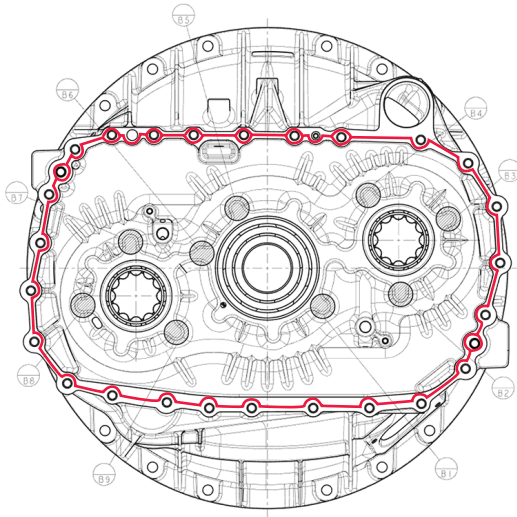

5. Install Lower Countershaft Pilot Tool (RR1071TR) onto Lower Countershaft above rear bearing race.



6. Install Upper Countershaft Pilot Tool (RR1072TR) onto the Upper Countershaft above rear bearing race.



7. Install and hand tighten 2 Rear Housing 90-degree Lifting Eyes and 15 mm cap screws to Main Housing.

NOTICE: Do not over tighten Lifting Eye cap screws.

Note: Install 90-degree Lifting Eyes 180-degrees apart to ensure even lifting.



8. Install and hand tighten 2 Rear Housing Alignment Pins (RR1090TR) into the Clutch Housing as shown below.

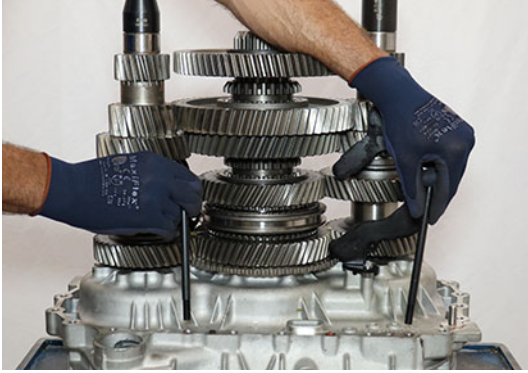

9. Lift, align and install Main Housing to Clutch Housing.



CAUTION: Main Housing weighs approximately 50 lbs. Keep fingers clear of pinch point between Main Housing and other surfaces. Dropping Main Housing could result in component damage and/or serious injury.

NOTICE: Use an appropriate lifting device to safely lift component.

Note: Using a flat tipped screwdriver, rotate the Reverse Idler Gears to align the gearing and allow Main Housing to fully seat onto the Clutch Housing.



10. Remove 2 Rear Housing Alignment Pins (RR1090TR).



11. Remove 2 Rear Housing 90-degree Lifting Eyes and 15 mm cap screws from Main Housing.

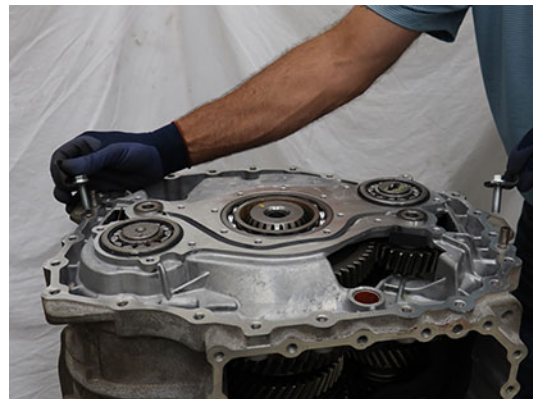

12. Re-install 2 Rear Housing 90-degree Lifting Eyes to the Rear Housing and torque to 49.6-55.5 Nm (36-40 lb-ft).



13. Install 19 external and 6 internal Main Housing 16 mm cap screws and torque to 44-51 Nm (33-38 lb-ft) in a criss-cross pattern.

NOTICE: To avoid internal transmission contamination, keep internal and external Main Housing cap screws separated.

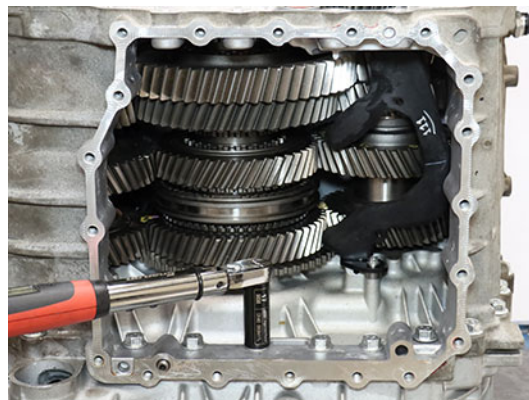

Install the Oil Pump Assembly

1. Install O-ring to the Oil Pump/Range Spacer.



2. Install Oil Pump/Range Spacer with O-ring and align tab with groove in Oil Pump Assembly.

NOTICE: Ensure the spacer tab is aligned with the groove and the spacer sits flush in the Oil Pump Assembly.



3. While holding the Oil Pump/Range Spacer in place, align oil pump drive key with slot on Lower Countershaft and install Oil Pump Assembly to Main Housing.



CAUTION: Failure to properly install the Oil Pump/Range Spacer and align the oil pump drive key results in transmission component damage during Oil Pump Assembly installation.

NOTICE: Ensure oil pump drive key is aligned with counter shaft drive slot during Oil Pump Assembly installation.



4. Press Oil Pump Assembly to ensure it sits flat on Main Housing sealing surface.



5. Install 18 Oil Pump Assembly 13 mm cap screws and torque to 21–23 Nm (16–18 lb–ft) in a criss-cross pattern.

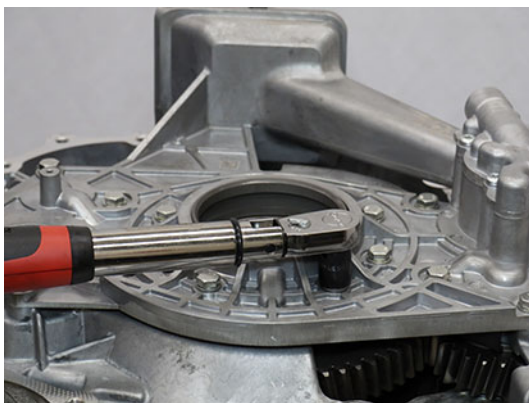

Install the Rear Housing

1. Clean the sealing surfaces on the transmission Main Housing and Rear Housing with gasket remover and a plastic scraper. Let air dry then wipe with a clean dry cloth.

NOTICE: Do not use abrasive scrapers or powered tools to clean sealing surfaces or sealing surfaces may be damaged and leak.
2. Inspect threaded bolt holes for debris and clean if necessary.
3. Apply Gasket Sealant with a bead width of 1.4-2.4 mm (0.055-0.094 inch) to the transmission Main Housing sealing surface following the pattern below.

NOTICE: Ensure there is nothing in the threaded bolt holes or the transmission housing may be damaged when cap screws are tightened.

Note: Parts must be assembled within 10 minutes of applying Gasket Sealant.

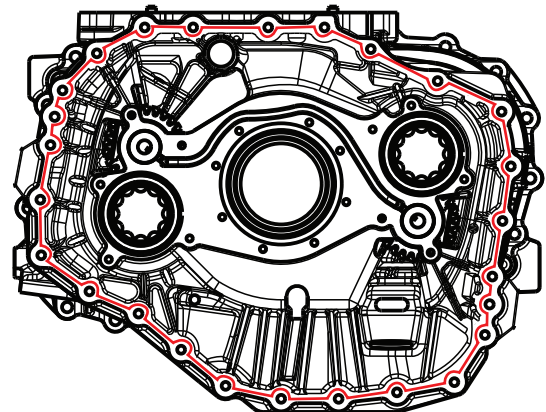

4. Install and hand tighten 2 Rear Housing Alignment Pins (RR1090TR) 180-degrees apart.



CAUTION: Failure to install alignment pins results in transmission component damage during Rear Housing Assembly installation.

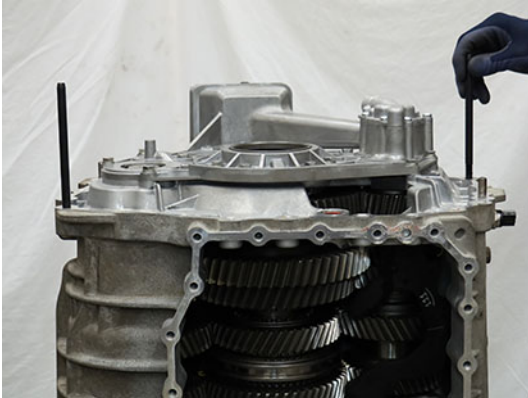

6. Install the 3 Rear Housing Threaded 16 mm cap screws at the 3 paint mark locations.

Note: Two cap screws are used to mount the harness bracket and the third is used by the OEM for additional attachment points.



5. Lift and install the Rear Housing Assembly on to the Main Housing.



WARNING: Rear Housing Assembly weighs approximately 170 lbs. Failure to properly secure and lift the Rear Housing may result in major vehicle component damage, severe injury or death.

NOTICE: Use an appropriate lifting device to safely lift component.

Note: Align the Rear Housing to the alignment pins and align Shift Rail E into the Main Housing during installation.

Note: Rotate Output Shaft to align gearing and allow Rear Housing Assembly to fully seat on Main Housing.



7. Remove the 2 Rear Housing Alignment Pins (RR1090TR).

8. Install the remaining 21 Rear Housing 16 mm cap screws and torque to 44.5 - 51.5 Nm (33-38 lb-ft) in a criss-cross pattern.



9. Lift transmission horizontally onto a bench.



WARNING: Transmission weighs approximately 550 lbs. Keep fingers clear of pinch point between transmission and other surfaces. Dropping transmission may result in major vehicle component damage, severe injury or death.

NOTICE: Use an appropriate lifting device to safely lift component.

Secure Transmission (Horizontal)

1. Securely place transmission in the horizontal position with the front side down.



WARNING: Transmission weighs approximately 550 lbs. Keep fingers clear of pinch point between transmission and other surfaces. Dropping transmission may result in major vehicle component damage, severe injury or death.

NOTICE: Use an appropriate lifting device to safely lift component.

Install Lower Countershaft Snap Ring and Flat Washer

1. Install Lower Countershaft Flat Washer and Snap Ring.

NOTICE: A new snap ring is required when reinstalling. A used snap ring may detach from Countershaft and result in transmission component damage.



Install the Lower Countershaft Cover and Inertia Brake

1. Clean sealing surfaces on the Clutch Housing and Inertia Brake Housing.
2. Install the Inertia Brake Cover and Housing as an assembly over the Lower Countershaft, rotate the assembly to align the Friction Discs to the Lower Countershaft splines and seat the assembly to the clutch housing.

Note: Reference "RRMT0027 - Clutch Housing Front Cover Kit" on page 586 for new Inertia Brake Housing part number, additional O-ring part number, and installation instructions.

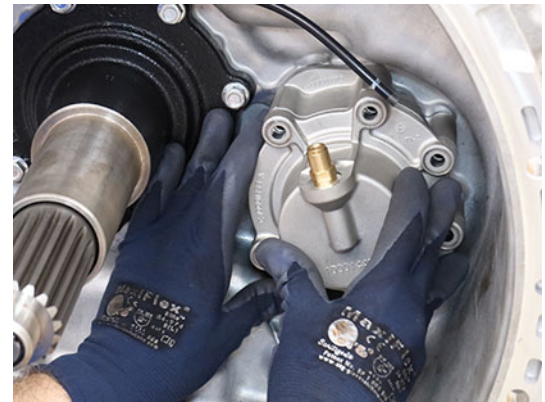

3. While holding the Inertia Brake Housing to the clutch housing, remove the Inertia Brake Cover.

NOTICE: Ensure the Friction Discs are splined to the lower countershaft and Wear Guides are fully seated.



4. Install the Return Spring into the Lower Countershaft.



5. Install the Piston Pin into the Lower Countershaft.



6. Install the Inertia Brake Cover onto the housing.

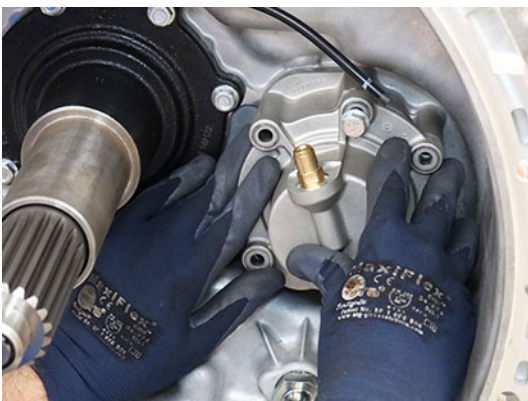

7. Install the 6 13 mm cap screws and torque to 21-25 Nm (16-19 lb-ft) in a criss-cross pattern.



8. Insert air line in push-to-connect fitting on the Inertia Brake Cover.



Install Upper Countershaft Snap Ring and Flat Washer

1. Install Upper Countershaft Flat Washer and Snap Ring.

NOTICE: A new snap ring is required when reinstalling. A used snap ring may detach from countershaft and result in transmission component damage.



Install the Upper Countershaft Cover

1. Clean the sealing surfaces on the clutch housing and the Upper Countershaft Cover.

Note: A new Upper Countershaft Cover Seal is required when reinstalling or an oil leak may occur. Reference "RRMT0027 - Clutch Housing Front Cover Kit" on page 586 for new Upper Countershaft Cover part number, additional O-ring part number, and installation instructions.

2. Insert the Upper Countershaft Cover Seal into the groove until fully seated.



3. Install the Upper Countershaft Cover to the Clutch Housing.

4. Install the six 13 mm cap screws and torque to 21-25 Nm (16-19 lb-ft) in a criss-cross pattern.



Install the Harness Bracket

Note: This procedure contains installing the Harness Bracket without the Mechatronic Transmission Module (MTM).

1. Install Harness Bracket.



2. Install 3 Harness Bracket 10 mm cap screws and torque to 8.8 - 10.4 Nm (6-8 lb-ft).



Install the Output Speed Sensor

1. Clean the sensor bore.

NOTICE: Do not use abrasive scrapers or powered tools to clean sealing surface.

2. Apply a light coat of transmission oil to the sensor O-ring.
3. Install the Output Speed Sensor into the bore.

Note: The Sensor may need to be twisted and pushed into the bore.



4. Install the Output Speed Sensor 10 mm cap screw and torque to 8.8-10.4 Nm (6-8 lb-ft).



5. Press the 2 harness press-in retainers into the Main Housing and the bracket on the rear housing.



6. Secure the Output Speed Sensor Harness to the Harness Bracket with a tie strap.



CAUTION: Failure to tie strap the Output Speed Sensor Harness to the Harness Bracket may result in harness damage.

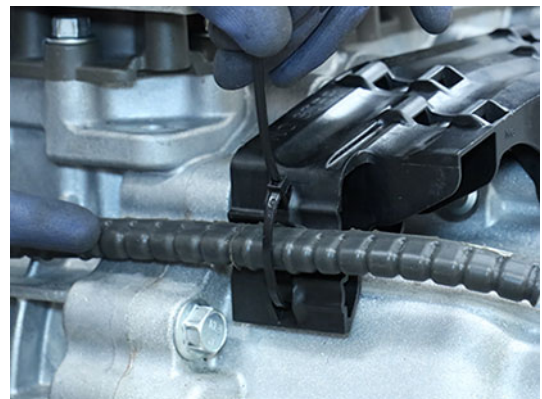

Install the Mechatronic Transmission Module (MTM)

Note: If replacing original equipment MTM with new/replacement MTM locate new/replacement MTM part information tag and record Part Number and Serial Number. Refer to Component Identification section. Part Number and Serial Number are required to properly configure TCM after MTM installation.

1. Place the transmission in a horizontal position.

NOTICE: The transmission must be in a horizontal position prior to the MTM Installation procedure. Failure to do so causes the sliding clutches to move out of neutral and not align to the shift yokes. If the shift yokes are not aligned to the sliding clutches, position sensor fault codes set Active and the transmission will not shift out of neutral.

2. Clean the sealing surfaces on the transmission and Mechatronic Transmission Module (MTM) with gasket remover and a plastic scraper. Let air dry then wipe with a clean dry cloth.

NOTICE: Do not use abrasive scrapers or powered tools to clean sealing surfaces or sealing surfaces may be damaged and leak.

3. Inspect threaded bolt holes for debris and clean if necessary.

NOTICE: Ensure there is nothing in the threaded bolt holes or the transmission may be damaged when cap screws are tightened.

4. Install the Rail B Engagement Tool (RR1088TR) to the Main Housing and hand tighten with 2 MTM cap screws.



5. Shift the Rail B Synchronizer to neutral.

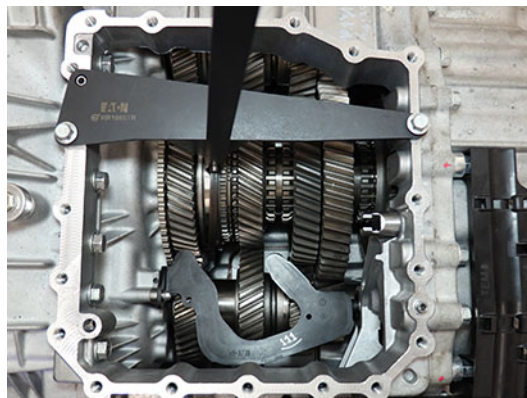

6. Remove the Rail B Engagement Tool.
7. Move Rail C and Rail D sliding clutches to neutral.

NOTICE: The transmission must be in a horizontal position prior to the MTM Installation procedure. Failure to do so causes the sliding clutches to move out of neutral and not align to the shift yokes. If the shift yokes are not aligned to the sliding clutches, position sensor fault codes set Active and the transmission will not shift out of neutral.

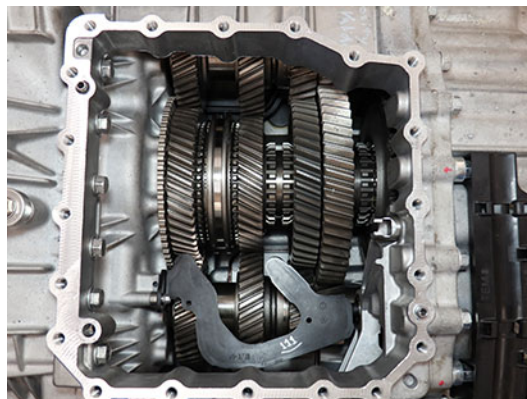

8. Install the Confirm-Neutral Gauge (RR1086TR-2) into the slots of the synchronizer and sliding clutches.

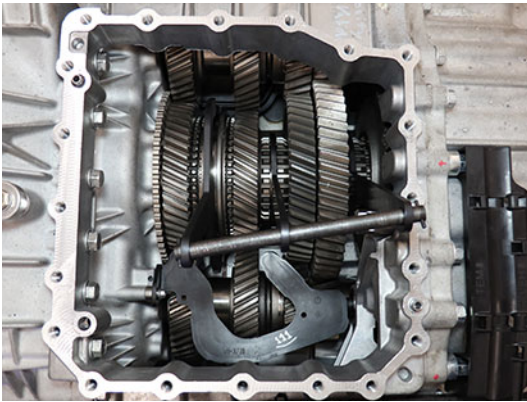

9. Install the MTM Alignment Tool (RR1086TR-1) onto the main housing.

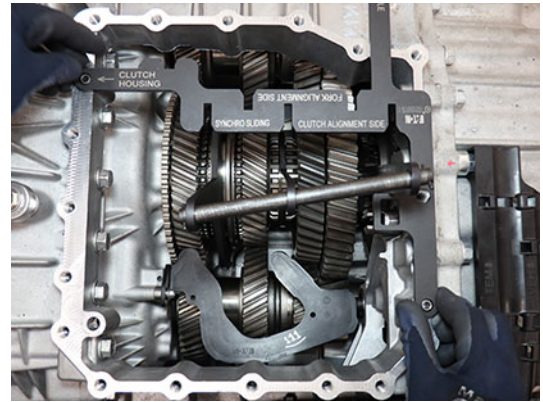
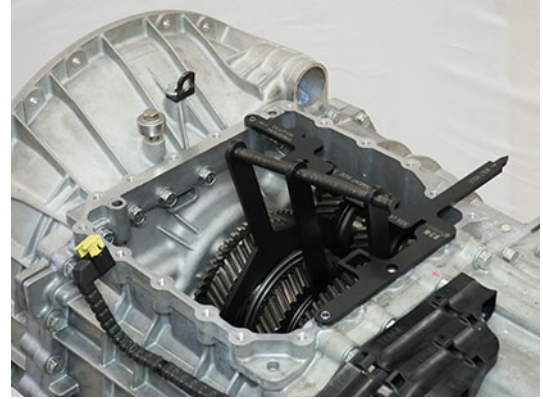

10. Verify synchronizer and sliding clutches are in neutral by sliding Confirm-Neutral Gauge into the slots of MTM Alignment Tool.

Note: If the gauge does not slide into the alignment tool slots, neutral is not achieved. Go to Step 4.



11. Using the Rail E Lever, move Rail E to neutral.

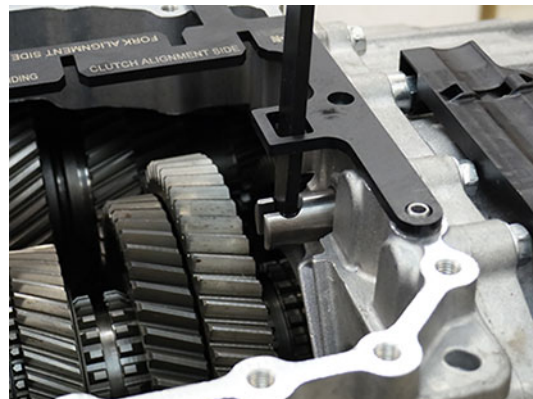
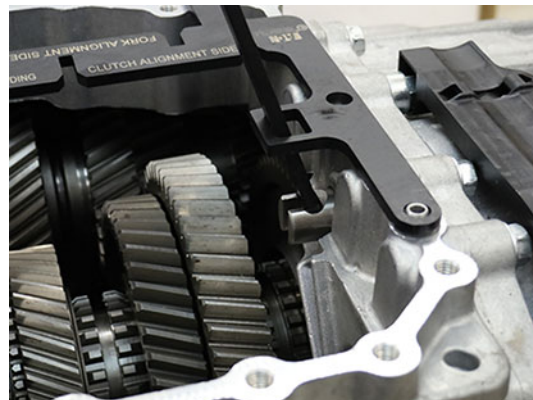
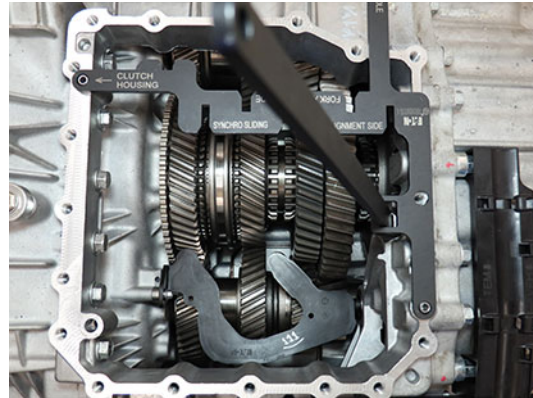

- 12.** Verify Rail E is in neutral using the Gear Side Actuator end of the Confirm-Neutral Gauge (RR1088TR-2) at Shift Rail E. Rail E is in neutral when end of gauge rests against housing with rail against notch-end of gauge.

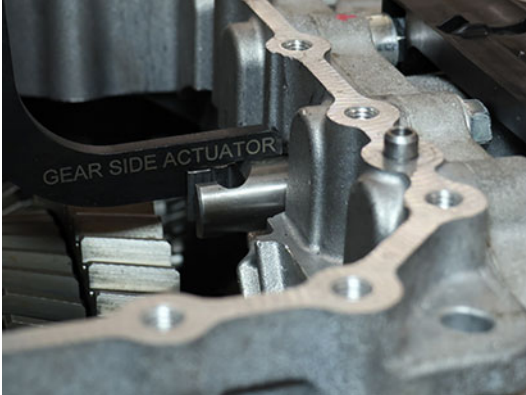

- 13.** Move Shift Rail B in the MTM to neutral. Rail B is in neutral when the ball detent is in the notch of the Rail B yoke assembly.

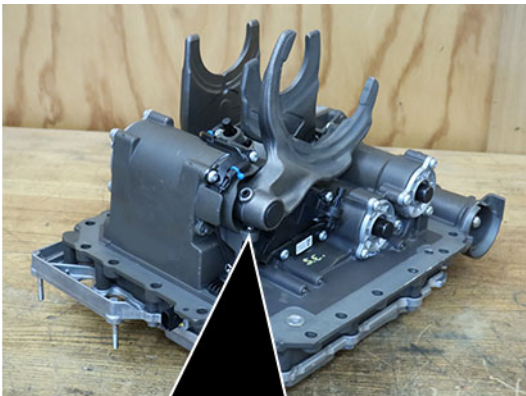

- 14.** Move Shift Rails C and D in the MTM to neutral. Rails C and D are in neutral when the shift inter-lock is aligned with the notches of the rail yoke assemblies.

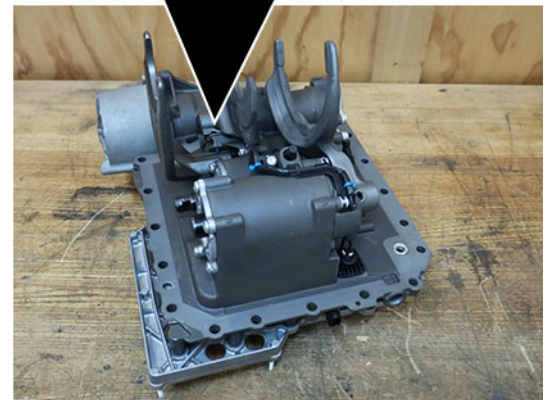
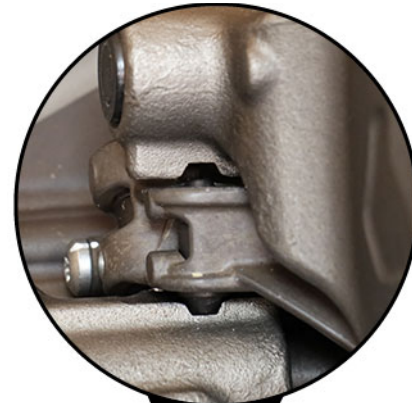

- Verify MTM is in neutral. Install the MTM Alignment Tool (RR1086TR-1) into the bolt hole and onto Rail B, C, and D Shift Yokes.

Note: If the MTM Alignment Tool slots do not align with the 3 shift yokes, neutral has not been achieved. Go to Step 13.



- Verify notch on Rail E is facing up.

Note: If MTM is installed on transmission with notch on Rail E facing down, Fault Code/SPN 320/5942 sets Active and transmission does not shift out of neutral.

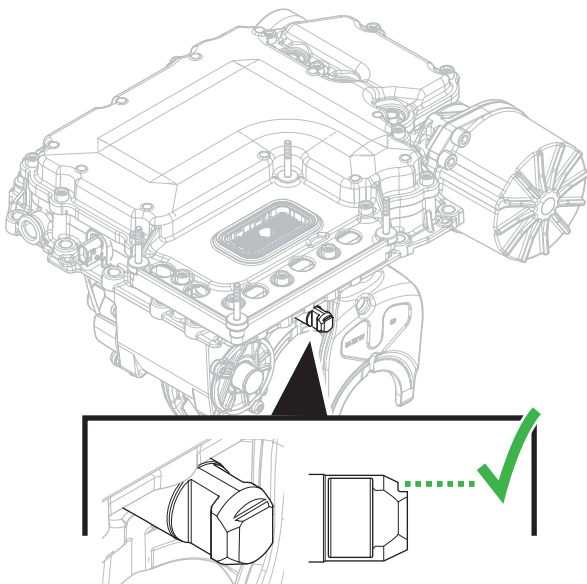

- Verify Rail E is in neutral using the Fork Side Actuator end of the Confirm-Neutral Gauge (RR1088TR-2) at Shift Rail E. Rail E is in neutral when end of gauge rests against cover with rail against notch-end of gauge.

Note: If Rail E is not in neutral, slide rail in or out until neutral is achieved.



- Slide O-ring over the MTM front alignment pin on the main housing until fully seated in the groove.

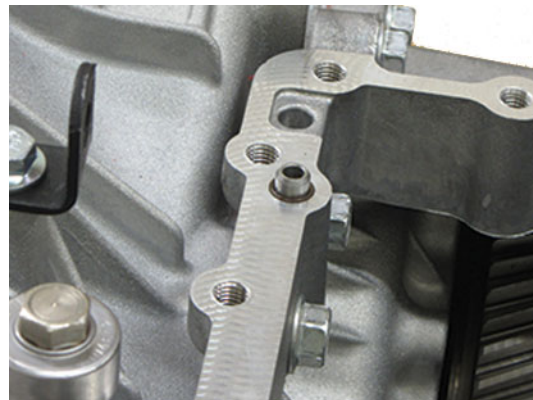

19. Clean the sealing surfaces on the transmission and Mechatronic Transmission Module (MTM) with gasket remover and a plastic scraper. Let air dry then wipe with a clean dry cloth.

NOTICE: Do not use abrasive scrapers or powered tools to clean sealing surfaces or sealing surfaces may be damaged and leak.

20. Apply gasket sealant with a bead width of 1.4-2.4mm (0.055-0.094 inch) to the transmission housing sealing surface following the pattern below.

NOTICE: Ensure there is nothing in the threaded bolt holes or the transmission may be damaged when cap screws are tightened.

Note: Parts must be assembled within 10 minutes of applying Gasket Sealant.

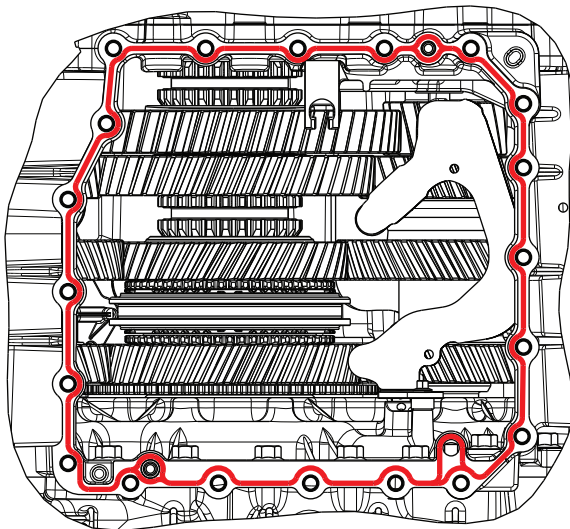

21. Install MTM onto the transmission housing. Align Rail E in the MTM with the Rail E Shift Rail in the Main Housing.

CAUTION: MTM weighs approximately 40 lbs. Keep fingers clear of pinch point between MTM and other surfaces. Dropping MTM could result in component damage and/or personal injury.

NOTICE: If the MTM is installed on the transmission and Rail E in the MTM is not aligned with Rail E in the Main Housing, Fault Code 320 (SPN 5942) sets Active and the transmission will not shift out of neutral.

22. Install 20 MTM cap screws and torque to 44.5-51.5 Nm (33-38 lb-ft) in a criss-cross pattern.

Note: 13 mm (x18), 15 mm (x2) cap screws.



Install the Transmission Control Module (TCM)

NOTICE: Do not allow contamination into the connectors on the TCM or MTM.

Note: TCM can be installed with transmission in-vehicle.

1. Install the TCM Seal on the 74-Way Harness Connector.



2. Align the TCM to the 74-Way Harness Connector and TCM studs, then install the TCM.

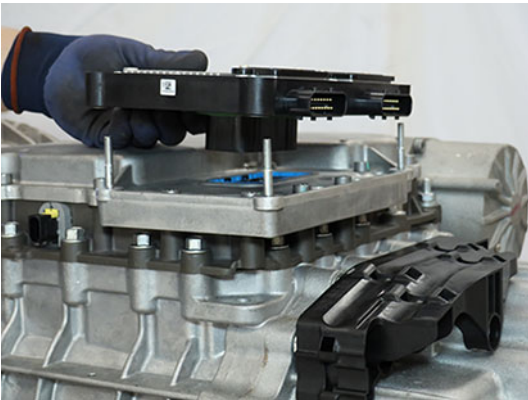

3. Torque the TCM 7 mm Jackscrew to 3.0-4.0 Nm (26.6-35.4 lb-in).

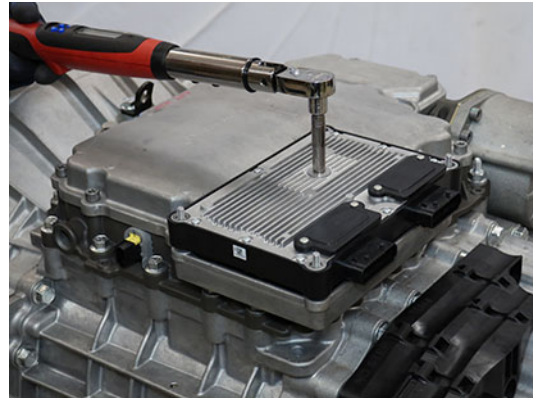

4. Install the TCM Cover over the 4 TCM studs and torque the 4 TCM Cover Nuts to 8.8-10.4 Nm (78-92 lb-in) in a criss-cross pattern.

Note: TCM Cover nuts are 10 or 13 mm.

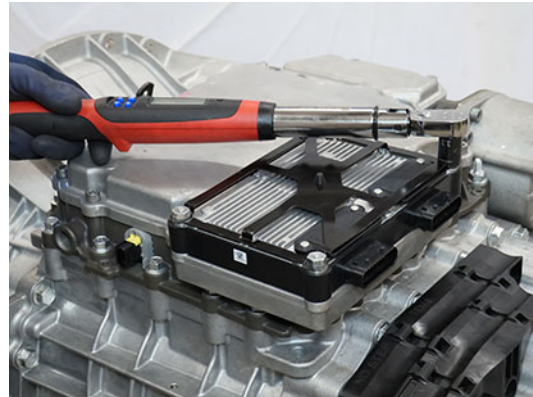

Remove the Linear Clutch Actuator (LCA)

1. Loosen the 4 LCA cap screws 1-2 turns each with a T45 Torx.

NOTICE: Ensure key is off, 20-Way TCM Vehicle and Body Harness Connectors are disconnected, and 5 minutes has passed prior to LCA removal.

Note: Residual air pressure in the LCA cylinder exhausts between the LCA and MTM housing when the cap screws are loosened.



2. Remove the 4 LCA cap screws
3. Remove the LCA from the MTM.

Note: LCA piston rod end is seated in the release yoke socket; pull to release rod end from socket.



4. Inspect the plastic socket insert in the release yoke through the LCA opening using a flashlight to verify none of the fingers are missing or damaged.

Note: If the plastic insert is damaged, replace the release yoke assembly.

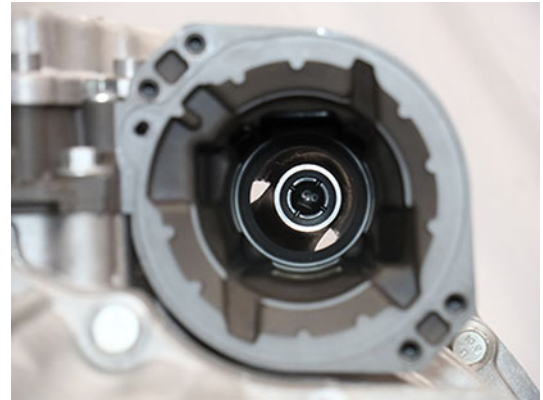

Reset and Install Linear Clutch Actuator (LCA)

1. Inspect LCA to determine next steps, reference images below:
 - If LCA is locked in the reset position, go to Install Linear Clutch Actuator (LCA).
 - If LCA is not locked in the reset position, go to Step 2.

Locked in Reset Position

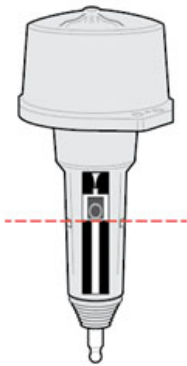

Not Locked in Reset Position

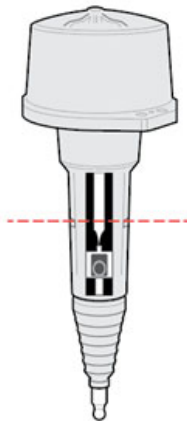

3. Inspect LCA to determine next steps, reference images below:
 - If LCA remains locked in the reset position, go to Step 4.
 - If LCA does not remain locked in the reset position, go to Step 2, repeat reset procedure.

Note: If LCA cannot be locked into the reset position, replace LCA.

CAUTION: Do not drop LCA. Dropping LCA may cause the LCA to unlock resulting in personal injury and/or component damage.

Locked in Reset Position

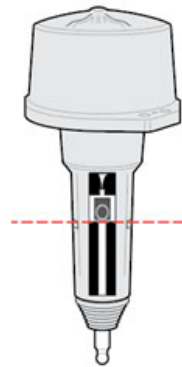

Not Locked in Reset Position

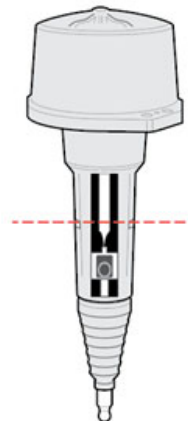

2. Place LCA push rod on a clean, flat surface. Tightly grasp LCA housing with both hands and push down on push rod to lock LCA into the reset position.



CAUTION: A large amount of force is required to lock the LCA into the reset position. Failure to tightly grasp the LCA housing with both hands while pushing down on push rod may cause unintended movement resulting in personal injury and/or component damage.



4. Clean all sealing surfaces on the MTM and LCA with a lint free cloth.

NOTICE: Do not use abrasive scrapers or powered tools to clean sealing surfaces or sealing surfaces may be damaged and leak.

5. Insert the LCA into the MTM.



6. Install 4 LCA T45 cap screws and torque to 23-28 Nm (17-21 lb-ft) in a criss-cross pattern.



Install the Release Bearing and Clutch Release Yoke

1. Install the upper Release Yoke socket over the rod end of the Linear Clutch Actuator (LCA) and press until attached.



2. Install the lower Release Yoke socket over the lower pivot on the clutch housing and press until attached.



3. Slide the Release Bearing over the input shaft and into the Release Yoke.



Install the Transmission

1. Refer to OEM guidelines for transmission installation.
2. Connect negative battery cable.

Fill Oil

Note: Perform the transmission fill procedure with transmission installed in vehicle to ensure proper transmission angle.

1. Remove the Oil Fill Plug with a 6 mm hex key.

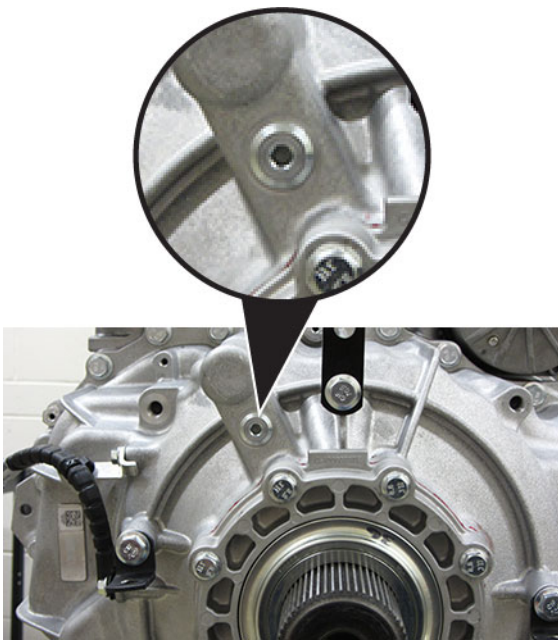

2. Place a suitable container under the Oil Check Plug and remove the Oil Check Plug with a 6 mm hex key.



3. Fill the transmission with PS-386 lube until a small amount of oil runs out of the Oil Check Plug hole.

Note: Fill capacity is approximately 7.5-8.5 liters (16-18 pints) depending on the transmission angle.

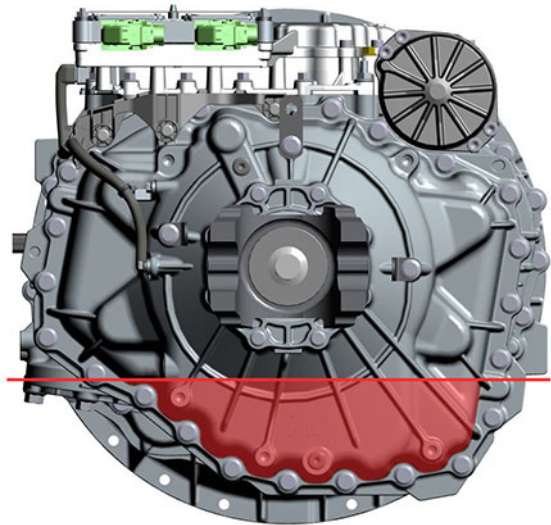
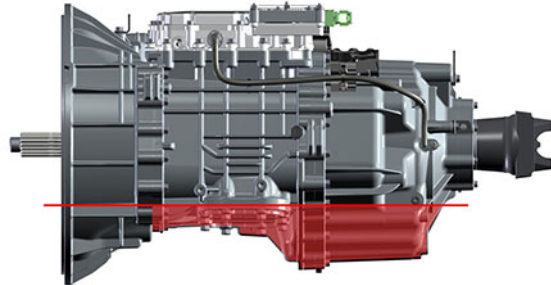

4. Inspect Oil Check Plug and O-ring for damage. If damaged, replace the Oil Check Plug; O-ring is serviced with plug.

5. Install the Oil Check Plug (6 mm) and torque to 24.5-29.5 Nm (18-22 lb-ft).

NOTICE: Do not over-torque the Oil Fill Plug or transmission damage may occur.



6. Inspect Oil Fill Plug and O-ring for damage. If damaged, replace the Oil Fill Plug; O-ring is serviced with plug.
7. Install the Oil Fill Plug (6 mm) and torque to 24.5-29.5 Nm (18-22 lb-ft).

NOTICE: Do not over-torque the Oil Fill Plug or transmission damage may occur.

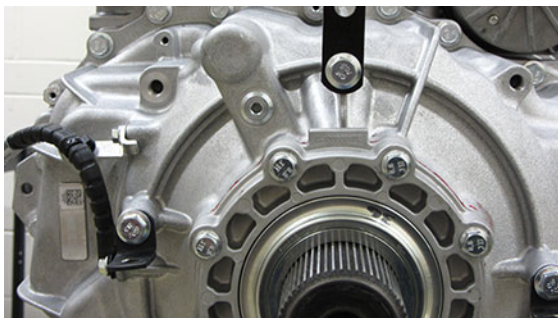

Clutch and Rail Calibration

To ensure proper operation, the TCM, clutch, MTM and transmission require a Clutch and Rail Calibration. Calibrations are automatically initiated when:

- LCA is in the reset position
- Transmission in "N" (Neutral)
- Key on engine running
- Vehicle air system pressure at operating range

NOTICE: Do not use service tool to initiate calibrations. Allow calibrations to automatically initiate.

Note: Vehicle display may indicate a flashing "CC" and "F" in gear display.

1. Set vehicle parking brake and chock wheels.
2. Ensure the driveline is connected between the transmission and axle.

Note: Clutch and Rail Calibrations cannot complete if the transmission output shaft is allowed to rotate.
3. Key on with engine running.
4. Allow vehicle air pressure to build to governor cut-off.

Note: Clutch and Rail Calibrations automatically initiate when vehicle air pressure reaches approximately 100 psi.
5. Ensure "N" (Neutral) is selected and engine is running. Wait approximately 2 minutes for calibrations to complete.

NOTICE: If process is interrupted, key off, wait 1 minute and go to Step 2.

 - If vehicle display indicates a solid "N: (Neutral) in gear display, calibrations are complete. Key off, go to Step 6.
 - If vehicle display continues to indicate a flashing "CC" and/or "F" in gear display or service transmission message, go to Step 5.
6. Key off and wait 1 minute.
7. Key on with engine off.
8. Connect ServiceRanger.

9. Go to “Fault Codes”.
 - If an Active transmission fault code is set, go to Endurant HD Troubleshooting Guide TRTS0950 **Diagnostic Procedure**.
 - If no Active transmission fault codes are set, select “Clear Eaton Faults” and follow on-screen prompts. Go to Step 9.
10. Disconnect ServiceRanger.
11. Key off.
12. Inspect transmission for a PTO.
 - If not PTO-equipped, process complete.
 - If PTO-equipped, start the engine and run for 1 to 2 minutes to fill the PTO with oil, key off and repeat the Fill Oil Procedure.



CAUTION: Failure to repeat the Fill Oil service procedure to verify proper transmission oil level when equipped with a PTO may result in low transmission oil and component damage.

Output Seal Assembly

Special Instructions

None

Special Tools

- Output Seal Driver (RR1001TR-8)
- Output Seal Driver Handle (RR1001TR-2)

Note: RR1001TR-2 is part of Output Seal Driver Kit (RR1001TR) and may have already been purchased to support prior transmission models.

- Plastic Scraper

Component Identification

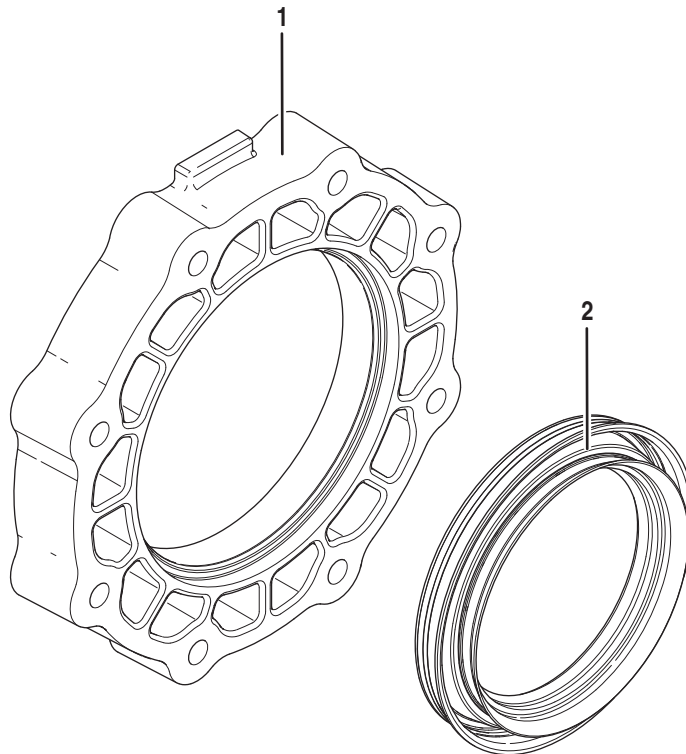

1. Rear Bearing Cover
2. Output Shaft Seal

Assemble the Output Seal

1. Place the Rear Bearing Cover on a flat clean surface the pry points down.

NOTICE: A new Rear Bearing Cover is required when replacing the Output Seal to ensure no leaks occur between the cover and new seal.



2. Place the Output Seal Driver (RR1001TR-8) onto the Output Seal Driver Handle (RR1001TR-2).
3. Place the Output Seal onto the Output Seal Driver (RR1001TR-8).



4. Install the Output Seal and driver assembly into the Rear Bearing Cover and drive until the seal is seated against the cover.

NOTICE: Fully seat Output Seal into Bearing Cover.



Lower Countershaft Cover and Inertia Brake

Special Instructions

None

Special Tools

None

Component Identification

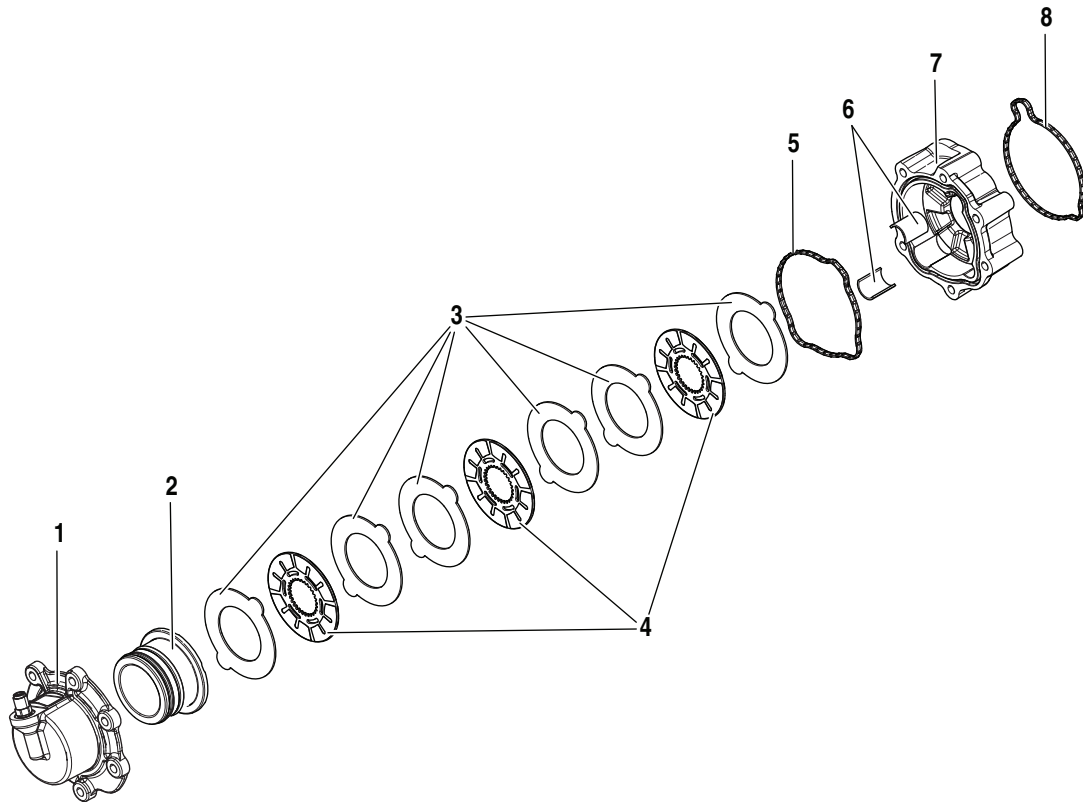

1. Inertia Brake Cover
2. Inertia Brake Piston
3. Steel Discs (x6)
4. Friction Discs (x3)
5. Seal - Front
6. Wear Guides (x2)
7. Inertia Brake Housing
8. Seal - Rear

Disassemble the Inertia Brake

1. Remove the clutch pack from the Inertia Brake Housing.



2. Remove the 2 wear guides from the Inertia Brake Housing.



3. Remove Seal from the front of the Inertia Brake Housing.



4. Remove Seal from the rear of the Inertia Brake Housing.



Assemble the Inertia Brake

1. Insert the Seal into the groove on the rear of the Inertia Brake Housing until fully seated.

Note: Reference “RRMT0027 - Clutch Housing Front Cover Kit” on page 586 for new Inertia Brake Housing part number, additional O-ring part number, and installation instructions.



2. Insert the Seal into the groove on the front of the Inertia Brake Housing until fully seated.



3. Install the 2 Wear Guides in the Inertia Brake Housing.



4. Install the inertia brake clutch pack in the order shown below:

- 1 Steel Disc,
- 1 Friction Disc,
- 2 Steel Discs,
- 1 Friction Disc,
- 2 Steel Discs,
- 1 Friction Disc, and
- 1 Steel Disc.

Note: Steel Discs align with Wear Guides. Friction Discs spline to the lower countershaft.

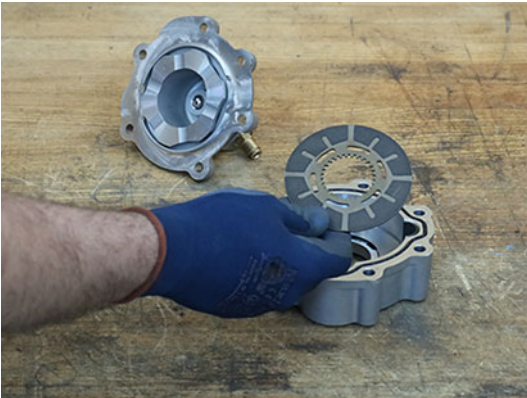

5. Place Inertia Brake Cover and Piston on the Housing. Align the bolt holes.

Input Shaft Pilot Bearing Wear Sleeve

Special Instructions

None

Special Tools

- Input Shaft Pilot Bearing Wear Sleeve Puller (RR1062TR)
- Wear Sleeve Installer (RR1061TR)
- Snap Ring Installer (RR1061TR-1)
- Wear Sleeve Driver (RR1061TR-2)

Component Identification

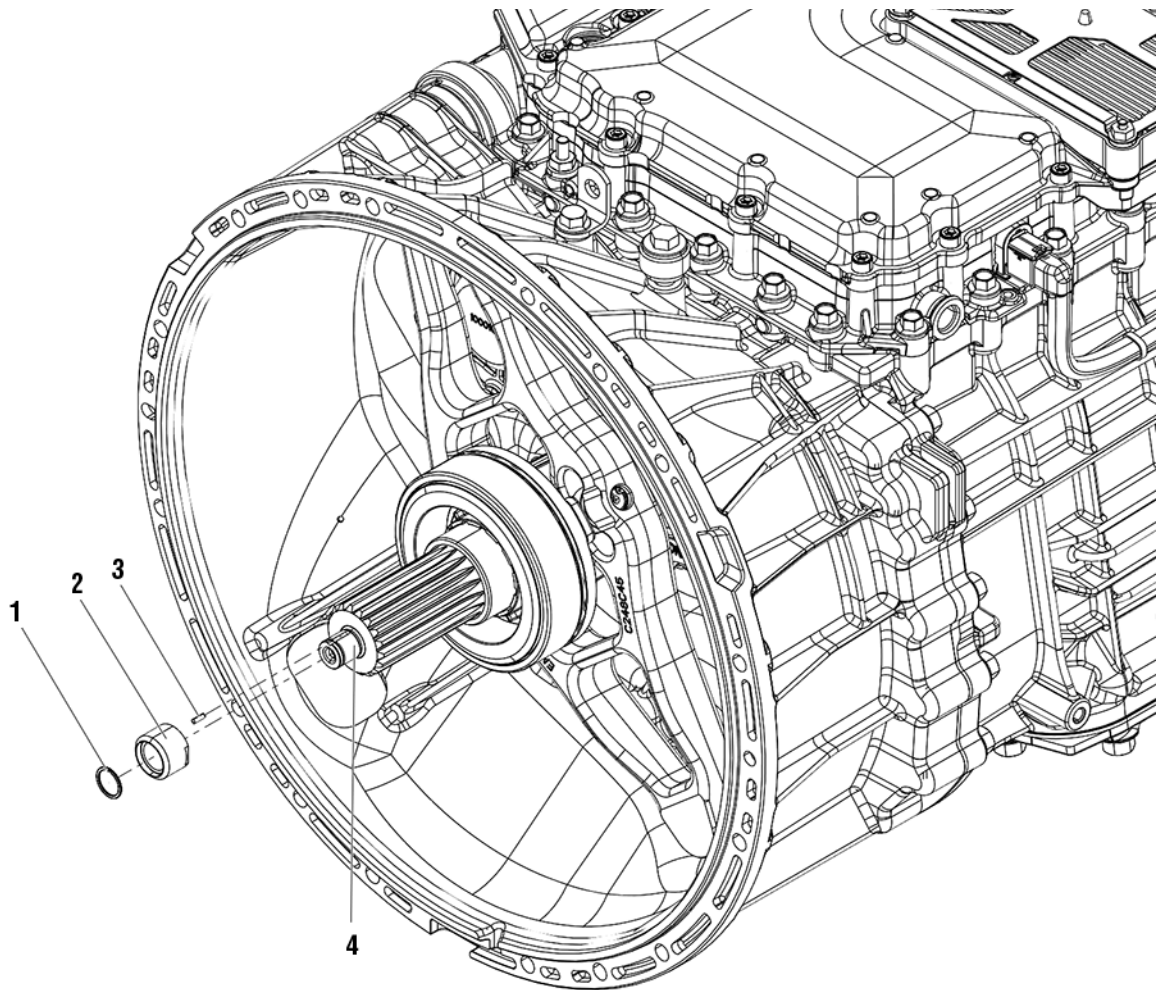

1. Spiral Snap Ring
2. Pilot Bearing Wear Sleeve
3. Wear Sleeve Alignment Pin
4. Input Shaft

Disassemble the Input Shaft Pilot Bearing Wear Sleeve

1. Remove the Spiral Snap Ring from the input shaft with a pick.



2. Install the Input Shaft Pilot Bearing Wear Sleeve Puller (RR1062TR) over the flats on the Pilot Bearing Wear Sleeve.



3. Tighten the 13 mm jackscrew on the Input Shaft Pilot Bearing Wear Sleeve Puller (RR1062TR) to remove Wear Sleeve.

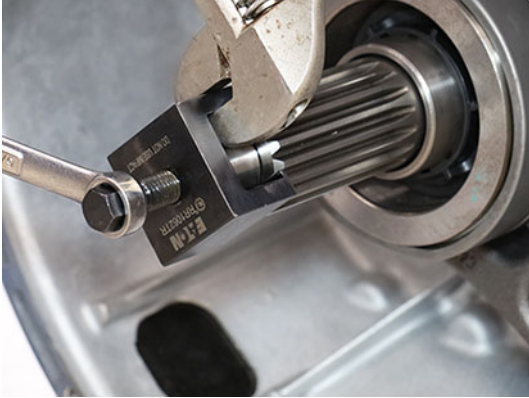

4. Remove the Wear Sleeve Alignment Pin.



Assemble the Input Shaft Pilot Bearing Wear Sleeve

1. Clean the Pilot Bearing Wear Sleeve surfaces on the input shaft.
2. Apply grease to alignment pin groove on the input shaft to hold the Wear Sleeve Alignment Pin in place.

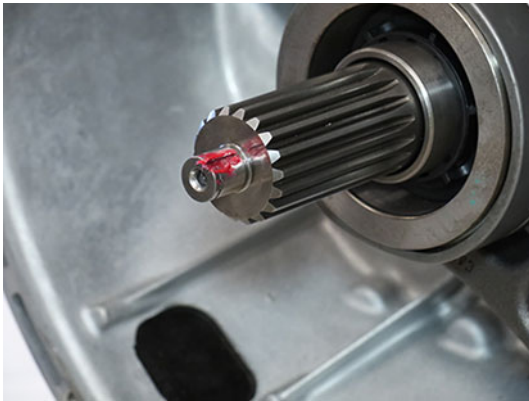

3. Slide the Wear Sleeve Alignment Pin into the groove on the input shaft.

NOTICE: Chamfered end of alignment pin must face forward.

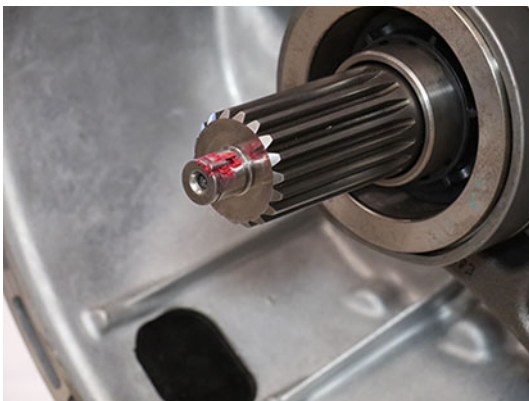

4. Align the groove in the Pilot Bearing Wear Sleeve with the Wear Sleeve Alignment Pin.



5. Hold the Pilot Bearing Wear Sleeve against the input shaft and lightly tap with a soft-faced hammer to start installation.



CAUTION: Keep fingers clear to avoid personal injury.

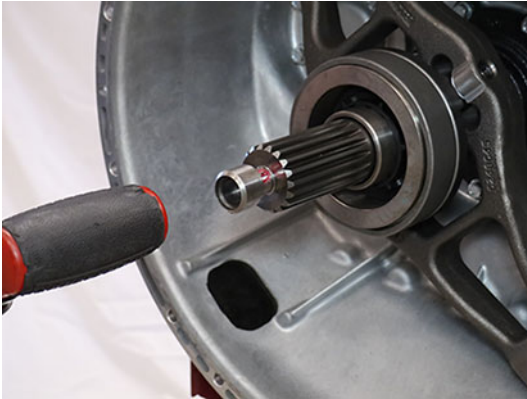

6. Use the Wear Sleeve Driver (RR1061TR-2) to fully seat the Pilot Bearing Wear Sleeve onto the input shaft.



7. Inspect the Pilot Bearing Wear Sleeve to ensure it is fully seated on the input shaft.

NOTICE: If there is a gap between the Pilot Bearing Wear Sleeve and the input shaft, the Wear Sleeve Alignment Pin may have moved out of the groove; remove the Pilot Bearing Wear Sleeve and re-perform assembly procedure.



8. Install a new Spiral Snap Ring onto the Snap Ring Installer (RR1061TR-1).



- Slide the Wear Sleeve Driver (RR1061TR-2) over the Snap Ring Installer (RR1061TR-1).



- While holding the Snap Ring Installer (RR1061TR-1) against the input shaft, slide the Wear Sleeve Driver (RR1061TR-2) forward and fully seat the Spiral Snap Ring into the snap ring groove.

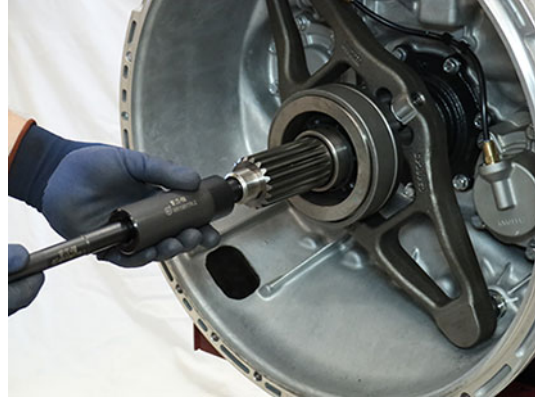

Input Shaft Cover

Special Instructions

None

Special Tools

- Output Shaft Installer/Input Shaft Seal Driver (RR1070TR)

Component Identification

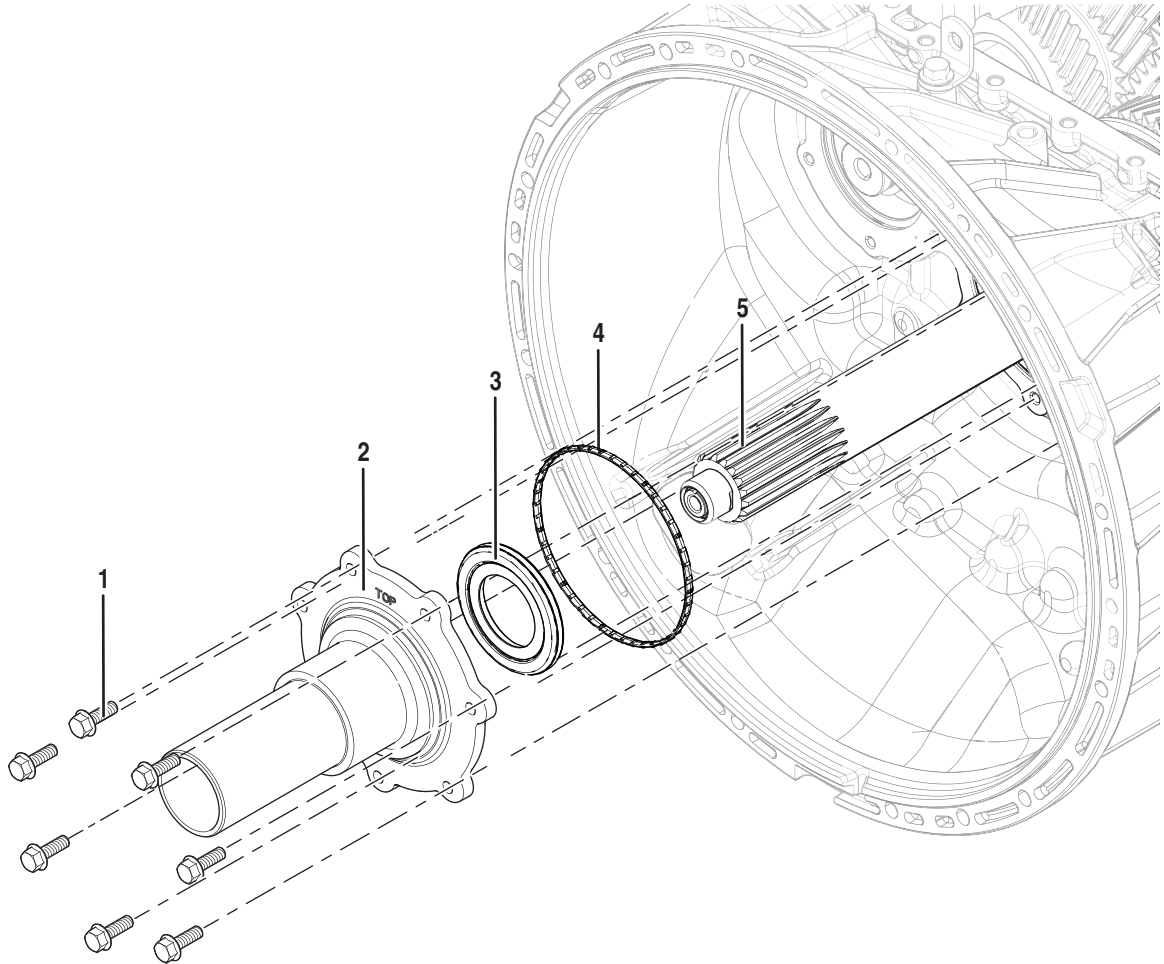

1. Input Shaft Cover Cap Screws (x7) - 13 mm
2. Input Shaft Cover
3. Input Shaft Seal
4. Input Shaft Cover Seal
5. Input Shaft

Disassemble the Input Shaft Cover

1. Remove the Input Shaft Cover Seal.



2. Place the Input Shaft Cover into a vice equipped with soft-faced jaw pads with the drain back port at the 8 o'clock position.

Note: Do not over-tighten the vice jaws.



3. Place a lint free cloth over the Input Shaft Cover.



4. Using two pry bars, lift under the Input Shaft Seal at the 12 o'clock position and remove the Input Shaft Seal from the Input Shaft Cover.



5. Clean and inspect the Input Shaft Seal bore. If seal bore is damaged, replace the Input Shaft Cover.



Assemble the Input Shaft Cover

1. Place the Input Shaft Cover on a bench and place the Input Shaft Seal over the seal bore.



2. Place Output Shaft Installer/Input Shaft Seal Driver (RR1070TR) onto the Input Shaft Seal and drive until seal is seated into the cover.

Note: Fully seat Seal into Input Shaft Cover



3. Install Input Shaft Cover Seal.



Main Shaft

Special Instructions

Ensure to determine and install the Ideal Main Shaft Selective Washer during Main Shaft Assembly.

Note: The Main Shaft End-Play Service Procedure is required if one or more of the following parts are replaced:

- Clutch Housing
- Main Housing
- Input Shaft
- Input Shaft Bearing
- Main Shaft Bearing



CAUTION: Failure to determine and install the Ideal Main Shaft Selective Washer results in incorrect Main Shaft End-Play resulting in transmission component damage.

Special Tools

- 5/32 OD Air Line

Component Identification

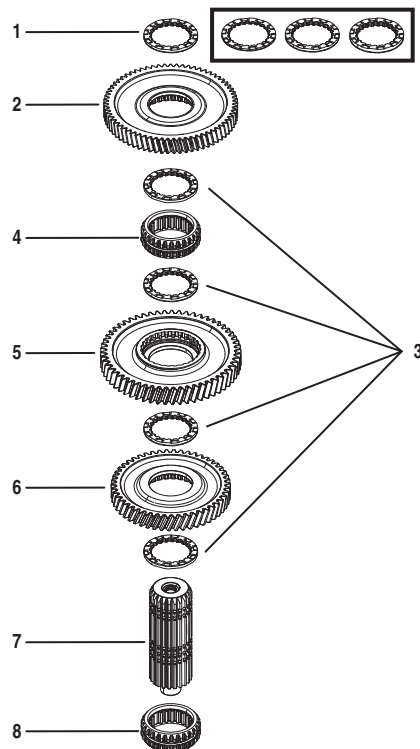

1. Main Shaft Selective Washer - 6.525 mm (0.257 in), 6.712 mm (0.264 in) or 6.900 mm (0.272 in) (x1)

2. Reverse Gear

3. Main Shaft Washer 6.525 mm (0.257 in) (x4)

4. Rail D Sliding Clutch

5. Primary Driven Gear

6. Secondary Driven Gear

7 Main Shaft Assembly

8. Rail C Sliding Clutch

Disassemble the Main Shaft

1. Place Main Shaft Assembly horizontally on a clean flat surface.



CAUTION: Secure Main Shaft Assembly while on flat surface to avoid unexpected movement. Failure to properly secure Main Shaft Assembly could result in component damage and/or personal injury.

2. Remove Rail C Sliding Clutch.

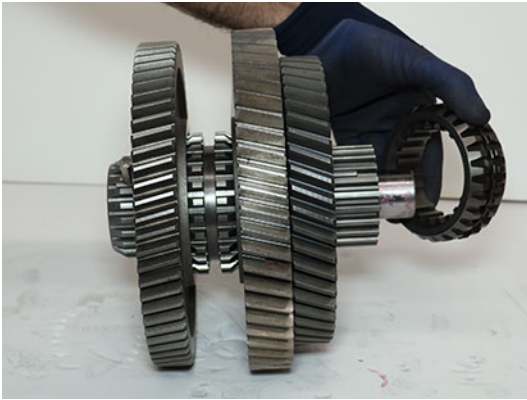

3. Place Main Shaft assembly vertically on a clean flat surface.



CAUTION: Secure Main Shaft Assembly while on flat surface to avoid unexpected movement. Failure to properly secure Main Shaft Assembly could result in component damage and/or personal injury.



4. Remove Main Shaft Key.



5. Rotate and remove the Main Shaft Selective Washer above Reverse Gear.



6. Measure the Main Shaft Selective Washer with a micrometer and record reading in table.

Note: The Main Shaft Selective Washer above Reverse Gear is available in 3 thicknesses, 6.525 mm (0.257 in), 6.712 mm (0.264 in) or 6.900 mm (0.272 in), to control Main Shaft End-Play. The recorded Main Shaft Selective Washer thickness is required for the Main Shaft Assembly Service Procedure. The 4 other Main Shaft Washers are 6.525 mm (0.257 in).

Note: Need image of using micrometer to measure high points on selective washer

| Main Shaft Selective Washer Thickness |
|---|
| |

7. Remove Reverse Gear.



8. Rotate and remove standard Main Shaft Washer above Rail D Sliding Clutch.



9. Remove Rail D Sliding Clutch.



- 10.** Using magnets, rotate and remove standard Main Shaft Washer above Primary Driven Gear.

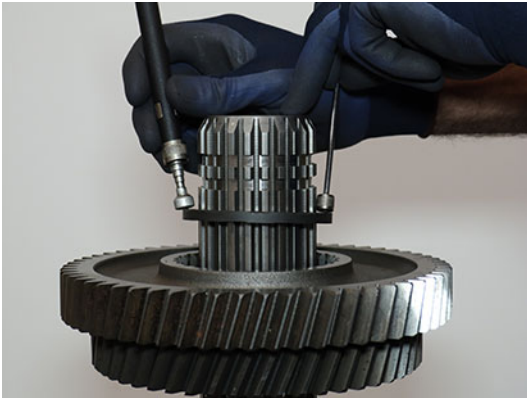

- 12.** Rotate and remove Main Shaft Washer above Secondary Driven Gear.



- 13.** Remove Secondary Driven Gear.



- 11.** Remove Primary Driven Gear.



- 14.** Rotate and remove last Main Shaft Washer.



Assemble the Main Shaft

1. Place Main Shaft vertically on a clean flat surface.



CAUTION: Secure Main Shaft Assembly while on flat surface to avoid unexpected movement. Failure to properly secure Main Shaft Assembly could result in component damage and/or personal injury.



2. Install and rotate Main Shaft Washer, 6.525 mm (0.257 in), onto Main Shaft.



3. Install a 5/32 OD air line into the main shaft spline to align and hold washer in place.



4. Install Secondary Driven Gear on Main Shaft with clutching teeth facing down.



6. Slide the 5/32 OD air line up to align and hold washer in place.



5. Install and rotate Main Shaft Washer, 6.525 mm (0.257 in), above Secondary Driven Gear.



7. Install Primary Driven Gear on Main Shaft with clutching teeth facing up.

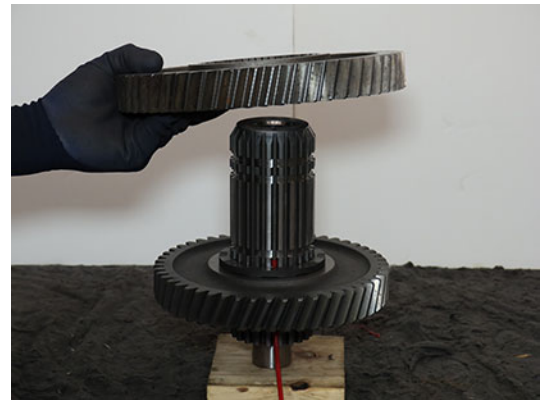

8. Using magnets, install and rotate Main Shaft Washer, 6.525 mm (0.257 in) above Primary Driven Gear.

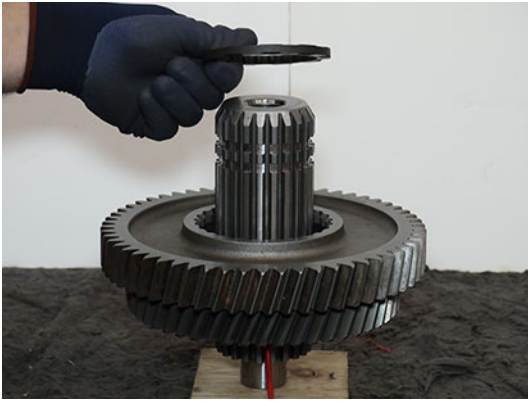

9. Slide the 5/32 OD air line up to align and hold washer in place.

10. Install Rail D Sliding Clutch and align the double slot with the 5/32 OD air line.

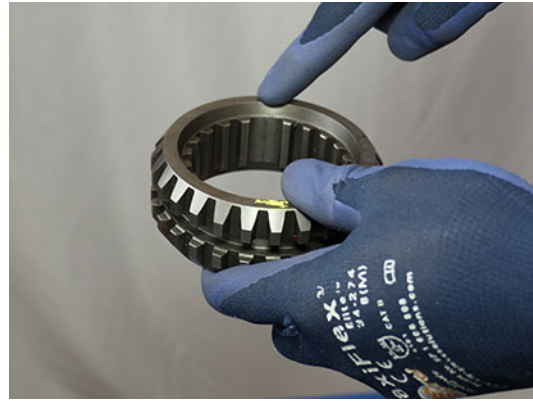

11. Install and rotate Main Shaft Washer, 6.525 mm (0.257 in), above Rail D Sliding Clutch.



12. Slide the 5/32 OD air line up to align and hold washer in place.



13. Install Reverse Gear with clutching teeth facing down.



14. Determine the Ideal Main Shaft Selective Washer to install above Reverse Gear:



CAUTION: Failure to determine and install the Ideal Main Shaft Selective Washer results in incorrect Main Shaft End-Play resulting in transmission component damage.

- If one or more of the following parts were replaced: Clutch Housing, Main Housing, Input Shaft, Input Shaft Bearing or Main Shaft Bearing, install the 6.525 mm (0.257 in) Main Shaft Selective Washer.

Note: The Main Shaft End-Play Service Procedure is required.

- If NONE of the following parts were replaced: Clutch Housing, Main Housing, Input Shaft, Input Shaft Bearing, or Main Shaft Bearing, install the Main Shaft Selective Washer recorded in Step 6 of the Main Shaft Disassembly Service Procedure: 6.525 mm (0.257 in), 6.712 mm (0.264 in) or 6.900 mm (0.272 in).

Note: The Main Shaft End-play Service Procedure is NOT required.



15. Slide the 5/32 OD air line up to align and hold washer in place.



16. Install Main Shaft Key at the same spline as the 5/32 OD air line.

Note: Insert Main Shaft Key while removing air line.



17. Install a magnet on Main Shaft Key to hold the key in place during final Main Shaft Assembly and installation into transmission.

Note: Remove magnet from Main Shaft Key after installation of Main Shaft Assembly onto transmission.



18. Place Main Shaft Assembly horizontally on a clean flat surface.



CAUTION: Secure Main Shaft Assembly while on flat surface to avoid unexpected movement. Failure to properly secure Main Shaft Assembly could result in component damage and/or personal injury.

19. Install Rail C Sliding Clutch and align the double slot with Main Shaft Key.

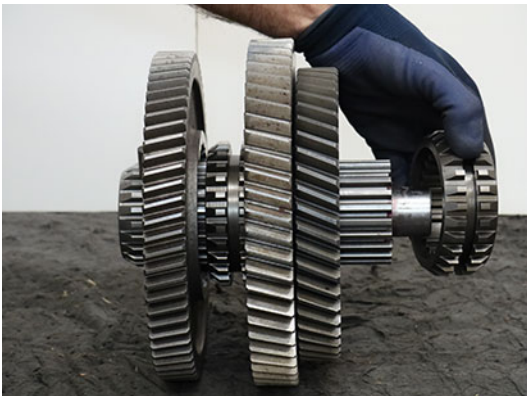
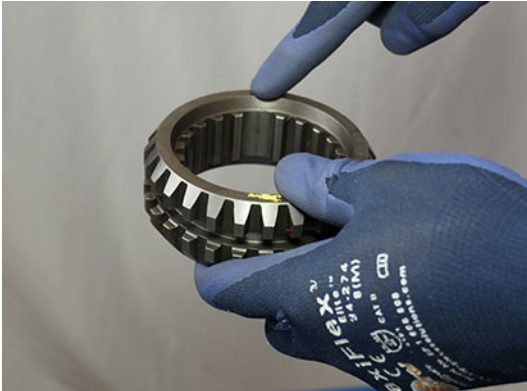

Input Shaft

Special Instructions

- Input Shaft replacement requires transmission to be disassembled. Perform Main Shaft and Counter-shaft Service Procedure to access Input Shaft.
- Clutch Housing is approximately 558 mm (22 inches) wide. Only perform steps to Disassemble/Assemble the Input Shaft when using a press. If the Clutch Housing is too large for the available press, perform steps to Manually Disassemble/Assemble Input Shaft with Input Shaft Press (RR1085TR).



CAUTION: A press is required for the removal and installation of the Input Shaft. Failure to use a press to remove and install the Input Shaft may result in transmission component damage.

Component Identification

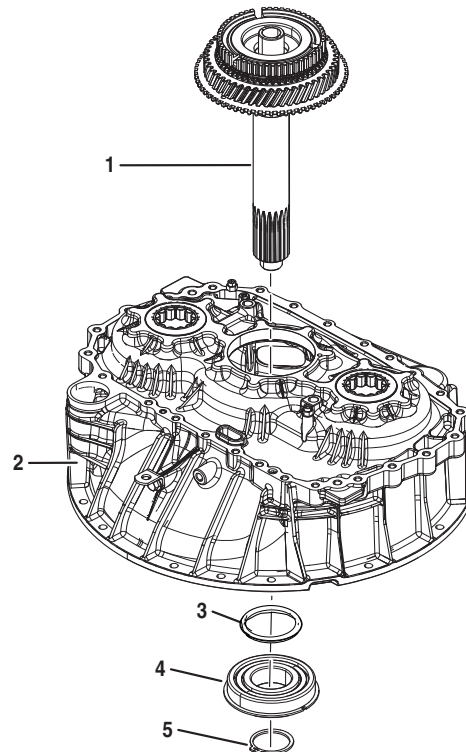

1. Input Shaft Assembly
2. Clutch Housing
3. Input Shaft Bearing O-ring
4. Input Shaft Bearing
5. Input Shaft Snap Ring

Special Tools

- Input Shaft Cup (RR1085TR-6)
- Input Shaft Stand (RR1073TR)
- Input Shaft Bearing Removal and Installation Tool (RR1075TR)
- Universal Driver Handle (OE8044-T0)

Note: If manually pressing the Input Shaft, additional tools are needed.

- Input Shaft Press (RR1085TR)
- Front Bearing Capture Plate (RR1085TR-7)
- Input Bearing Driver (RR1049TR)
- 4 (2 inch 7/16 inch Grade 8 or 50.8 mm M12 Grade 10.9) cap screws, washers and nuts

Disassemble the Input Shaft

1. Ensure Input Shaft Snap Ring is removed.
2. Place Clutch Housing in press with Input Shaft up.



CAUTION: Clutch Housing weighs approximately 50 lbs. Keep fingers clear of pinch points between Clutch Housing and other surfaces. Dropping Clutch Housing could result in component damage and/or personal injury.

NOTICE: A press is required for the removal and installation of the Input Shaft. Failure to use a press results in Input Shaft and/or Clutch Housing damage.

NOTICE: Support the Clutch Housing to avoid damaging the housing and sealing surface.

Note: Clutch Housing is approximately 558 mm (22 inches) wide. If the Clutch Housing is too large for the available press, perform steps to Manually Disassemble Input Shaft with Input Shaft Press (RR1085TR).



3. Place Input Shaft Cup (RR1085TR-6 on the end of the Input Shaft.



4. Press Input Shaft from Clutch Housing.



5. Place Clutch Housing in press with flywheel housing side of the Clutch Housing down.

NOTICE: Support the Clutch Housing to avoid damaging the housing.

6. Place Input Shaft Bearing Removal and Installation Tool (RR1075TR) and Universal Driver Handle (OE8044-T0) onto Input Shaft Bearing.

7. Press Input Shaft Bearing from Clutch Housing.

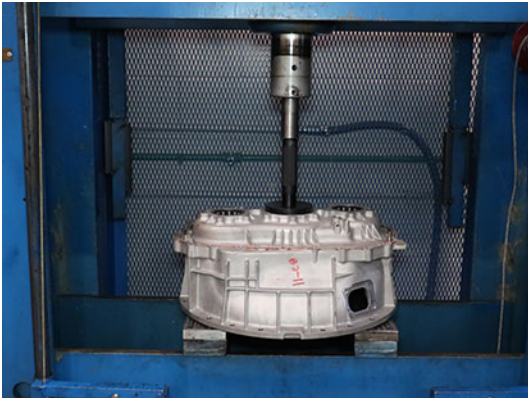

8. If present, remove Input Shaft Bearing O-ring and discard.

Note: Install a new Input Shaft Bearing O-ring when assembling Clutch Housing with chamfered bearing bores.



Assemble the Input Shaft

1. Place Clutch Housing in press with flywheel housing side up.

NOTICE: Support the Clutch Housing to avoid damaging the housing and sealing surface.

2. Inspect Input Shaft bearing bore for chamfered edge.
 - If chamfer is present, go to Step 3.
 - If chamfer is NOT present, go to Step 4.

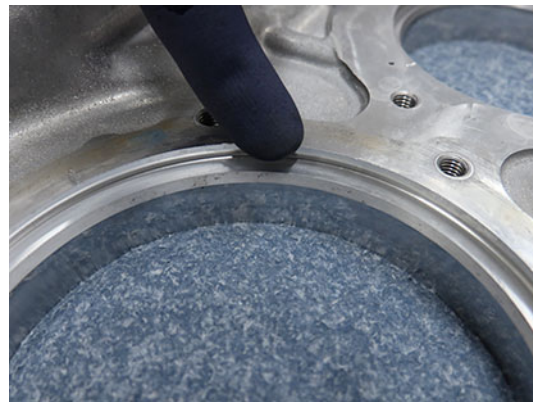

- Slide Input Shaft Bearing O-ring on Input Shaft Bearing until fully seated against snap ring.

Note: Install a new Input Shaft Bearing O-ring when assembling Clutch Housing with chamfered bearing bores.

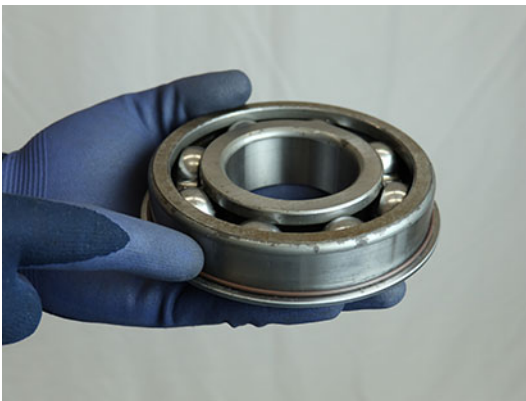

- Place Input Shaft Bearing Removal and Installation Tool (RR1075TR) and Universal Driver Handle (OE8044-T0) onto Input Shaft Bearing.

- Press Input Shaft Bearing into Clutch Housing.

NOTICE: Do not over press bearing into Clutch Housing. Over pressing could result in component damage.

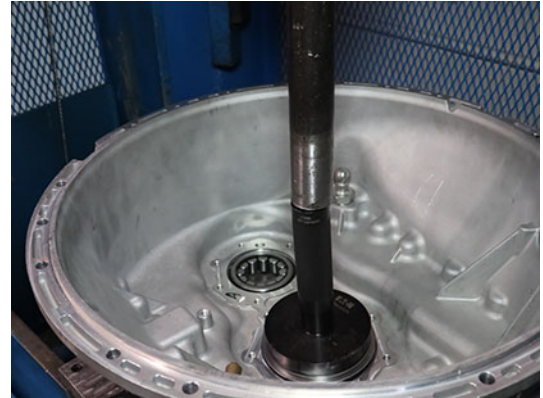

- Verify Input Shaft Bearing is fully seated in Clutch Housing.



7. Place Clutch Housing in press with flywheel housing side of the Clutch Housing down on Input Shaft Stand (RR1073TR), supporting the Inner Bearing Race of the Input Shaft Bearing.

NOTICE: Support the Inner Bearing Race to avoid damaging the Input Shaft Bearing in the Clutch Housing.

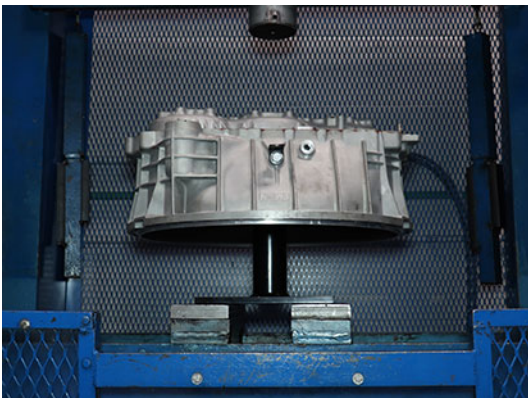
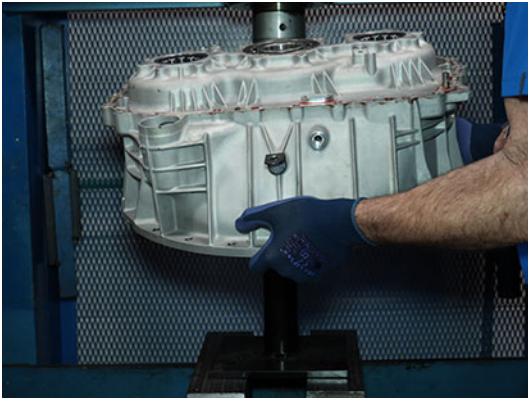

8. Install Input Shaft into Clutch Housing.



9. Place Input Shaft Cup (RR1085TR-6) on the Input Shaft.



10. Press Input Shaft into Input Shaft Bearing until fully seated.

NOTICE: Do not over press Input Shaft into Clutch Housing. Over pressing could result in component damage.



11. Install Input Shaft Snap Ring.

NOTICE: A new snap ring is required when reinstalling. A used snap ring may detach from Input Shaft and result in transmission component damage.

Note: The snap ring will not install if Input Shaft is not fully seated into Input Shaft Bearing.



Install Input Shaft Cover

1. Clean sealing surfaces on the Clutch Housing and Input Shaft Cover.
2. Slide the Input Shaft Cover over the Input Shaft.

Note: Align "TOP" at 12 o'clock.



3. Install the 7 Input Shaft Cover 13 mm cap screws and torque to 21-25 Nm (16-19 lb-ft) in a criss-cross pattern.



Manually Disassemble Input Shaft with Input Shaft Press (RR1085TR)

1. Ensure Input Shaft Snap Ring is removed.
2. Place and support Clutch Housing on a bench.

Note: Allow space to press the Input Shaft out of Clutch Housing.

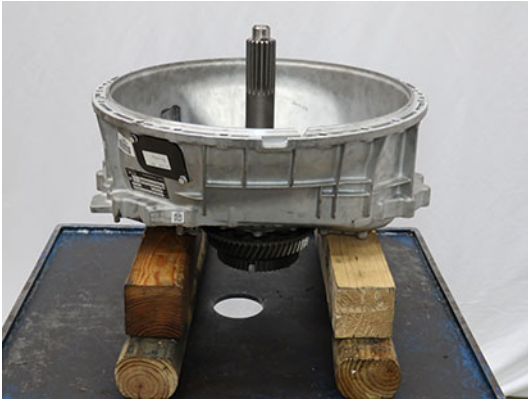

3. Place Input Shaft Cup (RR1085TR-6) on the end of the Input Shaft.



4. Place Input Shaft Press (RR1085TR) on the flywheel housing side of the Clutch Housing.



CAUTION: Input Shaft Press weighs approximately 30 lbs. Keep fingers clear of pinch point between Input Shaft Press and other surfaces. Dropping Input Shaft Press could result in component damage and/or personal injury.

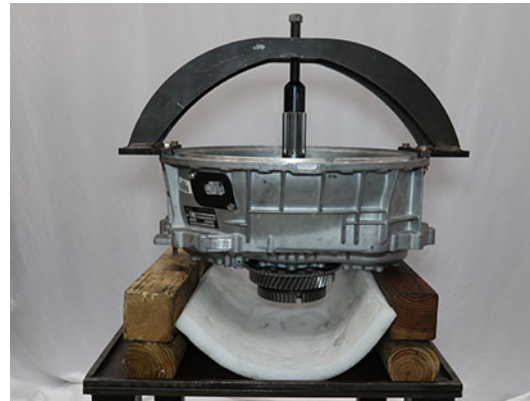

5. Install and hand tighten 4 (2 inch 7/16 inch Grade 8 or 50.8 mm M12 Grade 10.9) cap screws, washers and nuts to attach press to housing.



6. Place soft material under Input Shaft.



7. Rotate jack screw to press Input Shaft out of Clutch Housing.
8. Remove 4 cap screws, washers, nuts and Input Shaft Press (RR1085TR) from Clutch Housing.

CAUTION: Input Shaft Press weighs approximately 30 lbs. Keep fingers clear of pinch points between Input Shaft Press and other surfaces. Dropping Input Shaft Press could result in component damage and/or personal injury.

9. Place and support Clutch Housing on a bench.

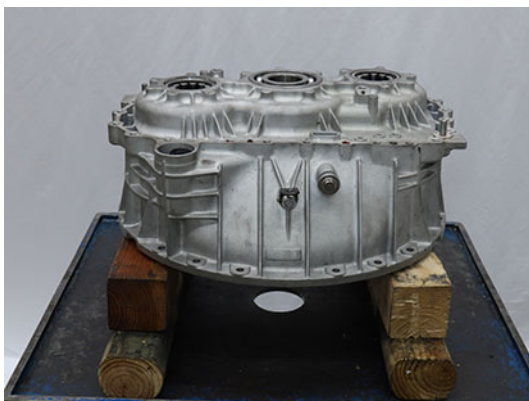

10. Install Input Shaft Press (RR1085TR) on the Main Housing side of the Clutch Housing aligning the 3 notches on the side of Linear Clutch Actuator opening.



CAUTION: Input Shaft Press weighs approximately 30 lbs. Keep fingers clear of pinch points between Input Shaft Press and other surfaces. Dropping Input Shaft Press could result in component damage and/or personal injury.

NOTICE: Protect Clutch Housing to Main Housing seal- ing surface from damage or an oil leak may occur.

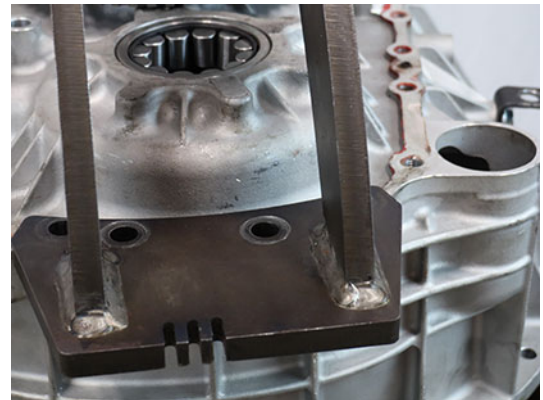

11. Install and hand tighten 4 Main Housing to Clutch Housing 16 mm cap screws in the inboard holes on each side of the press.

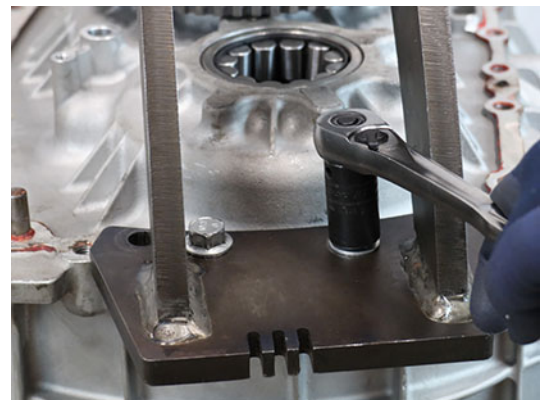

12. Place Input Shaft Bearing Removal and Installation Tool (RR1075TR) and Input Shaft Cup (RR1085TR-6) onto Input Shaft Bearing.



13. Rotate jack screw to press Input Shaft Bearing out of Clutch Housing.



14. If present, remove Input Shaft Bearing O-ring and discard.

Note: Install a new Input Shaft Bearing O-ring when assembling Clutch Housing with chamfered bearing bores.



15. Remove 4 cap screws, washers, nuts and Input Shaft Press (RR1085TR) from Clutch Housing.



CAUTION: Input Shaft Press weighs approximately 30 lbs. Keep fingers clear of pinch points between Input Shaft Press and other surfaces. Dropping Input Shaft Press could result in component damage and/or personal injury.

Manually Assemble Input Shaft with Input Shaft Press (RR1085TR)

1. Inspect Input Shaft bearing bore for chamfered edge.
 - If chamfer is present, go to Step 2.
 - If chamfer is NOT present, go to Step 3.



2. Slide Input Shaft Bearing O-ring on Input Shaft Bearing until fully seated against snap ring.

Note: Install a new Input Shaft Bearing O-ring when assembling Clutch Housing with chamfered bearing bores.

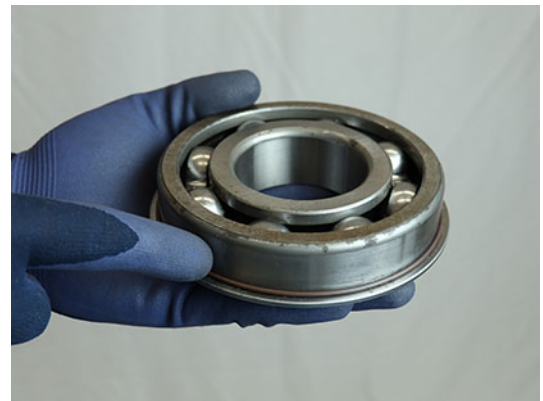

3. Place Input Shaft Press (RR1085TR) on the flywheel housing side of the Clutch Housing.



CAUTION: Input Shaft Press weighs approximately 30 lbs. Keep fingers clear of pinch point between Input Shaft Press and other surfaces. Dropping Input Shaft Press could result in component damage and/or personal injury.

4. Install and hand tighten 4 (2 inch 7/16 inch Grade 8 or 50.8 mm M12 Grade 10.9) cap screws, washers and nuts to attach press to housing.



5. Place Input Shaft Bearing into Clutch Housing.
6. Place Input Shaft Bearing Removal and Installation Tool (RR1075TR), Input Bearing Driver (RR1049TR) and Input Shaft Cup (RR1085TR-6) onto Input Shaft Bearing.

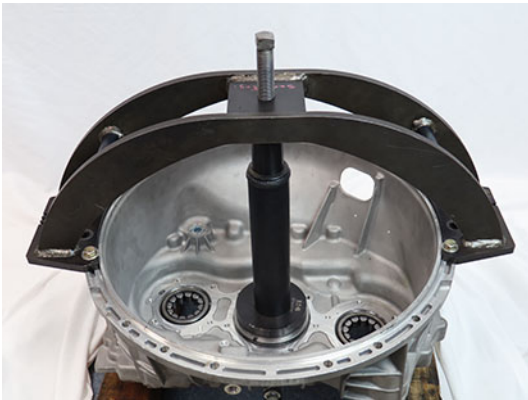

7. Rotate jack screw to press Input Shaft Bearing into Clutch Housing.

NOTICE: Do not over press bearing into Clutch Housing. Over pressing could result in component damage.

8. Remove Input Shaft Bearing Removal and Installation Tool (RR1075TR), Input Bearing Driver (RR1049TR) and Input Shaft Cup (RR1085TR-6).

9. Verify Input Shaft Bearing is fully seated in Clutch Housing.



10. Install Front Bearing Capture Plate (RR1085TR-7) to the Clutch Housing using the Input Shaft Cover threaded mounting holes and hand tighten 4 plate cap screws with a 6 mm hex key.

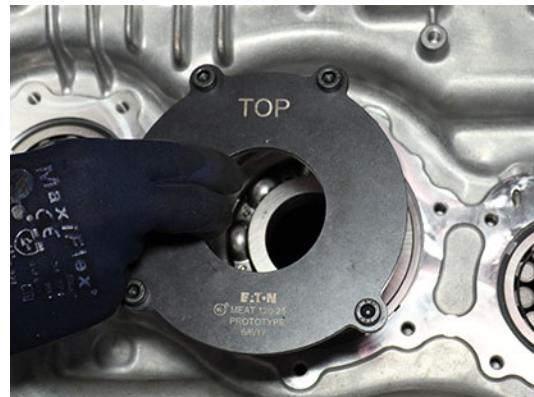

11. Torque cap screws to 21-25 Nm (16-19 lb-ft) in a criss-cross pattern.

12. Place and support Clutch Housing on a bench.

Note: Allow space to press the Input Shaft into Clutch Housing.

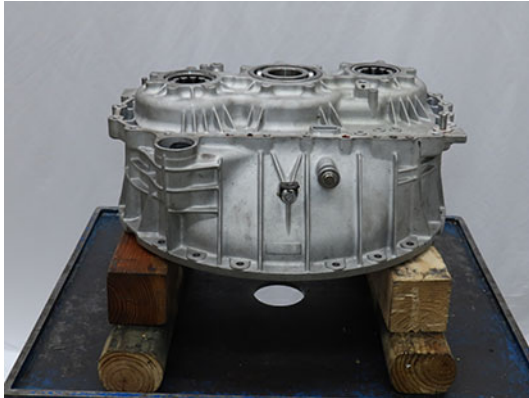

13. Install Input Shaft into Clutch Housing.



14. Place Input Shaft Cup (RR1085TR-6) onto Input Shaft.



15. Install Input Shaft Press (RR1085TR) on the Main Housing side of the Clutch Housing aligning the 3 notches on the side of Linear Clutch Actuator opening.



CAUTION: Input Shaft Press weighs approximately 30 lbs. Keep fingers clear of pinch points between Input Shaft Press and other surfaces. Dropping Input Shaft Press could result in component damage and/or personal injury.

NOTICE: Protect Clutch Housing to Main Housing seal surface from damage or an oil leak may occur.

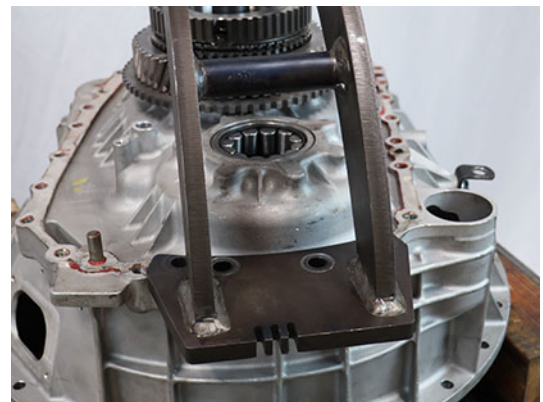

16. Install and hand tighten 4 Main Housing to Clutch Housing 16 mm cap screws in the inboard holes on each side of the press.

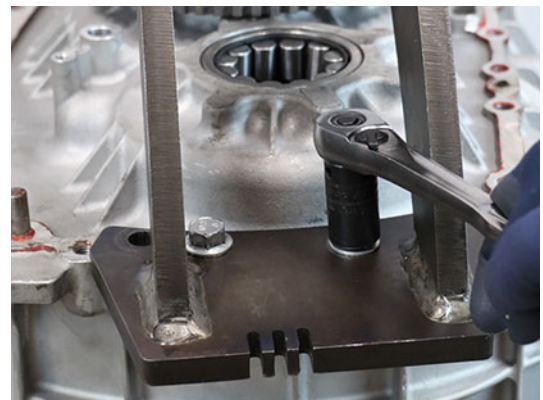

17. Rotate jack screw to press Input Shaft into Clutch Housing until fully seated.

NOTICE: Do not over press Input Shaft into Clutch Housing. Over pressing could result in component damage.



18. Remove 4 cap screws, washers, nuts and Input Shaft Press (RR1085TR) from Clutch Housing.



CAUTION: Input Shaft Press weighs approximately 30 lbs. Keep fingers clear of pinch points between Input Shaft Press and other surfaces. Dropping Input Shaft Press could result in component damage and/or personal injury.

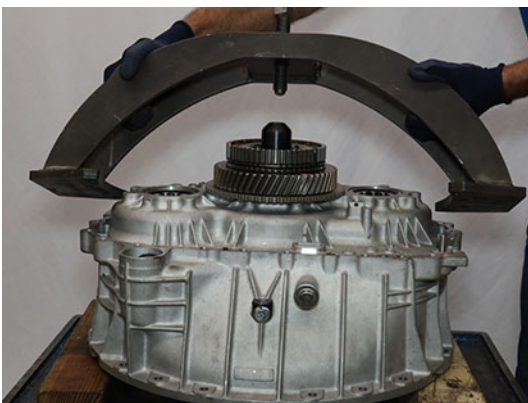

19. Remove Front Bearing Capture Plate (RR1085TR-7) from Clutch Housing.



20. Install Input Shaft Snap Ring.

NOTICE: A new snap ring is required when reinstalling. A used snap ring may detach from Input Shaft and result in transmission component damage.

Note: The snap ring will not install if Input Shaft is not fully seated into Input Shaft Bearing.



21. Go to and perform the “Main Shaft End-Play Service Procedure” on page 480 to continue.

Main Housing

Special Instructions

For Bearing Lock installation: Print the Bearing Lock Templates from the Appendix section. Cut out the two templates for both Main Case Countershaft Bearings. Both templates will be used to mark bearing openings to properly place bearings in Main Case.

Special Tools

- Countershaft Bearing Installer (RR1076TR)
- Main Shaft Bearing Installer (RR1077TR)
- Input Shaft Bearing Removal and Installation Tool (RR1075TR)
- Universal Driver Handle (OE8044-T0)

Note: Reference the appendix for Main Housing Bearing Templates on page 466.

Component Identification

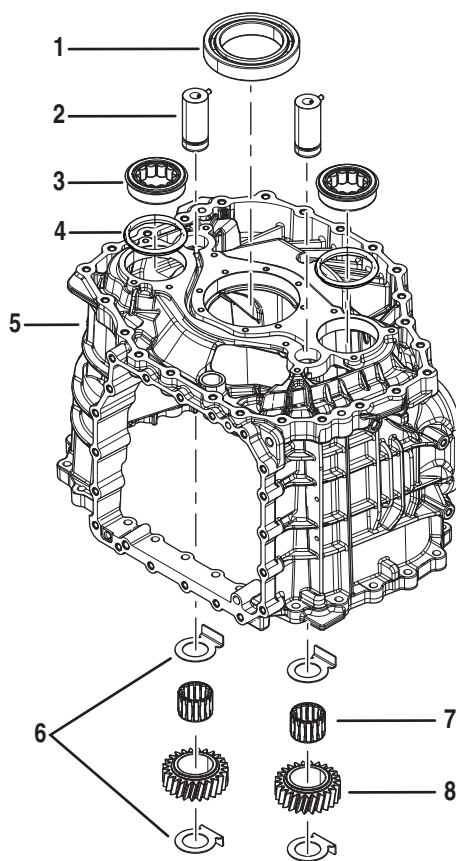

1. Main Shaft Bearing
2. Reverse Idler Gear Shaft (x2)
3. Rear Countershaft Bearings (x2)
4. Countershaft Bearing O-rings (x2) (Only use with Chamfered Bearing Bores)

5. Main Housing
6. Reverse Idler Gear Thrust Washers (x2)
7. Reverse Idler Gear Needle Bearings (x2)
8. Reverse Idler Gear (x2)

Remove the Fluid Pressure Sensor (FPS)

1. Unlatch and disconnect the OEM 3-Way Transmission Fluid Pressure Sensor (FPS) Connector.

Note: There are two possible Main Housing FPS port designs. FPS removal and installation have the same procedure for both designs.

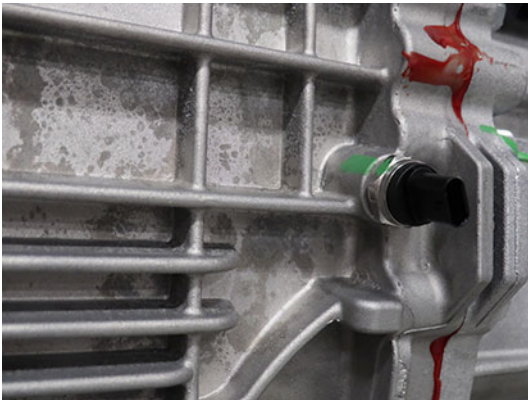
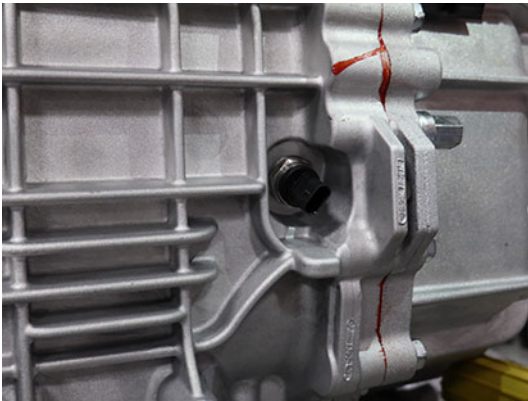

2. Remove the Transmission FPS (24 mm) threaded into the main housing.



Disassemble the Main Housing

1. Place Main Housing vertically on a bench with the Main and Clutch Housing mating surface down.



CAUTION: Main Housing weighs approximately 50 lbs. Keep fingers clear of pinch point between Main Housing and other surfaces. Dropping Main Housing could result in component damage and/or personal injury.

2. Remove Lower Reverse Idler Gear Shaft from Main Housing by pushing shaft up.



3. Remove Lower Reverse Idler Gear, washers and bearing from Main Housing.

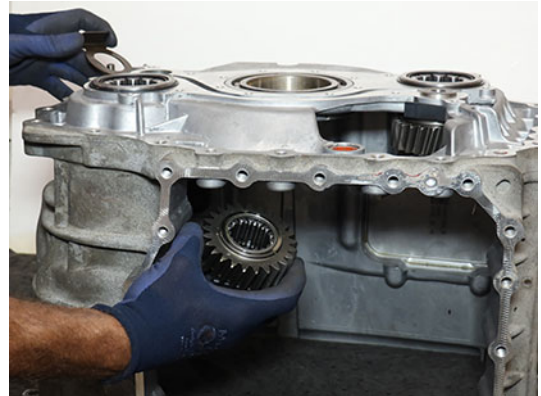

4. Remove Upper Reverse Idler Gear Shaft from Main Housing by pushing shaft up.



5. Remove Upper Reverse Idler Gear, washers and bearing from Main Housing.

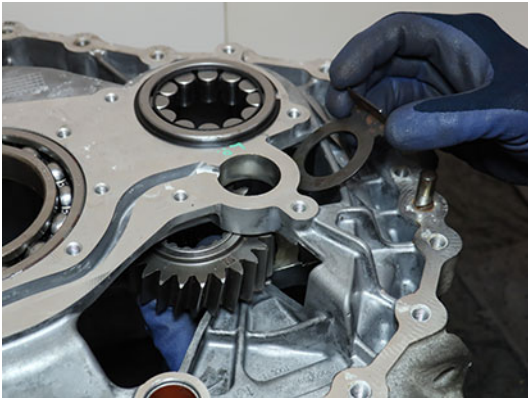

6. Place Main Housing in press and support housing on the Oil Pump Assembly surface.



CAUTION: Main Housing weighs approximately 50 lbs. Keep fingers clear of pinch point between Main Housing and other surfaces. Dropping Main Housing could result in component damage and/or personal injury.

NOTICE: Support the Main Housing to avoid damaging the housing and sealing surface.

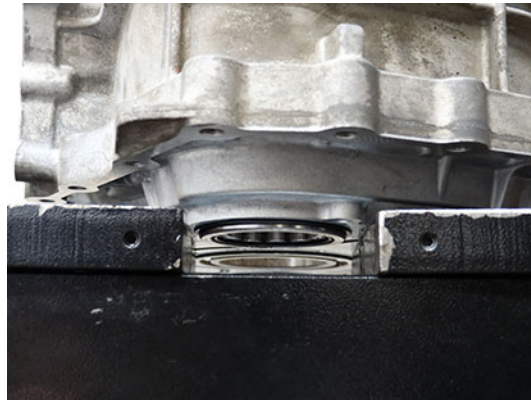

7. Place Countershaft Bearing Installer (RR1076TR) and Universal Driver Handle (OE8044-T0) onto Rear Upper Countershaft Bearing.
8. Press Rear Upper Countershaft Bearing out of Main Housing.

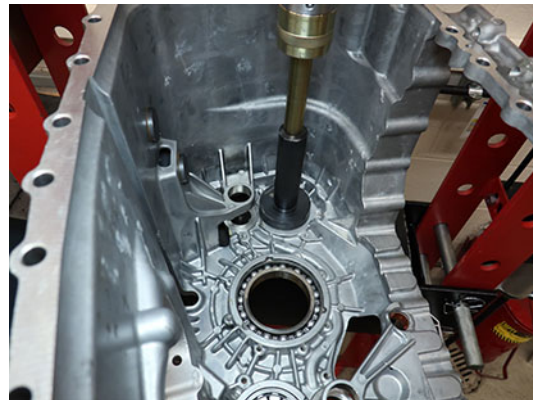

9. If present, remove Countershaft Bearing O-ring and discard.

Note: Install new Countershaft Bearing O-rings when assembling Main Housing with chamfered bearing bores.



10. Place Main Housing vertically in press and support housing on the Oil Pump Assembly surface.

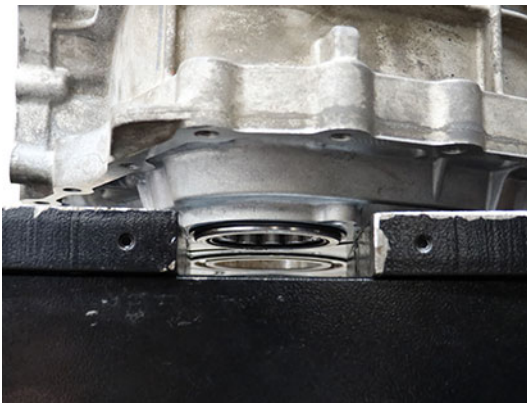

11. Place Input Shaft Bearing Removal and Installation Tool (RR1075TR) and Universal Driver Handle (OE8044-T0) onto Main Shaft Bearing.

12. Press Main Shaft Bearing out of Main Housing.

NOTICE: Support the Main Housing to avoid damaging the housing and sealing surface.

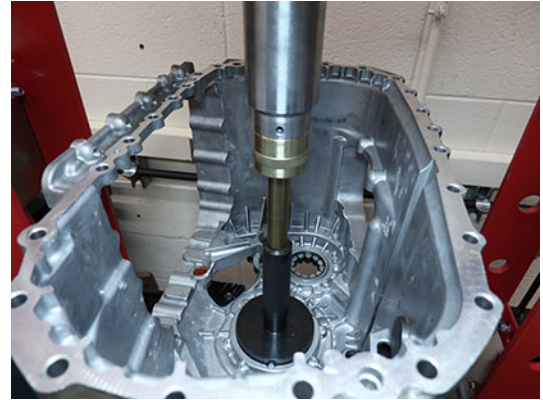

13. Place Main Housing vertically in press and support housing on Oil Pump Assembly surface.



14. Place Countershaft Bearing Installer (RR1076TR) and Universal Driver Handle (OE8044-T0) onto Rear Lower Countershaft Bearing.

15. Press Rear Lower Countershaft Bearing out of Main Housing.

NOTICE: Support the Main Housing to avoid damaging the housing and sealing surface.



16. If present, remove Countershaft Bearing O-ring and discard.

Note: Install new Countershaft Bearing O-rings when assembling Main Housing with chamfered bearing bores.



Assemble the Main Housing

1. Install Main Housing in press vertically with the Main and Clutch Housing mating surface down.

NOTICE: Ensure Main Housing is sitting flat on sealing surface to avoid damaging the housing.

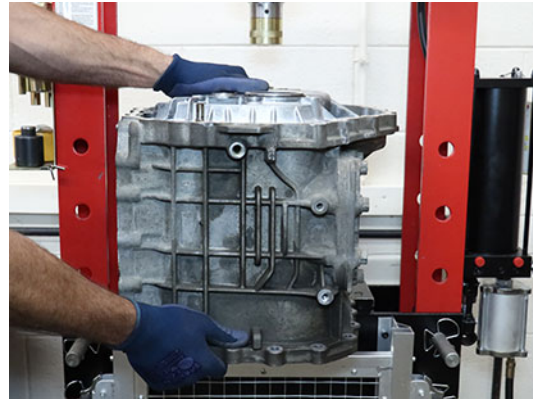

2. Place Main Shaft Bearing into Main Housing.
3. Place Main Shaft Bearing Installer (RR1077TR) and Universal Driver Handle (OE8044-T0) onto Main Shaft Bearing.
4. Press Main Shaft Bearing into Main Housing.

NOTICE: Support the Main Housing to avoid damaging the housing and sealing surface.

NOTICE: Do not over press bearing into Main Housing. Over pressing could result in component damage.



5. Verify Main Shaft Bearing is fully seated into housing.



6. Inspect Rear Lower Countershaft Bearing and verify snap ring is fully seated in groove.



7. Inspect Rear Lower Countershaft bearing bore for chamfered edge.

- If chamfer is present, go to Step 8.
- If chamfer is NOT present, go to Step 9.



8. Slide Countershaft Bearing O-ring on Rear Lower Countershaft Bearing until fully seated against snap ring.

Note: Install new Countershaft Bearing O-rings when assembling Main Housing with chamfered bearing bores.



9. Place Main Housing Lower Bearing template cut out on Main Housing opening.

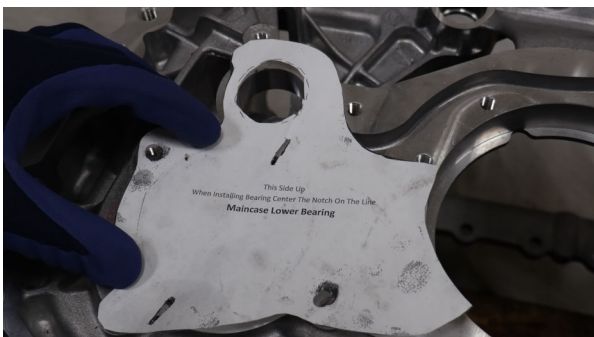

10. Complete marks that are 180 degrees apart using the slots on the template.



11. Place Rear Lower Countershaft Bearing into Main Housing, aligning flat spots on bearing to both marks.



12. Place Countershaft Bearing Installer (RR1076TR) and Universal Driver Handle (OE8044-T0) onto Rear Lower Countershaft Bearing.

13. Press Rear Lower Countershaft Bearing into Main Housing until fully seated.

NOTICE: Support the Main Housing to avoid damaging the housing and sealing surface.

NOTICE: Do not over press bearing into Main Housing. Over pressing could result in component damage and/or personal injury.



14. Verify Rear Lower Countershaft Bearing is fully seated into housing.



15. Inspect Rear Upper Countershaft Bearing and verify snap ring is fully seated in groove.



16. Inspect Rear Upper Countershaft bearing bore for chamfered edge.

- If chamfer is present, go to Step 17.
- If chamfer is NOT present, go to Step 18.

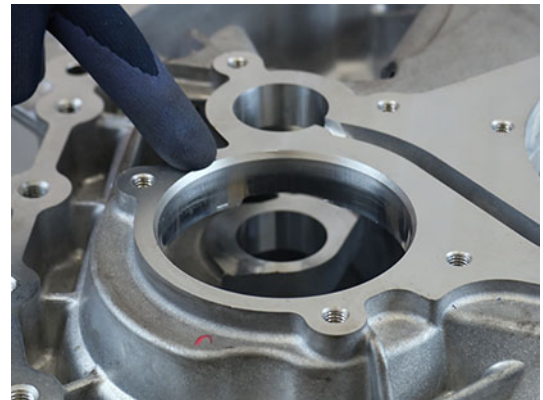

17. Slide Countershaft Bearing O-ring on Rear Upper Countershaft Bearing until fully seated against snap ring.

Note: Install new Countershaft Bearing O-rings when assembling Main Housings with chamfered bearing bores.



18. Place Main Housing Upper Bearing template cut-out on Main Housing opening.



19. Complete marks that are 180 degrees apart using the slots on the template.



20. Place Rear Upper Countershaft Bearing into Main Housing, aligning flat spots on bearing to both marks.



21. Place Countershaft Bearing Installer (RR1076TR) and Universal Driver Handle (OE8044-T0) onto Rear Upper Countershaft Bearing.

22. Press Rear Upper Countershaft Bearing into Main Housing until fully seated.

NOTICE: Support the Main Housing to avoid damaging the housing and sealing surface.

NOTICE: Do not over press bearing into Main Housing. Over pressing could result in component damage and/or personal injury.



23. Verify Rear Upper Countershaft Bearing is fully seated into housing.



24. Install bearing into Upper Reverse Idler Gear.



25. Install and hold Upper Reverse Idler Gear upper washer into Main Housing.



26. While holding the upper washer, install Upper Reverse Idler Gear, bearing and lower washer into Main Housing.

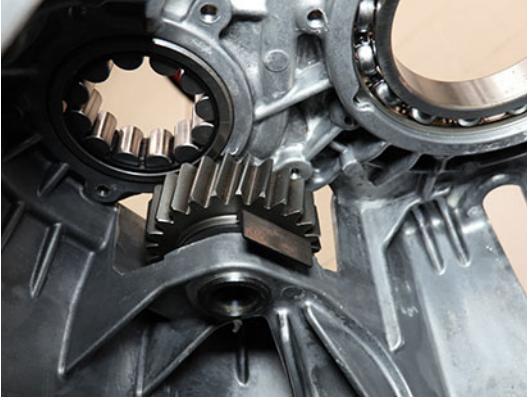

27. Install Upper Reverse Idler Gear Shaft by pushing shaft into housing, through washers, bearing and gear.



28. Align pin with passage in housing until pin is fully seated into passage.

Note: If necessary, use a soft faced hammer to lightly tap shaft into housing.



29. Install bearing into Lower Reverse Idler Gear.



30. Install and hold Lower Reverse Idler Gear upper washer into Main Housing.



31. While holding the upper washer, install Lower Reverse Idler Gear, bearing and lower washer into Main Housing.



32. Install Lower Reverse Idler Gear Shaft by pushing shaft into housing, through washers, bearing and gear.



33. Align pin with passage in housing until pin is fully seated into passage.

Note: If necessary, use a soft faced hammer to lightly tap shaft into housing.



Install the Fluid Pressure Sensor (FPS)

1. Inspect the Fluid Pressure Sensor (FPS) and O-ring for damage. If damaged, replace the FPS; O-ring is serviced with sensor.



2. Install the Transmission FPS (24 mm) into the Main Housing and torque to 19-23 Nm (14-17 lb-ft).

Note: There are two possible Main Housing FPS port designs. FPS removal and installation have the same procedure for both designs.



3. Connect and latch the OEM 3-Way Transmission FPS Connector.

Rear Housing

Special Instructions



WARNING: Rear Housing weighs approximately 170 lbs. Keep fingers clear of pinch point between Rear Housing and other surfaces. Dropping Rear Housing could result in major vehicle component damage, severe injury or death.

Special Tools

- Reaction Plate Alignment Pins (RR1091TR)
- Range Assembly Removal & Installation Tool (RR1065TR)
- Rear Housing Stand (RR1069TR)
- Input Shaft Bearing Removal and Installation Tool (RR1075TR)
- Output Bearing Removal and Installation Tool (RR1089TR)
- Universal Driver Handle (OE8044-T0)

Component Identification

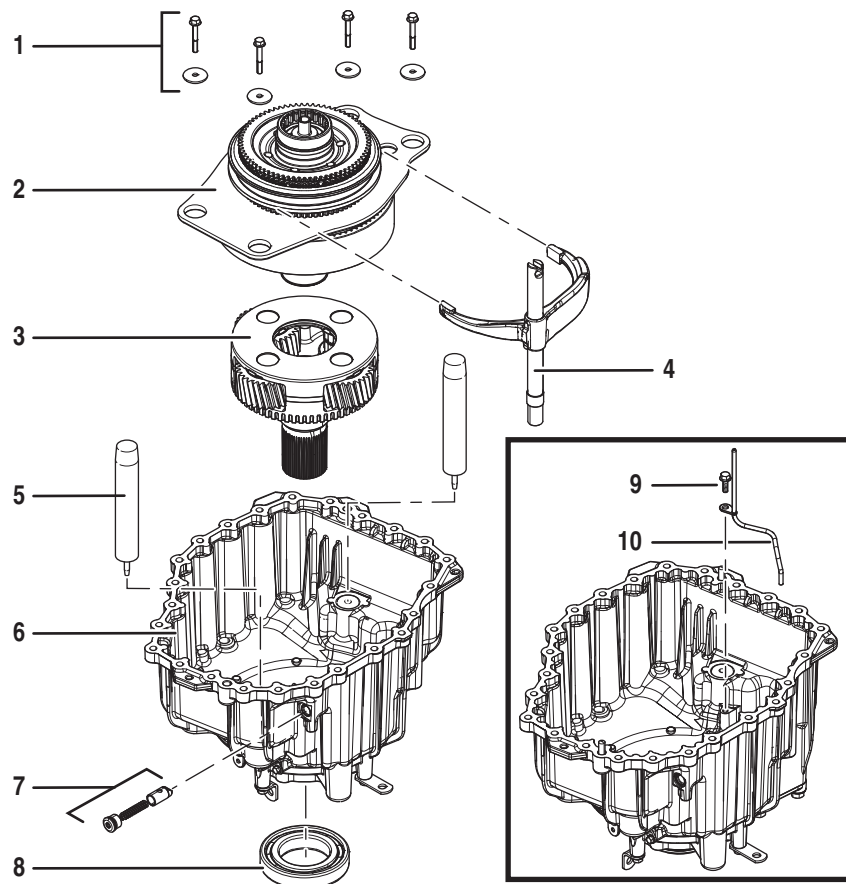

1. Cap Screws and Washers (x4) - 13 mm
2. Range Synchronizer Assembly
3. Planetary Output Shaft Assembly
4. Shift Rail E
5. Reaction Plate Alignment Pins (x2)

6. Rear Housing
7. Rail E Detent
8. Output Bearing
9. Cap Screw (x1) - 8 mm
10. Rear PTO Lube Tube (Dual PTO model only)

Remove the Rear Bearing Cover

1. Remove the 8 Rear Bearing Cover 13 mm Cap Screws.



2. Using a pry bar, separate the Rear Bearing Cover from the rear housing.

Note: Two pry points located at 12 and 6 o'clock.

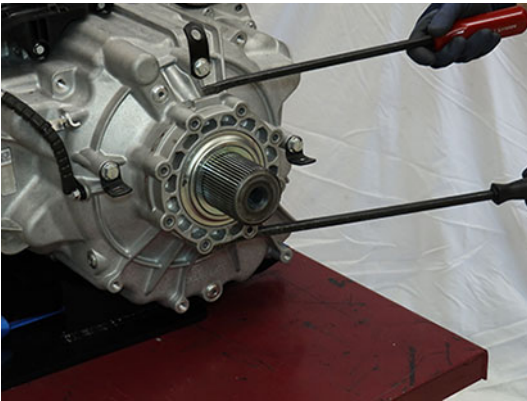

3. Remove the Rear Bearing Cover, Wear Sleeve and Dust Cover.

NOTICE: If replacing the Output Seal, a new Rear Bearing Cover is required when reinstalling or an oil leak may occur.

NOTICE: Ensure Output Shaft Seal is pressed in new Rear Bearing Cover.

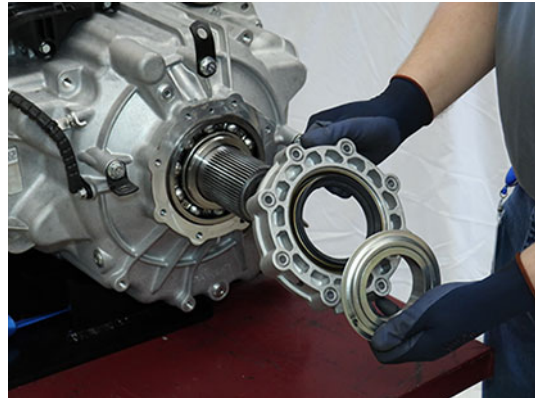
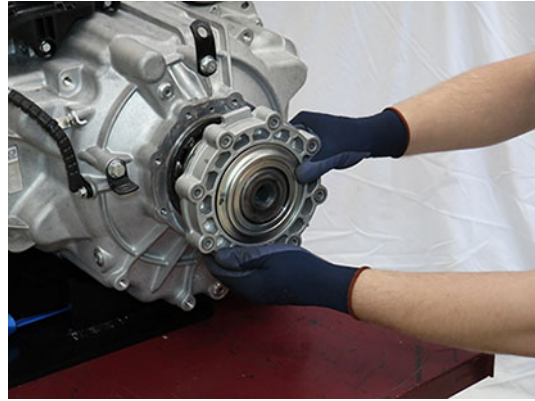

4. Remove the O-ring.



5. Remove the Output Shaft Thrust Washer.



Disassemble the Rear Housing

1. Place Rear Housing on Rear Housing Stand (RR1069TR).



WARNING: Rear Housing weighs approximately 170 lbs. Keep fingers clear of pinch point between Rear Housing and other surfaces. Dropping Rear Housing may result in major vehicle component damage, severe injury or death.



2. Remove Rail E Detent Plug with a 6 mm hex key.

Note: Detent Plug is under spring pressure.



3. Remove the Rail E Spring and Detent using a magnet.



4. Remove 4 Reaction Plate 13 mm cap screws and washers.

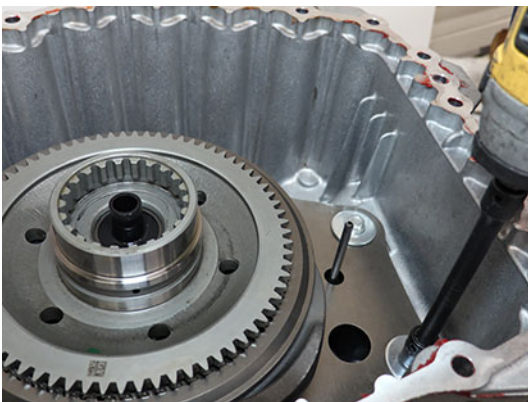

5. Install 2 Reaction Plate Alignment Pins (RR1091TR) onto Reaction Plate dowels.

NOTICE: Failure to use Reaction Plate Alignment Pins (RR1091TR) results in component damage.



6. Install Range Assembly Removal & Installation Tool (RR1065TR) into Sun Gear groove.



CAUTION: Failure to properly secure tool could result in damage to component(s) or personal injury.

NOTICE: Fully seat tool into groove and hand tighten until tool is secure.



7. Lift and remove Range Synchronizer Assembly from Rear Housing.



CAUTION: Range Synchronizer Assembly weighs approximately 70 lbs. Failure to properly secure and lift the assembly may result in component damage, serious injury or death.

NOTICE: Use an appropriate lifting device to safely lift component.

Note: Rotate Sun Gear to ease removal.

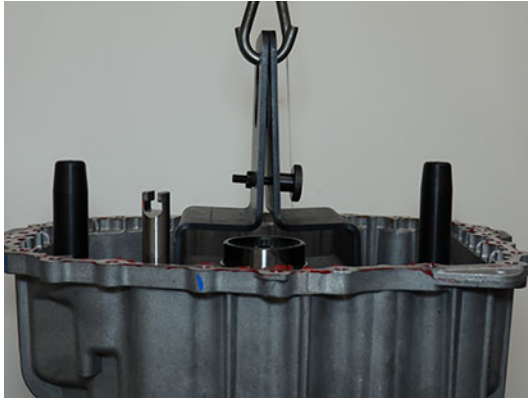

8. Hold Shift Rail E to the Range Synchronizer while removing Range Synchronizer Assembly from Rear Housing.



9. After Range Synchronizer Assembly clears the housing, remove Shift Rail E.



10. Remove Reaction Plate Alignment Pins (RR1091TR).



11. For Dual PTO transmissions, remove the Rear PTO Lube Tube 8 mm cap screw and remove tube.



12. Place Rear Housing in press with Output Shaft up.



CAUTION: Rear Housing with the Planetary Output Shaft Assembly weighs approximately 60 lbs. Keep fingers clear of pinch point between Rear Housing and other surfaces. Dropping Rear Housing could result in component damage and/or personal injury.

NOTICE: Place soft material under Planetary Output Shaft Assembly to cushion removal from Rear Housing.

NOTICE: Support the Rear Housing to avoid damaging the housing and sealing surface.

13. Press Planetary Output Shaft Assembly out of Rear Housing.

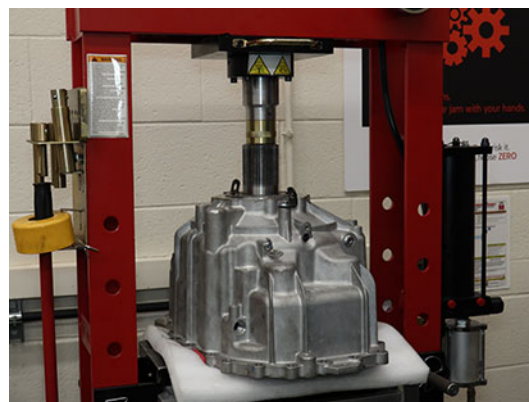

14. Remove Rear Housing and Planetary Output Shaft Assembly from press.



CAUTION: Rear Housing with the Planetary Output Shaft Assembly weighs approximately 60 lbs. Keep fingers clear of pinch point between Rear Housing and other surfaces. Dropping Rear Housing and Planetary Output Shaft Assembly could result in component damage and/or personal injury.

15. Install Rear Housing in press and support housing on Rear Bearing Cover sealing surface.



CAUTION: Rear Housing weighs approximately 15 lbs. Keep fingers clear of pinch point between Rear Housing and other surfaces. Dropping the Rear Housing may result in major vehicle component damage, severe injury or death.

NOTICE: Support the Rear Housing to avoid damaging the housing and sealing surface.

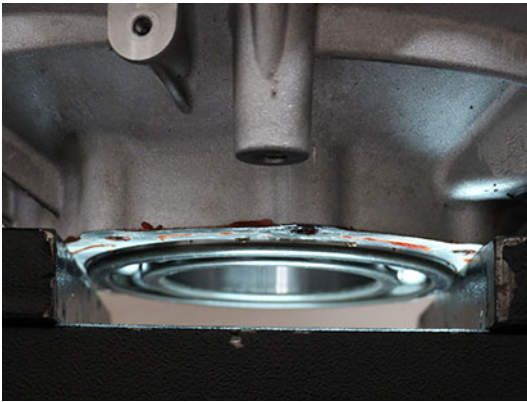

17. Press Output Bearing from Rear Housing.



16. Place Output Bearing Removal and Installation Tool (RR1089TR) and Universal Driver Handle (OE8044-T0) onto Output Bearing.



Assemble the Rear Housing

1. Place Rear Housing into press.
2. Place Output Bearing onto Rear Housing.



3. Place Output Bearing Removal and Installation tool (RR1089TR) onto Output Bearing.

NOTICE: Do not over press bearing into Rear Housing. Over pressing could result in component damage.

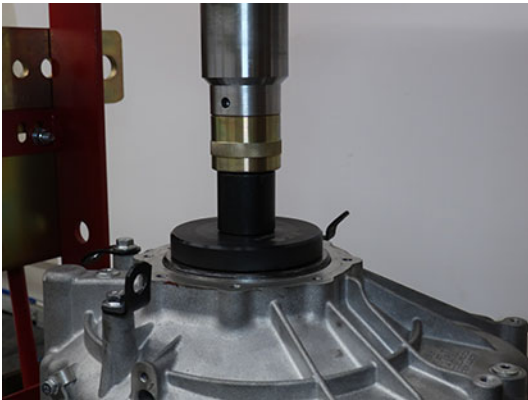

4. Press Output Bearing into Rear Housing.

5. Verify Output Bearing is fully seated.



6. Place Rear Housing Stand (RR1069TR) on Press.

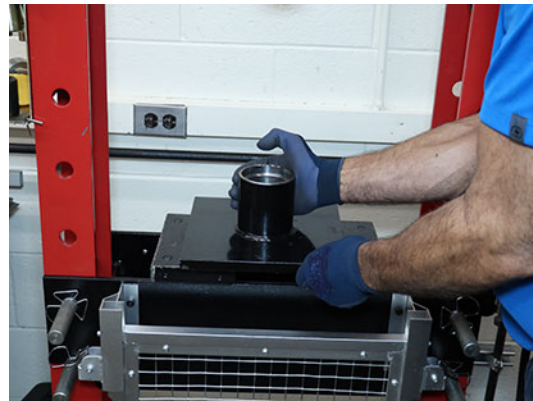

- Place Rear Housing on Rear Housing Stand (RR1069TR).



CAUTION: Rear Housing weighs approximately 15 lbs. Keep fingers clear of pinch point between Rear Housing and other surfaces. Dropping Rear Housing could result in component damage and/or personal injury.



- Place Planetary Output Shaft Assembly into Output Bearing.



CAUTION: Planetary Output Shaft Assembly weighs approximately 45 lbs. Keep fingers clear of pinch point between Planetary Output Shaft Assembly and other surfaces. Dropping Planetary Output Shaft Assembly could result in component damage and/or personal injury.



- Place Input Shaft Bearing Removal and Installation Tool (RR1075TR) onto Planetary Output Shaft Assembly.

- Press Planetary Output Shaft Assembly through output bearing until fully seated.



- Remove Rear Housing from press.



CAUTION: Rear Housing with the Planetary Output Shaft Assembly weighs approximately 60 lbs. Keep fingers clear of pinch point between Rear Housing and other surfaces. Dropping Rear Housing and Planetary Output Shaft Assembly could result in component damage and/or personal injury.

- Verify Planetary Output Shaft Assembly is fully seated in Output Bearing.



13. Place rear housing on Rear Housing Stand (RR1069TR).



14. For Dual PTO Transmissions, install Rear PTO Lube Tube and 8 mm cap screw into Rear Housing and torque to 8.8 - 10.4 Nm (6-8 lb-ft).



15. Install Reaction Plate Alignment Pins (RR1091TR) in Rear Housing.

NOTICE: Failure to use Reaction Plate Alignment Pins (RR1091TR) results in component damage.



16. Inspect plastic Oil Slinger to ensure it is locked into place by three locking tab pins.



17. Install Range Assembly Removal & Installation Tool (RR1065TR) into Sun Gear groove.



CAUTION: Failure to properly secure tool could result in component damage or personal injury.

NOTICE: Fully seat tool into groove and hand tighten until tool is secure.

18. Lift Range Synchronizer Assembly with Range Assembly Removal & Installation tool (RR1065TR).



CAUTION: Range Synchronizer Assembly weighs approximately 70 lbs. Failure to properly secure and lift the assembly may result in component damage, serious injury or death.

NOTICE: Use an appropriate lifting device to safely lift component.



19. Install and hold Shift Rail E to Range Synchronizer Assembly.

Note: Ensure the notched end of Shift Rail E is facing up.

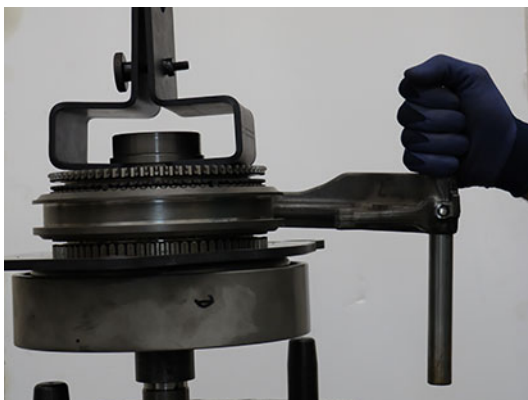

20. Lower the Range Synchronizer Assembly and Shift Rail E into Rear Housing.

Note: Align Range Synchronizer Assembly to the Reaction Plate Alignment Pins (RR1091TR) and Shift Rail E into Rear Housing.

Note: Rotate Sun Gear to ease installation.

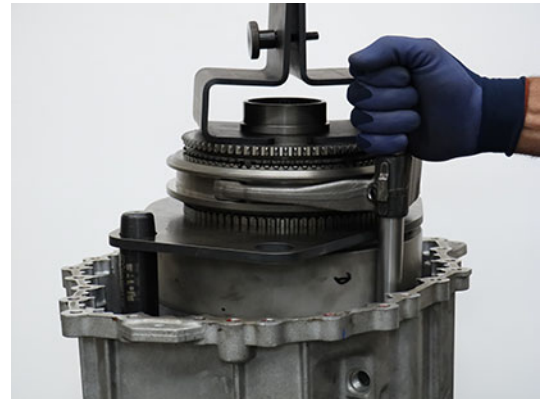

21. Remove Range Assembly Removal and Installation tool (RR1065TR).



22. Remove Reaction Plate Alignment Pins (RR1091TR).



23. Install 4 Reaction Plate cap screws and washers and torque to 21 - 25 Nm (16 - 19 lb-ft).



25. Torque detent plug to 24.5 - 29.5 Nm (16-19 lb-ft).

NOTICE: Do not over-torque detent plug or transmission damage may occur.



24. Install Rail E Detent, Spring and Plug.

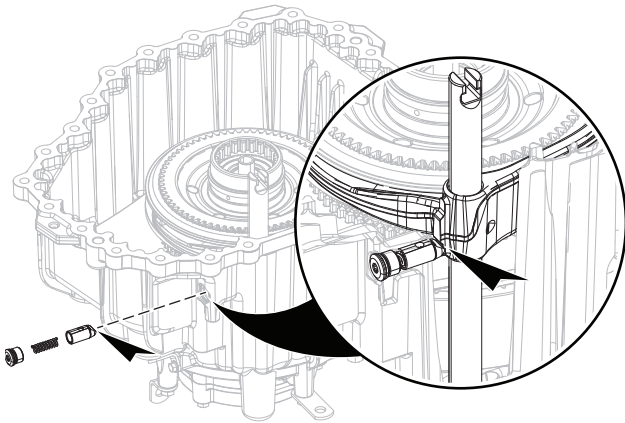

Clutch Housing

Special Instructions

Clutch Housing is approximately 558 mm (22 inches) wide. Only perform steps to **Disassemble Clutch Housing** and **Assemble Clutch Housing** when using a press. If the Clutch Housing is too large for the available press, perform steps to **Disassemble Clutch Housing with Input Shaft Press (RR1085TR)** and **Assemble Clutch Housing with Input Shaft Press (RR1085TR)**.

Note: A press is required for the removal and installation of the Input Shaft. Failure to use a press could result in Input Shaft and/or Clutch Housing damage.

Note: For Bearing Lock installation, print the Bearing Lock templates from the appendix. Cut out the three templates for both Clutch Housing Countershaft bearings and Front Input Shaft bearing. All three templates will be used to mark bearing openings to properly place bearings in Clutch Housing.

Special Tools

- Countershaft Bearing Installer (RR1076TR)
- Input Shaft Cup (RR1085TR-6)
- Front Bearing Capture Plate (RR1085TR-7)
- Input Shaft Bearing Removal and Installation Tool (RR1075TR)
- Universal Driver Handle (OE8044-T0)

Note: If manually pressing the Input Shaft, additional tools are needed:

- Input Shaft Press (RR1085TR)
- Input Bearing Driver (RR1049TR)
- 4 (2 inch 7/16 inch Grade 8 or 50.8 mm M12 Grade 10.9) cap screws, washers and nuts

Note: Reference the appendix for Clutch Housing Bearing Templates on page 462.

Component Identification

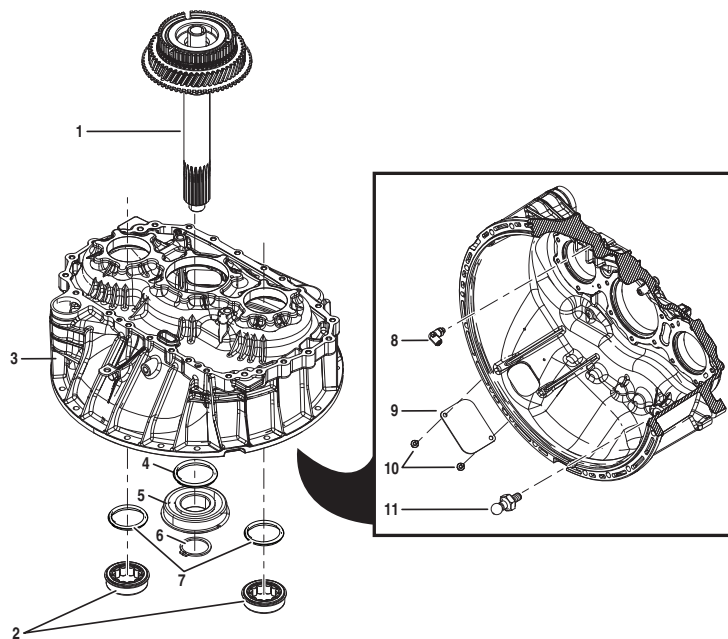

1. Input Shaft Assembly
2. Countershaft Bearings (x2)
3. Clutch Housing
4. Input Shaft Bearing O-ring
5. Input Shaft Bearing
6. Input Shaft Snap Ring

7. Countershaft Bearing O-rings (x2) (Only use with Chamfered Bearing Bores)
8. 90-Degree Air Line Fitting
9. Inspection Cover
10. Cap Screws (x2)
11. Release Yoke Pivot Pin

Disassemble Clutch Housing

1. Ensure Input Shaft Snap Ring is removed.
2. Place Clutch Housing in press with Input Shaft up.



CAUTION: Clutch Housing weighs approximately 50 lbs. Keep fingers clear of pinch points between Clutch Housing and other surfaces. Dropping Clutch Housing could result in component damage and/or personal injury.

NOTICE: A press is required for the removal and installation of the Input Shaft. Failure to use a press results in Input Shaft and/or Clutch Housing damage.

NOTICE: Support the Clutch Housing to avoid damaging the housing and sealing surface.

Note: Clutch Housing is approximately 558 mm (22 inches) wide. If Clutch Housing is too large for the available press, perform steps to **Disassemble Clutch Housing with Input Shaft Press (RR1085TR)** and **Assemble Clutch Housing with Input Shaft Press (RR1085TR)**.



3. Place Input Shaft Cup (RR1085TR-6) on the end of the Input Shaft.



4. Press Input Shaft from Clutch Housing.



5. Mark Clutch Housing to indicate airline inlet direction with a paint mark.



6. Remove Inertia Brake 90-degree airline elbow (15 mm).



7. Remove the Release Yoke Pivot Pin (30 mm).



8. Place Clutch Housing in press with flywheel housing side of the Clutch Housing down.

NOTICE: Support the Clutch Housing to avoid damaging the housing.

9. Place Input Shaft Bearing Removal and Installation Tool (RR1075TR) and Universal Driver Handle (OE8044-T0) onto Input Shaft Bearing.

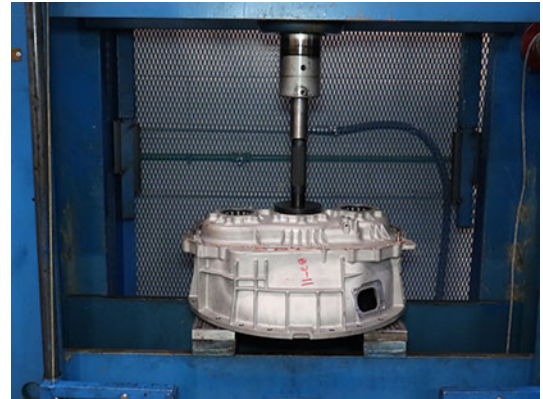

10. Press Input Shaft Bearing from Clutch Housing.

11. If present, remove Input Shaft Bearing O-ring and discard.

Note: Install a new Input Shaft Bearing O-ring when assembling Clutch Housing with chamfered bearing bores.



12. Place Countershaft Bearing Installer (RR1076TR) and Universal Driver Handle (OE8044-T0) onto Lower Countershaft Bearing.

13. Press Lower Countershaft Bearing from Clutch Housing.



16. Press Upper Countershaft Bearing from Clutch Housing.



14. If present, remove Countershaft Bearing O-ring and discard.

Note: Install new Countershaft Bearing O-rings when assembling Clutch Housing with chamfered bearing bores.



17. If present, remove Countershaft Bearing O-ring and discard.

Note: Install new Countershaft Bearing O-rings when assembling Clutch Housing with chamfered bearing bores.



15. Place Countershaft Bearing Installer (RR1076TR) and Universal Driver Handle (OE8044-T0) onto Upper Countershaft Bearing.

Assemble Clutch Housing



CAUTION: Clutch Housing (without Input Shaft) weighs approximately 40 lbs. Keep fingers clear of pinch point between Clutch Housing and other surfaces. Dropping Clutch Housing could result in component damage and/or personal injury.

1. Place Clutch Housing in press with flywheel housing side up.
2. Inspect Upper Countershaft bearing bore for chamfered edge.
 - If chamfer is present, go to Step 3.
 - If chamfer is NOT present, go to Step 4.



3. Slide Countershaft Bearing O-ring on Upper Countershaft Bearing until fully seated against snap ring.

Note: Install new Countershaft Bearing O-rings when assembling Clutch Housing with chamfered bearing bores.



4. Place Clutch Housing Upper Bearing template cut out on Clutch Housing opening.

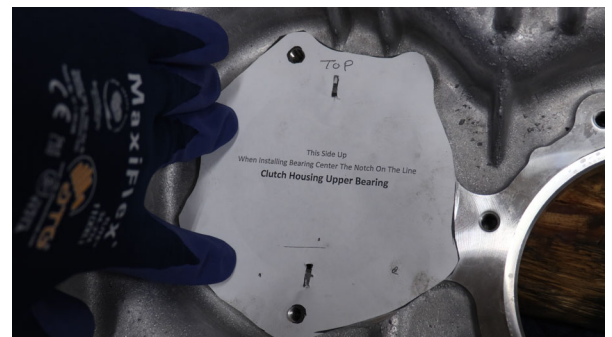

5. Complete marks that are 180 degrees apart using the slots on the template.

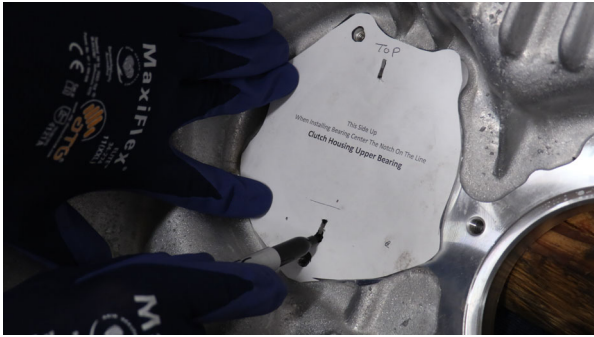

6. Place Upper Countershaft Bearing into Clutch Housing, aligning flat spots on bearing to both marks.



7. Press Upper Countershaft Bearing into Clutch Housing, aligning flat spots on bearing to both marks.

NOTICE: Do not over press bearing into Clutch Housing. Over pressing could result in component damage.



8. Verify Upper Countershaft Bearing is fully seated in Clutch Housing.

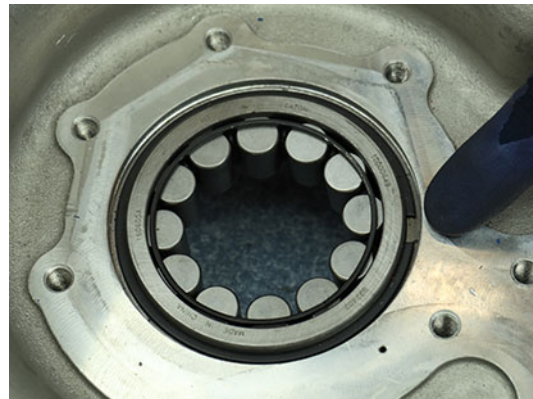

9. Inspect Lower Countershaft bearing bore for chamfered edge.
- If chamfer is present, go to Step 9.
 - If chamfer is NOT present, go to Step 10.



10. Slide Countershaft Bearing O-ring on Lower Countershaft Bearing until fully seated against snap ring.
- Note:** Install new Countershaft Bearing O-rings when assembling Clutch Housing with chamfered bearing bores.



11. Place Clutch Housing Lower Bearing template cut out on Clutch Housing opening.



12. Complete marks that are 180 degrees apart using the slots on the template.



13. Place Lower Countershaft Bearing into Clutch Housing, aligning flat spots on bearing to both marks.



14. Place Countershaft Bearing Installer (RR1076TR) and Universal Driver Handle (OE8044-T0) onto Lower Countershaft Bearing.
15. Place Lower Countershaft Bearing into Clutch Housing, aligning flat spots on bearing to both marks.

16. Press Lower Countershaft Bearing into Clutch Housing.

NOTICE: Do not over press bearing into Clutch Housing. Over pressing could result in component damage.



17. Verify Lower Countershaft Bearing is fully seated in Clutch Housing.



18. Inspect Input Shaft bearing bore for chamfered edge.

- If chamfer is present, go to Step 19.
- If chamfer is NOT present, go to Step 20.

**19.** Slide Input Shaft Bearing O-ring on Input Shaft Bearing until fully seated against snap ring.

Note: Install a new Input Shaft Bearing O-ring when assembling Clutch Housing with chamfered bearing bores.

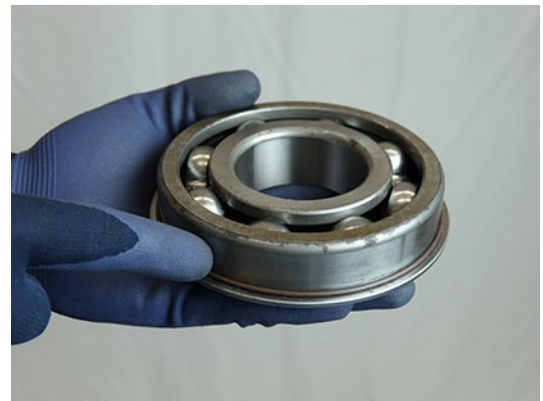
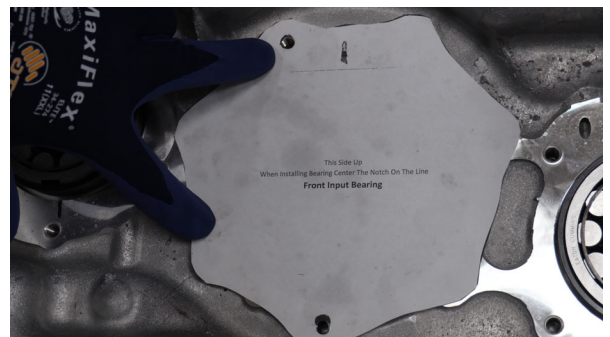
**20.** Place Clutch Housing Front Input Bearing template cut-out on Clutch Housing opening.

21. Complete mark on the slot of the template.



22. Place Input Bearing into Clutch Housing, aligning flat spot on bearing to mark.



23. Place Input Shaft Bearing Removal and Installation Tool (RR1075TR) and Universal Driver Handle (OE8044-T0) onto Input Shaft Bearing.

24. Press Input Shaft Bearing into Clutch Housing until fully seated.

NOTICE: Do not over press bearing into Clutch Housing. Over pressing could result in component damage.

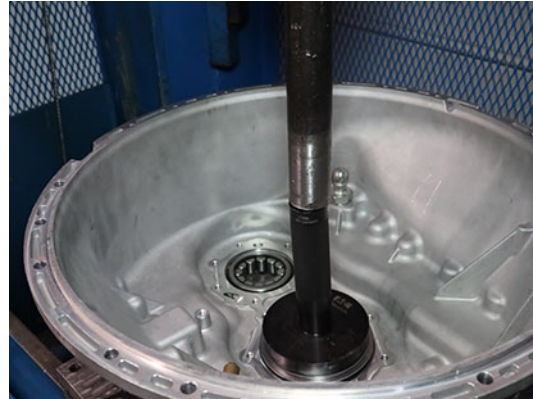

25. Verify Input Shaft Bearing is fully seated in Clutch Housing.



26. Install and hand tighten Inertia Brake 90-degree airline elbow (15 mm) aligning airline inlet with paint mark.



27. Install Release Yoke Pivot Pin (30 mm) and torque to 130-140 Nm (95-101 lb-ft).



28. Place Clutch Housing in press with flywheel housing side of the Clutch Housing down on Input Shaft Stand (RR1073TR), supporting the Inner Bearing Race of the Input Shaft Bearing.

NOTICE: Support the Inner Bearing Race to avoid damaging the Input Shaft Bearing in the Clutch Housing.

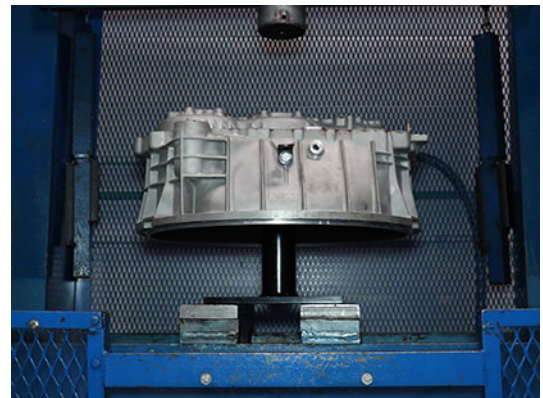
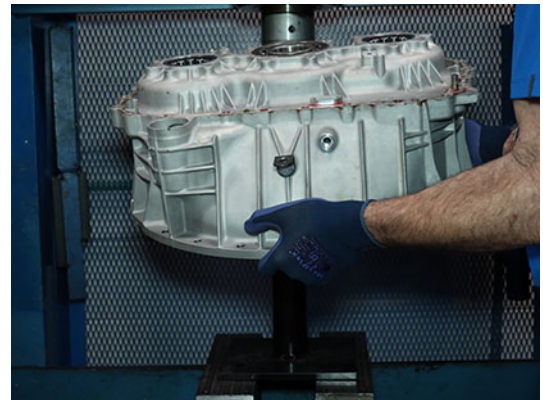

29. Install Input Shaft into Clutch Housing.



30. Place Input Shaft Cup (RR1085TR-6) on the Input Shaft.



31. Press Input Shaft into Input Shaft Bearing until fully seated.

NOTICE: Do not over press Input Shaft into Clutch Housing. Over pressing could result in component damage.



32. Install Input Shaft Snap Ring.

NOTICE: A new snap ring is required when reinstalling. A used snap ring may detach from Input Shaft and result in transmission component damage.

Note: The snap ring will not install if Input Shaft is not fully seated into Input Shaft Bearing.



Install Input Shaft Cover

1. Clean sealing surfaces on the Clutch Housing and Input Shaft Cover.
2. Slide the Input Shaft Cover over the Input Shaft.

Note: Align "TOP" at 12 o'clock.



3. Install the 7 Input Shaft Cover 13 mm cap screws and torque to 21-25 Nm (16-19 lb-ft) in a criss-cross pattern.



Disassemble Clutch Housing with Input Shaft Press (RR1085TR)

1. Ensure Input Shaft Snap Ring is removed.
2. Place and support Clutch Housing on a bench.

Note: Allow space to press the Input Shaft out of Clutch Housing.



3. Place Input Shaft Cup (RR1085TR-6) on the end of the Input Shaft.



- Place Input Shaft Press (RR1085TR) on the flywheel housing side of the Clutch Housing.



CAUTION: Input Shaft Press weighs approximately 30 lbs. Keep fingers clear of pinch point between Input Shaft Press and other surfaces. Dropping Input Shaft Press could result in component damage and/or personal injury.

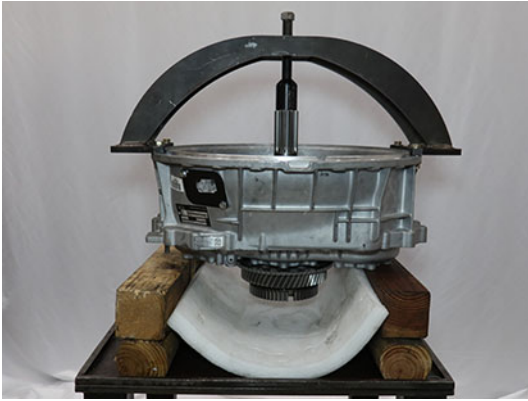

- Install and hand tighten 4 (2 inch 7/16 inch Grade 8 or 50.8 mm M12 Grade 10.9) cap screws, washers and nuts to attach press to housing.



- Place soft material under Input Shaft.



- Rotate jack screw to press Input Shaft out of Clutch Housing.
- Remove 4 cap screws, washers, nuts and Input Shaft Press (RR1085TR) from Clutch Housing.



CAUTION: Input Shaft Press weighs approximately 30 lbs. Keep fingers clear of pinch points between Input Shaft Press and other surfaces. Dropping Input Shaft Press could result in component damage and/or personal injury.

- Mark Clutch Housing to indicate airline inlet direction with paint mark.



10. Remove Inertia Brake 90-degree airline elbow (15 mm).



11. Remove Release Yoke Pivot Pin (30 mm).



12. Place and support Clutch Housing on a bench.

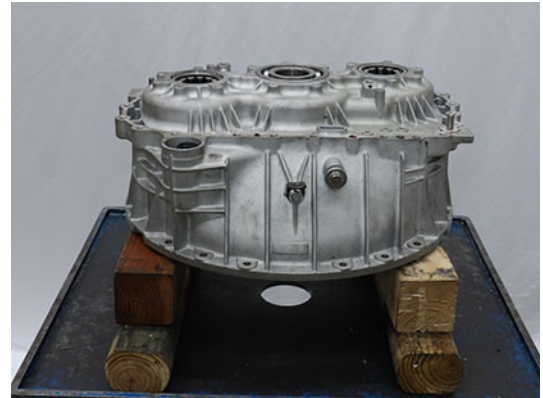

13. Install Input Shaft Press (RR1085TR) on the Main Housing side of the Clutch Housing aligning the 3 notches on the side of Linear Clutch Actuator opening.



CAUTION: Input Shaft Press weighs approximately 30 lbs. Keep fingers clear of pinch points between Input Shaft Press and other surfaces. Dropping Input Shaft Press could result in component damage and/or personal injury.

NOTICE: Protect Clutch Housing to Main Housing sealing surface from damage or an oil leak may occur.

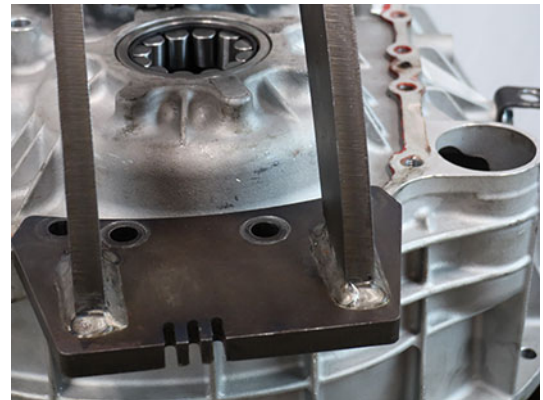

14. Install and hand tighten 4 Main Housing to Clutch Housing 16 mm cap screws in the inboard holes on each side of the press.

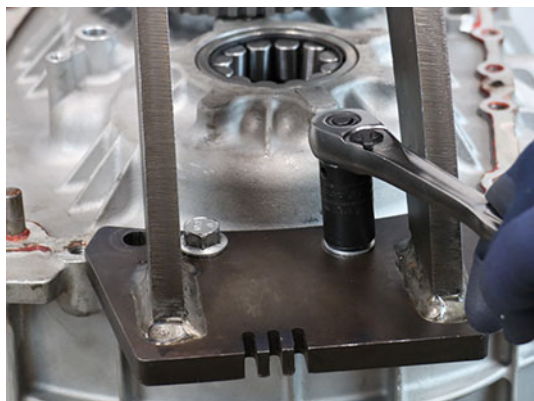

15. Place Input Shaft Bearing Removal and Installation Tool (RR1075TR) and Input Shaft Cup (RR1085TR-6) onto Input Shaft Bearing.

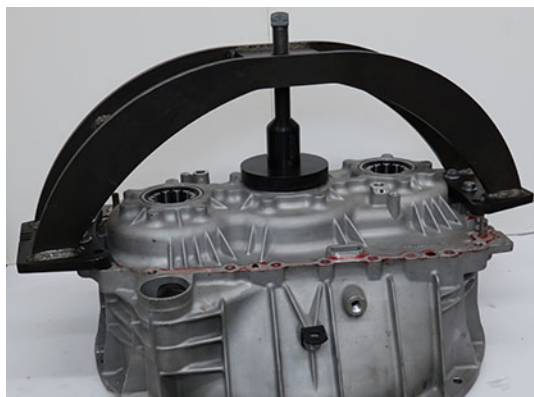

16. Rotate jack screw to press Input Shaft Bearing out of Clutch Housing.



17. If present, remove Input Shaft Bearing O-ring and discard.

Note: Install a new Input Shaft Bearing O-ring when assembling Clutch Housing with chamfered bearing bores.



18. Remove 4 cap screws, washers, nuts and Input Shaft Press (RR1085TR) from Clutch Housing



CAUTION: Input Shaft Press weighs approximately 30 lbs. Keep fingers clear of pinch points between Input Shaft Press and other surfaces. Dropping Input Shaft Press could result in component damage and/or personal injury.

19. Place Clutch Housing in press with flywheel housing side of the Clutch Housing down.

NOTICE: Support the Clutch Housing to avoid damaging the housing.

20. Place Countershaft Bearing Installer (RR1076TR) and Universal Driver Handle (OE8044-T0) onto Lower Countershaft Bearing.
21. Press Lower Countershaft Bearing from Clutch Housing.



22. If present, remove Countershaft Bearing O-ring and discard.

Note: Install new Countershaft Bearing O-rings when assembling Clutch Housing with chamfered bearing bores.



23. Place Countershaft Bearing Installer (RR1076TR) and Universal Driver Handle (OE8044-T0) onto Upper Countershaft Bearing.

24. Press Upper Countershaft Bearing from Clutch Housing.

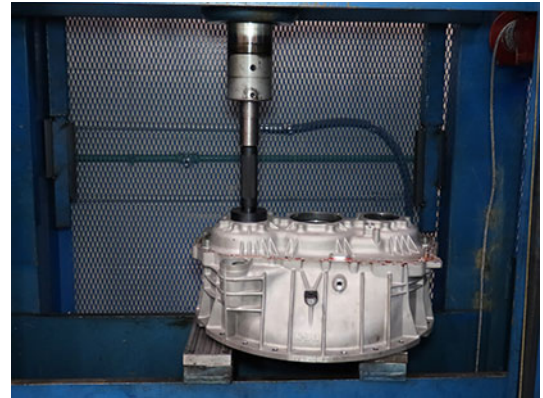

25. If present, remove Countershaft Bearing O-ring and discard.

Note: Install new Countershaft Bearing O-rings when assembling Clutch Housing with chamfered bearing bores.



Assemble Clutch Housing with Input Shaft Press (RR1085TR)



CAUTION: Clutch Housing (without Input Shaft) weighs approximately 40 lbs. Keep fingers clear of pinch point between Clutch Housing and other surfaces. Dropping Clutch Housing could result in component damage and/or personal injury.

1. Place Clutch Housing in press with flywheel housing side up.
2. Inspect Upper Countershaft bearing bore for chamfered edge
 - If chamfer is present, go to Step 3.
 - If chamfer is NOT present, go to Step 4.

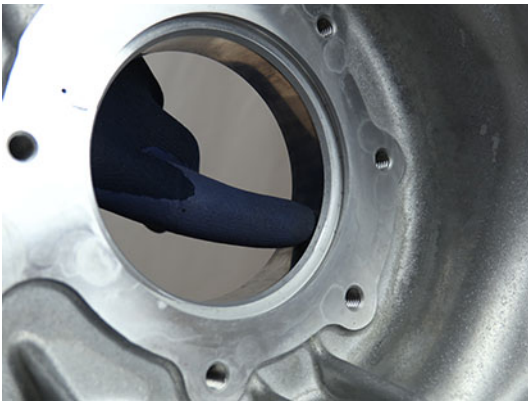

3. Slide Countershaft Bearing O-ring on Upper Countershaft Bearing until fully seated against snap ring.

Note: Install new Countershaft Bearing O-rings when assembling Clutch Housing with chamfered bearing bores.



4. Place Clutch Housing Upper Bearing template cut-out on Clutch Housing opening.

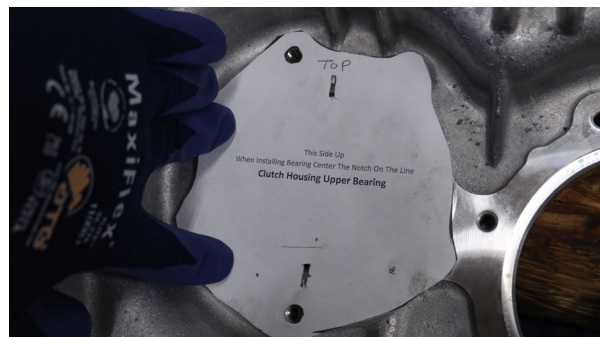

5. Complete marks that are 180 degrees apart using the slots on the template.

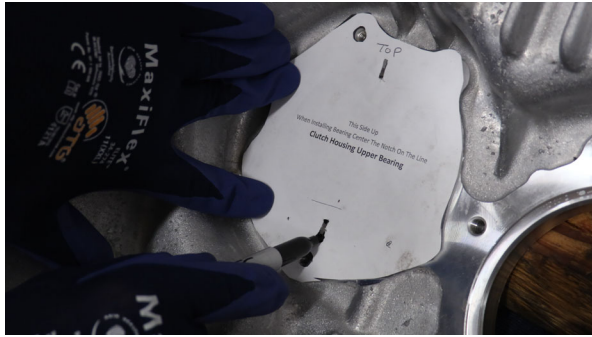

6. Place Upper Countershaft Bearing into Clutch Housing, aligning flat spots on bearing to both marks.



7. Place Countershaft Bearing Installer (RR1076TR) and Universal Driver Handle (OE8044-T0) onto Upper Countershaft Bearing.

8. Press Upper Countershaft Bearing into Clutch Housing.

NOTICE: Do not over press bearing into Clutch Housing. Over pressing could result in component damage.



9. Verify Upper Countershaft Bearing is fully seated in Clutch Housing.

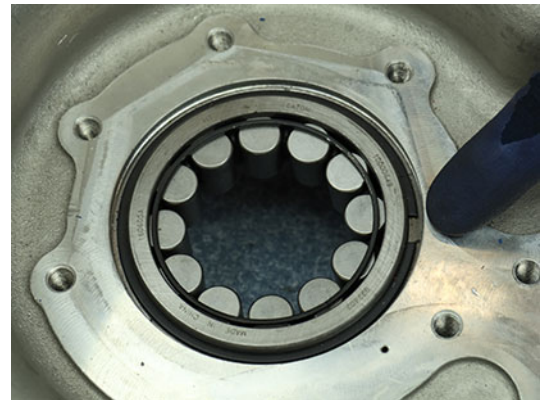

10. Inspect Lower Countershaft bearing bore for chamfered edge.
- If chamfer is present, go to Step 11.
 - If chamfer is NOT present, go to Step 12.



11. Slide Countershaft Bearing O-ring on Lower Countershaft Bearing until fully seated against snap ring.

Note: Install new Countershaft Bearing O-rings when assembling Clutch Housing with chamfered bearing bores.



12. Place Clutch Housing Lower Bearing template cut-out on Clutch Housing opening.



13. Complete marks that are 180 degrees apart using the slots on the template.



14. Place Lower Countershaft Bearing into Clutch Housing, aligning flat spots on bearing to both marks.



15. Place Countershaft Bearing Installer (RR1076TR) and Universal Driver Handle (OE8044-T0) onto Lower Countershaft Bearing.

16. Press Lower Countershaft Bearing into Clutch Housing.

NOTICE: Do not over press bearing into Clutch Housing. Over pressing could result in component damage.



17. Verify Lower Countershaft Bearing is fully seated in Clutch Housing.



18. Inspect Input Shaft bearing bore for chamfered edge.

- If chamfer is present, go to Step 19.
- If chamfer is NOT present, go to Step 22.

**19.** Slide Input Shaft Bearing O-ring on Input Shaft Bearing until fully seated against snap ring.

Note: Install a new Input Shaft Bearing O-ring when assembling Clutch Housing with chamfered bearing bores.

**20.** Place Input Shaft Press (RR1085TR) on the flywheel housing side of the Clutch Housing.

CAUTION: Input Shaft Press weighs approximately 30 lbs. Keep fingers clear of pinch point between Input Shaft Press and other surfaces. Dropping Input Shaft Press could result in component damage and/or personal injury.

21. Install and hand tighten 4 (2 inch 7/16 inch Grade 8 or 50.8 mm M12 Grade 10.9) cap screws, washers and nuts to attach press to housing.



22. Place Clutch Housing Front Input Bearing template cut-out on Clutch Housing opening.

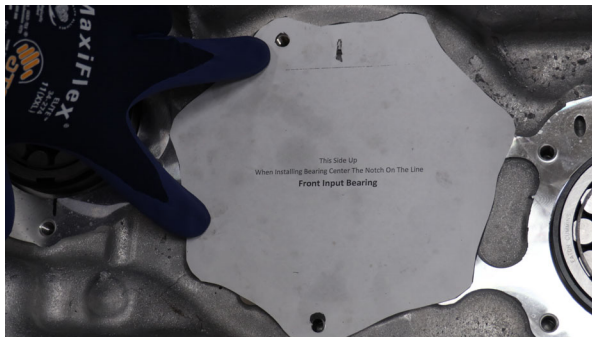

23. Complete mark on the slot of the template.



24. Place Input Bearing into Clutch Housing, aligning flat spot on bearing to mark.



25. Place Input Shaft Bearing Removal and Installation Tool (RR1075TR), Input Bearing Driver (RR1049TR) and Input Shaft Cup (RR1085TR-6) onto Input Shaft Bearing.

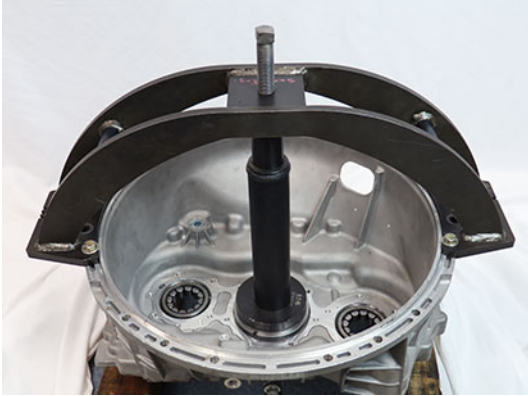

26. Rotate jack screw to press Input Shaft Bearing into Clutch Housing.

NOTICE: Do not over press bearing into Clutch Housing. Over pressing could result in component damage.

27. Remove Input Shaft Bearing Removal and Installation Tool (RR1075TR), Input Bearing Driver (RR1049TR) and Input Shaft Cup (RR1085TR-6).
28. Verify Input Shaft Bearing is fully seated in Clutch Housing.



29. Install and hand tighten Inertia Brake 90-degree airline elbow (15 mm) aligning airline inlet with paint mark.



30. Install Release Yoke Pivot Pin (30 mm) and torque to 130-140 Nm (95-101 lb-ft).



31. Install Front Bearing Capture Plate (RR1085TR-7) to the Clutch Housing using the Input Shaft Cover threaded mounting holes and hand tighten 4 plate cap screws with a 6 mm hex key.



32. Torque cap screws to 21-25 Nm (16-19 lb-ft) in a criss-cross pattern.
33. Place and support Clutch Housing on a bench.

Note: Allow space to press the Input Shaft into Clutch Housing.



34. Install Input Shaft into Clutch Housing.



35. Place Input Shaft Cup (RR1085TR-6) onto Input Shaft.



36. Install Input Shaft Press (RR1085TR) on the Main Housing side of the Clutch Housing aligning the 3 notches on the side of the Linear Clutch Actuator opening.



CAUTION: Input Shaft Press weighs approximately 30 lbs. Keep fingers clear of pinch points between Input Shaft Press and other surfaces. Dropping Input Shaft Press could result in component damage and/or personal injury.

NOTICE: Protect Clutch Housing to Main Housing sealing surface from damage or an oil leak may occur.

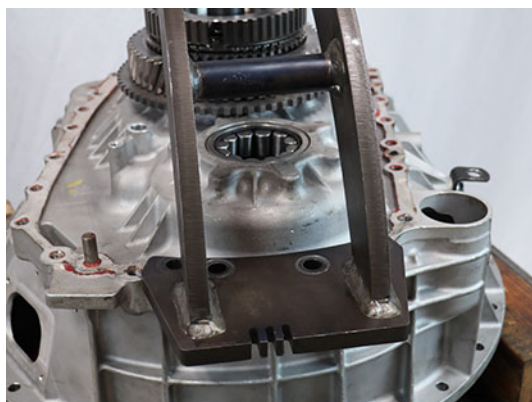

37. Install and hand tighten 4 Main Housing to Clutch Housing 16 mm cap screws in the inboard holes on each side of the press.

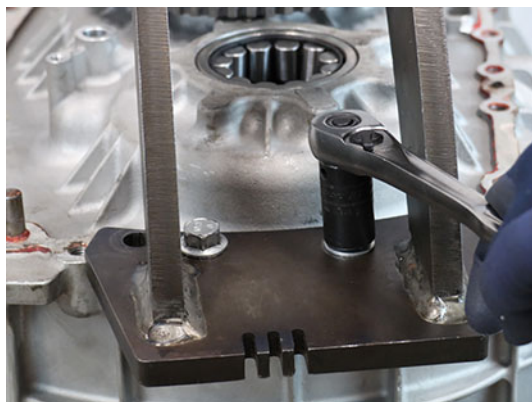

38. Rotate jack screw to press Input Shaft into Clutch Housing until fully seated.

NOTICE: Do not over press Input Shaft into Clutch Housing. Over pressing could result in component damage.



39. Remove 4 cap screws, washers, nuts, and Input Shaft Press (RR1085TR) from Clutch Housing.



CAUTION: Input Shaft Press weighs approximately 30 lbs. Keep fingers clear of pinch points between Input Shaft Press and other surfaces. Dropping Input Shaft Press could result in component damage and/or personal injury.

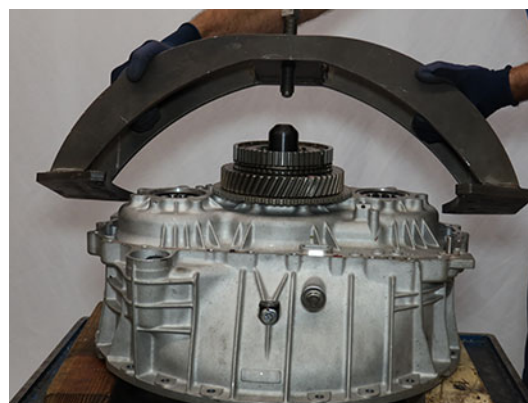

40. Remove Front Bearing Capture Plate (RR1085TR-7) from Clutch Housing.



41. Install Input Shaft Snap Ring

NOTICE: A new snap ring is required when reinstalling. A used snap ring may detach from Input Shaft and result in transmission component damage.

Note: The snap ring will not install if Input Shaft is not fully seated into Input Shaft Bearing.



Install Input Shaft Cover

1. Clean sealing surfaces on the Clutch Housing and Input Shaft Cover.
2. Slide the Input Shaft Cover over the Input Shaft.

Note: Align "TOP" at 12 o'clock.



3. Install the 7 Input Shaft Cover 13 mm cap screws and torque to 21-25 Nm (16-19 lb-ft) in a criss-cross pattern.



OEM and Engine Specific Kits

Clutch Service Kits

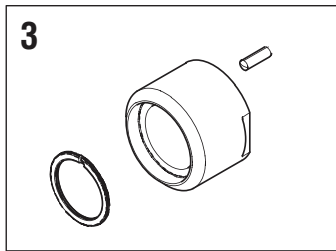
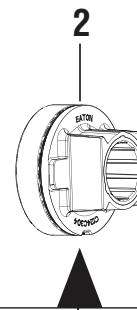
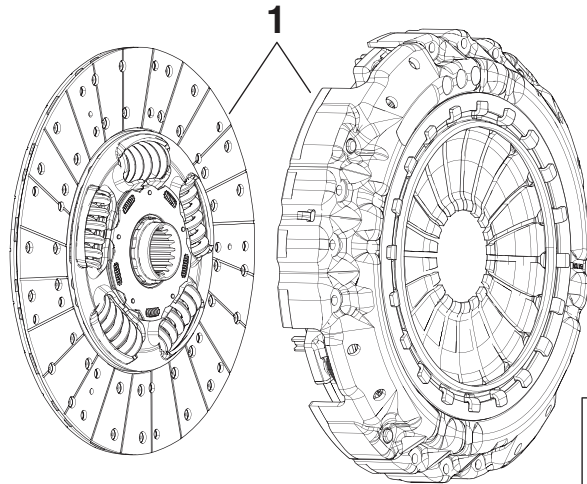

| | | |
|--------------------|-----------------------------|-----------------------------|
| Endurant HD and XD | A-10004340 (ISO) | A-10004341 (SAE) |
| | 125969 (ISO) | 125968 (SAE) |

1. Clutch Disc and Cover
2. Release Bearing
3. Input Shaft Repair Kit

Note: 125969 (ISO) and 125968 (SAE) are replaced by A-10004340 (ISO) and A-10004341 (SAE) effective March 2023.

| Transmission Model | OEM | Engine | Clutch Kit PN | Clutch Kit PN at PACCAR | Damper Size | Flywheel Bore | Release Bearing |
|--|------------------------------|----------------------------|--------------------------|-------------------------|-------------|---------------|-----------------|
| EEO-xxF112C EE-xxF112B EHD-xxF112C-N PO-xxF112C | Freightliner Western Star | Detroit DD13 (thru 2020)** | K-4496CL | | 254mm | 290mm | SAE |
| | | Detroit DD13 (2021+)** | | | 285mm | | |
| | | Detroit DD15 | | | | | |
| | | Cummins X15 | K-4494CL (K-4573CLW*) | 254mm | 260mm | | |
| | | Cummins X12 | | | | | |
| | | Cummins ISX12N (CNG) | K-4512CL | | | | |
| | International Motors | Cummins X15 | K-4488CL (K-4573CLW*) | | 254mm | 260mm | ISO |
| | | International A26 | | | | | |
| | Kenworth Peterbilt | PACCAR MX11 (thru 2020)** | K-4488CL (K-4573CLW*) | K-4488CL-PAC | 254mm | 260mm | ISO |
| | | PACCAR MX13 (thru 2020)** | | | | | |
| | | Cummins X15 | | | | | |
| | | Cummins ISX12N (CNG) | K-4512CL | K-4512CL-PAC | | SAE | |
| | | PACCAR MX11 (2021+)** | K-4514CL | K-4514CL-PAC | 285mm | 290mm | ISO |
| PACCAR MX13 (2021+)** | | | | | | | |
| Volvo | Cummins X15 | K-4494CL (K-4573CLW*) | | 254mm | 260mm | SAE | |
| | Cummins ISX12N (CNG) | | | | | | K-4512CL |
| All OEMs | Cummins X15N (CNG) | K-4638CL | K-4638CL-PAC | 285mm | 290mm | ISO | |
| EHD-xxF112C-V PHDP-xxF112C | International Motors | Cummins L9 | K-4677CL | | 254mm | 260mm | SAE |
| | Kenworth Peterbilt | PACCAR MX11 | K-4676CL | K-4676CL-PAC | 285mm | 290mm | ISO |
| | | PACCAR MX13 | | | | | |
| | | PACCAR PX9 | K-4677CL | K-4677CL-PAC | 254mm | 260mm | SAE |
| Cummins L9 | | | | | | | |

*Clutch kit K-4573CLW is supplied directly from Eaton Cummins and only to be used on clutch claims when directed by an Eaton Cummins representative. Kit does not include Release Bearing, Input Shaft Repair Kit or Pilot Bearing.

** See **Note** under individual Clutch Kit Part Number below for specific obsolescence / conversion date.

Note: Release bearing kits K-4692W (A-10004340 - ISO) and K-4693W (A-100046341 - SAE) are supplied directly from Eaton Cummins. Use one release bearing based on OEM and engine when installing clutch kit K-4573CW. Refer to Input Shaft Repair Kit and Pilot Bearing section, order appropriate kit/part (customer pay) when installing clutch kit K-4573CLW.



CAUTION: Transmission and clutch components are transmission model, vehicle OEM and Engine Make/model specific. Failure to replace or install correct Clutch components and service parts will result in non-warrantable engine and/or transmission component damage.

K-4379 (ISO / Standard Dampener with 260mm Flywheel Bore Engines)

- PACCAR - Cummins Engines
- International Motors A26 Engines
- International Motors - Cummins Engines
- PACCAR MX Engines

Note: K-4379 Obsoleted 01/16/2023. Use K-4488CL or K-4488CL-PAC.

| | Description | P/N | QTY |
|---|---|------------------------------|-----|
| 1 | Driven Disc Assembly and Clutch Cover (NSS) | 105511-1 (Standard Dampener) | 1 |
| 2 | Release Bearing Assembly | 125969 | 1 |
| 3 | Input Shaft Repair Kit | K-4362 | 1 |

K-4488CL / K-4488CL-PAC (ISO / Soft Rate Dampener with 260mm Flywheel Bore Engines)

Can be used to replace K-4379

- PACCAR - Cummins Engines
- International Motors A26 Engines
- International Motors - Cummins Engines
- PACCAR MX Engines

Note: Only PACCAR MX 11 / MX 13 engines built prior to July 1, 2021.

| | Description | P/N | QTY |
|---|---|-------------------------------|-----|
| 1 | Driven Disc Assembly and Clutch Cover (NSS) | 105511-5 (Soft Rate Dampener) | 1 |
| 2 | Release Bearing Assembly | 125969 A-10004340 | 1 |
| 3 | Input Shaft Repair Kit | K-4569 | 1 |

K-4494CL (SAE / Soft Rate Dampener with 260mm Flywheel Bore Opening Engines)

- Freightliner - Cummins Engines
- Western Star - Cummins Engines
- Volvo - Cummins engine

| | Description | P/N | QTY |
|---|---|-------------------------------|-----|
| 1 | Driven Disc Assembly and Clutch Cover (NSS) | 105511-5 (Soft Rate Dampener) | 1 |
| 2 | Release Bearing Assembly | 125968 A-10004341 | 1 |
| 3 | Input Shaft Repair Kit | K-4569 | 1 |

K-4496CL (SAE / Soft Rate Dampener with 290mm Flywheel Bore Opening Engines)

- Freightliner - Detroit Diesel Engines
- Western Star - Detroit Diesel Engines

Note: Covers all DD engines (DD13 / DD15 built October 1, 2019 to present).

| | Description | P/N | QTY |
|---|---|-------------------------------|-----|
| 1 | Driven Disc Assembly and Clutch Cover (NSS) | 105519-5 (Soft Rate Dampener) | 1 |
| 2 | Release Bearing Assembly | 125968 A-10004341 | 1 |
| 3 | Input Shaft Repair Kit | K-4694 | 1 |

K-4513CL (SAE / Soft Rate Dampener with 290mm Flywheel Bore Opening Engines)

- Freightliner - Detroit Diesel Engines
- Western Star - Detroit Diesel Engines

Note: K-4513CL obsoleted 01/16/2023. Use K-4496CL.

| | Description | P/N | QTY |
|---|---|--------------------------------|-----|
| 1 | Driven Disc Assembly and Clutch Cover (NSS) | 105521-20 (Soft Rate Dampener) | 1 |
| 2 | Release Bearing Assembly | 125968 | 1 |
| 3 | Input Shaft Repair Kit | K-4485 | 1 |

**K-4514CL / K-4514CL-PAC
(ISO / PACCAR Only / Soft Rate Dampener with
290mm Flywheel Bore Opening Engines)**

- PACCAR MX 11 / MX 13 Engines with 290mm Flywheel Bore Opening
- Cummins X15N (Natural Gas)

Note: Only PACCAR MX 11 / MX 13 engines built after July 1, 2021 to present.

| | Description | P/N | QTY |
|---|---|-----------------------------------|-----|
| 1 | Driven Disc Assembly and Clutch Cover (NSS) | 105521-20 (Soft Rate Dampener) | 1 |
| 2 | Release Bearing Assembly | 125969 A-10004340 | 1 |
| 3 | Input Shaft Repair Kit | K-4569 | 1 |

**K-4512CL / K-4512CL-PAC
(SAE / Soft Rate Dampener with 260mm
Flywheel Bore Opening Engines)**

- Cummins ISX 12N (Natural Gas)

Note: K-4512CL-PAC obsoleted 01/16/2023. Use K-4512CL.

| | Description | P/N | QTY |
|---|---|----------------------------------|-----|
| 1 | Driven Disc Assembly and Clutch Cover (NSS) | 105511-7 (Soft Rate Dampener) | 1 |
| 2 | Release Bearing Assembly | 125968 A-10004341 | 1 |
| 3 | Input Shaft Repair Kit | K-4569 | 1 |

**K-4676CL / K-4676CL-PAC (ISO HD Vocational
and TX-12 Pro) (ISO / Low Torque Extreme Duty
Dampener with 290mm Flywheel Bore Opening
Engines)**

- PACCAR MX 11 / MX 13 Engines with 290mm Flywheel Bore Opening
- Endurant HD Vocational / TX12 Pro Only

Note: Endurant HD Vocational / TX12 Pro Series Only

| | Description | P/N | QTY |
|---|---|---|-----|
| 1 | Driven Disc Assembly and Clutch Cover (NSS) | 105561-CL-60 (Low Torque Extreme Duty) | 1 |
| 2 | Release Bearing Assembly | A-10004340 | 1 |
| 3 | Input Shaft Repair Kit | K-4569 | 1 |

K-4677CL - K-4677CL-PAC (SAE HD Vocational and Non-Vocational) (SAE / Low Torque Extreme Duty Dampener with 260mm Flywheel Bore Opening Engines)

- PX-9 PACCAR / L-9 Cummins Engines

| | Description | P/N | QTY |
|---|---|---------------------------------------|-----|
| 1 | Driven Disc Assembly and Clutch Cover (NSS) | 105551-CL-7 (Low Torque Extreme Duty) | 1 |
| 2 | Release Bearing Assembly | A-10004341 | 1 |
| 3 | Input Shaft Repair Kit | K-4569 | 1 |

K-4638CL / K-4638CL-PAC (ISO / HD-N Extreme duty up to 2050 lb-ft. with 290mm Flywheel Bore Engines)

- Cummins X15N (Natural Gas)

| | Description | P/N | QTY |
|---|---|-----------------------------------|-----|
| 1 | Driven Disc Assembly and Clutch Cover (NSS) | 105561-CL-60 (Soft Rate Dampener) | 1 |
| 2 | Release Bearing Assembly | A-10004340 | 1 |

Note: Input Shaft Repair Kit K-4569 must be ordered separately.

Input Shaft Repair Kit

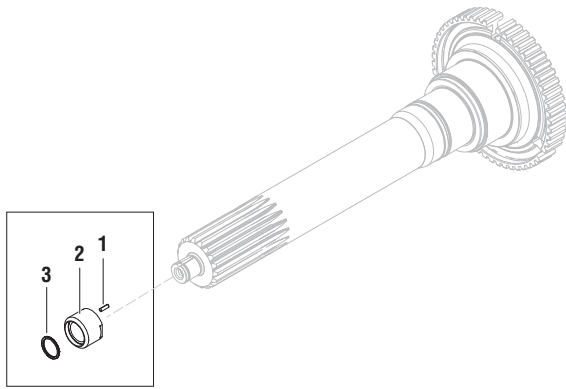

Note: Kit includes items: 1, 2 and 3. Pilot Bearings were removed effective 03/18/2024 and are purchased separately.

Input Shaft Repair Kit Part Number Identification

Use the diagram below to identify wear sleeve installed on your Input Shaft or table based on your OEM and Engine to determine Input Shaft Repair Kit.

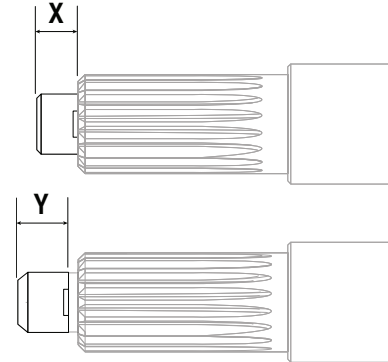

| | Measurement | Kit Part Number |
|---|--|-----------------|
| X | 20.50 - 20.80 mm (0.807 - 0.819 in) | K-4569 |
| Y | 24.82 - 25.12 mm (0.977 - 0.989 in) | K-4694 |

| OEM | Engine | Kit Part Number |
|------------------------------|-------------------|-----------------|
| Freightliner Western Star | Detriot Diesel | K-4694 |
| | Cummins | K-4569 |
| Kenworth Peterbilt | PACCAR MX | K-4569 |
| | Cummins | |
| International Motors | International A26 | K-4569 |
| | Cummins | |
| Volvo | Cummins | K-4569 |

K-4569**Note:** Replaces K-4362 (obsoleted 03/18/2024).

- Freightliner - Cummins Engines
- Kenworth - Cummins Engines
- International Motors - A26 Engines
- International Motors - Cummins Engines
- Peterbilt - Cummins Engines
- Volvo - Cummins Engines
- Western Star - Cummins Engines
- PACCAR - MX Engines

| | Description | Part Number | QTY |
|---|---------------------------------|-------------|-----|
| 1 | Wear Sleeve Alignment Pin (NSS) | 10001190 | 1 |
| 2 | Pilot Bearing Wear Sleeve (NSS) | 10001335 | 1 |
| 3 | Spiral Snap Ring (NSS) | 10001444 | 1 |

K-4694**Note:** Replaces K-4485 (obsoleted 03/18/2024).

- Freightliner - Detroit Diesel Engines
- Western Star - Detroit Diesel Engines

| | Description | Part Number | QTY |
|---|---------------------------------|-------------|-----|
| 1 | Wear Sleeve Alignment Pin (NSS) | 10001190 | 1 |
| 2 | Pilot Bearing Wear Sleeve (NSS) | 10003876 | 1 |
| 3 | Spiral Snap Ring (NSS) | 10001444 | 1 |

Pilot Bearings

Use the table below to identify the Pilot Bearing for your engine.

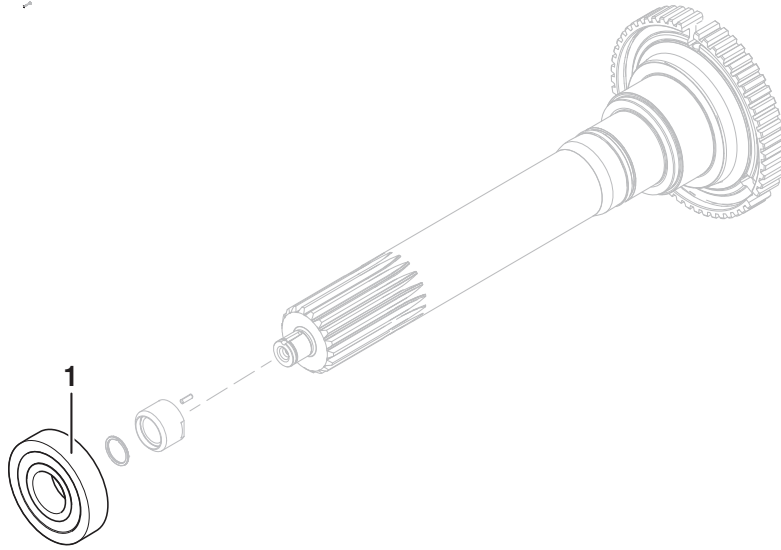

| | Engine | Pilot Bearing Series | Part Number |
|--------------------------|------------------------------|----------------------|-------------|
| 1 | PACCAR MX11 | 6206 | 5566516* |
| | PACCAR MX13 | | |
| | Cummins ISX 12N / L-9 / PX-9 | 6306 | 5566517 |
| | Cummins X12 | | |
| | Cummins X15 | | |
| | Detroit DD13 | | |
| | Detroit DD15 | | |
| | Detroit DD16 | | |
| International Motors A26 | 5206 | 5566518* | |

Note: *This Pilot Bearing has been obsoleted and is no longer available for purchase through Eaton or Eaton Cummins Joint Venture parts as of 08/06/2025.

Input Shaft Kit Part Number Identification

Use the diagram below to identify the input shaft installed in the transmission and compare to vehicle OEM - Engine.

- Locate the part number on the end of the input shaft as shown in Diagram a. Compare input shaft part number and OEM - Engine to determine Kit Part Number in table below, primary identification.
- If part number is illegible - Measure the input shaft as shown in Diagram b. Compare input shaft measurement (X) and OEM Engine to determine Kit Part Number in table below, secondary identification.

NOTICE: For secondary identification, input shaft and cover must be fully assembled in Clutch Housing.

- OEM - Engine



CAUTION: Install the correct input shaft based on the current input shaft installed in the transmission and OEM - Engine. Failure to install the correct input shaft results in non-warrantable engine and/or transmission component damage.

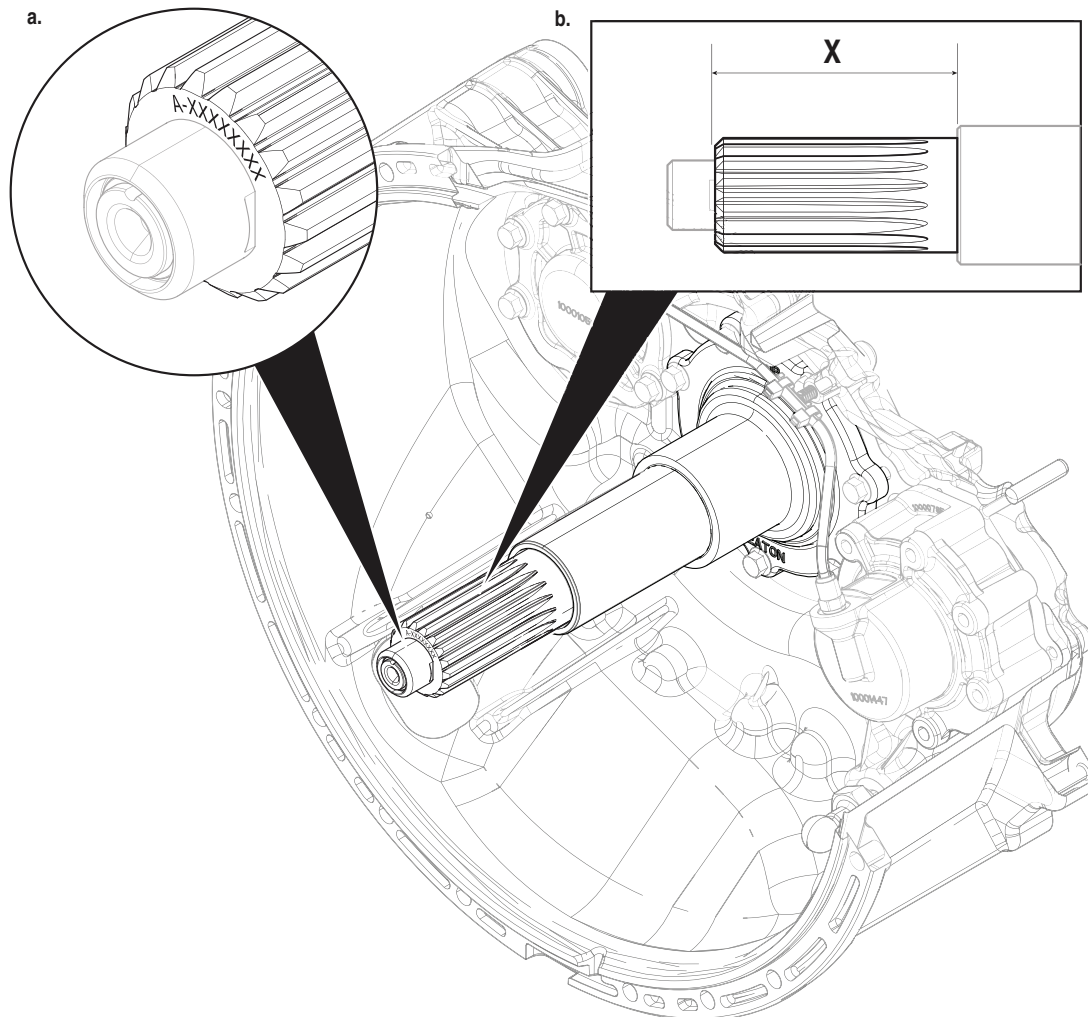

| a. | b. | c. | | Kit Part Number |
|------------------------------------|--|----------------------|-------------------------------|---------------------|
| Primary Identification Part Number | Secondary Identification Measurement (X) | OEM | Engine | |
| A-10001529 (ISO) | 90.50 - 92.50 mm (3.563 - 3.642 in) | International Motors | A26, International | K-4659* K-4360** |
| | | International Motors | Cummins (Diesel) | |
| | | Kenworth | Cummins (Diesel) | |
| | | Peterbilt | Cummins (Diesel) | |
| | | Kenworth | MX-11, MX-13 PACCAR | |
| | | Peterbilt | MX-11, MX-13 PACCAR | |
| | | All OEMs | X15N Cummins (Natural Gas) | |
| A-10003441 (SAE) | 79.50 - 81.50 mm (3.130 - 3.209 in) | Freightliner | L9, X12, X15 Cummins (Diesel) | K-4660* K-4361** |
| | | Kenworth | PX-9 PACCAR | |
| | | Peterbilt | PX-9 PACCAR | |
| | | Volvo | Cummins (Diesel) | |
| | | Western Star | L9, X12, X15 Cummins (Diesel) | |
| | | All OEMs | ISX12N Cummins (Natural Gas) | |
| | | All OEMs | L9 Cummins | |
| A-10003878 | 82.00 - 84.00 mm (3.228 - 3.307 in) | Freightliner | Detroit Diesel | K-4661* K-4363** |
| | | Western Star | Detroit Diesel | |

*Hard lock bearing design

**Non-hard lock bearing design

Input Shaft Kits

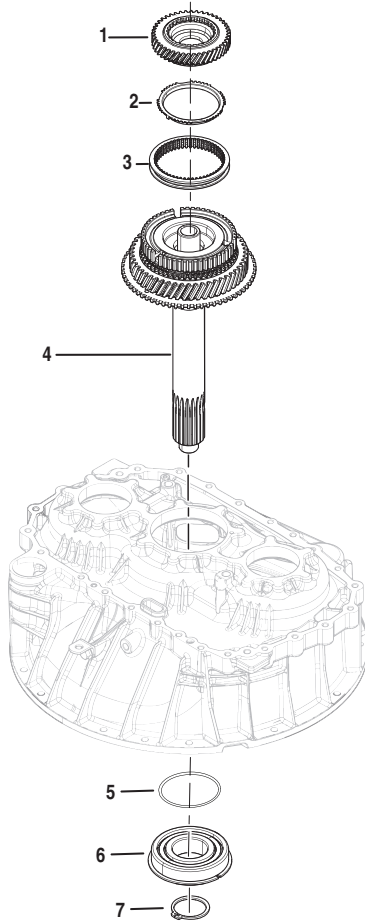

K-4360 (ISO) - Superseded



CAUTION: Refer to Input Shaft Kit Part Number Identification table to determine Input Shaft Kit part number. Failure to install the correct input shaft results in non-warrantable engine and/or transmission component damage.

Note: HD production Input Shaft Bearing 10004584 changed to hard lock bearing design. K-4360 superseded by K-4659 in NAFTA 06/03/2023.

| | Description | Part Number | QTY |
|-----|-------------------------------------|-------------|-----|
| 1 | Primary Drive Gear | S-3206 | 1 |
| 2 | Rail B Synchronizer Ring | 10002550 | 1 |
| 3 | Rail B Synchronizer Sliding Sleeve | 10001942 | 1 |
| 4 | Input Shaft Assembly (NSS) | S-3205 | 1 |
| 5 | Input Shaft Bearing O-Ring | 10003862 | 1 |
| 6 | Input Shaft Bearing | 10000552 | 1 |
| 7 | Input Shaft Snap Ring | 10000624 | 1 |
| Kit | Rail B Synchronizer Small Parts Kit | K-4388 | 1 |

Note: The Main Shaft End-Play procedure is required if the Input Shaft is replaced. One of three Main Shaft Selective Washers are required to adjust end-play, Part Numbers: 10000555, 10001759, 10001760.

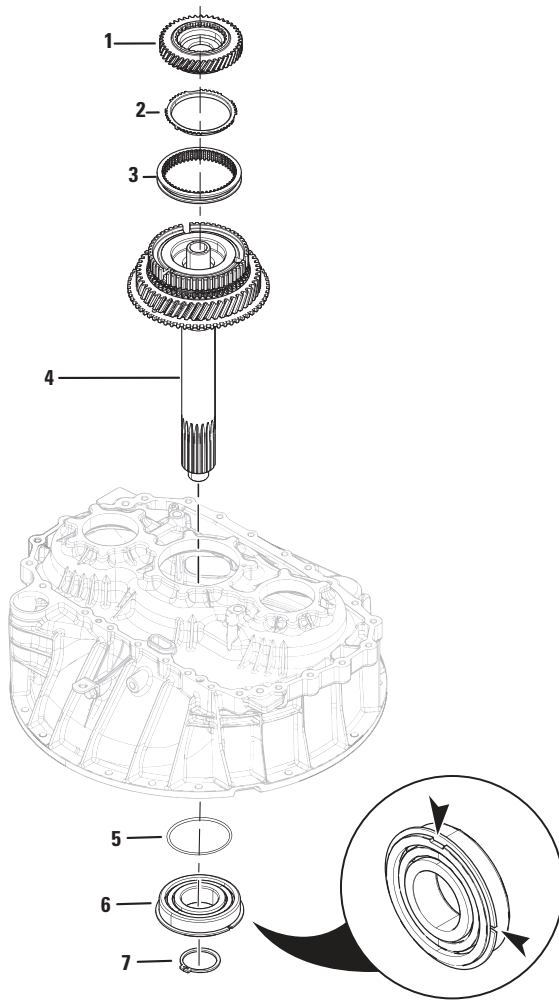

K-4659 (ISO Hard Lock Bearing Design)



CAUTION: Refer to Input Shaft Kit Part Number Identification table to determine Input Shaft Kit part number. Failure to install the correct input shaft results in non-warrantable engine and/or transmission component damage.

NOTICE: Input Shaft Bearing 10004584 (Hard Lock Bearing Design) required Input Shaft Cover Kit K-4657 (Hard Lock Bearing Design).

| | Description | Part Number | QTY |
|-----|-------------------------------------|-------------|-----|
| 1 | Primary Drive Gear | S-3206 | 1 |
| 2 | Rail B Synchronizer Ring | 10002550 | 1 |
| 3 | Rail B Synchronizer Sliding Sleeve | 10001942 | 1 |
| 4 | Input Shaft Assembly (NSS) | S-3205 | 1 |
| 5 | Input Shaft Bearing O-Ring | 10003862 | 1 |
| 6 | Input Shaft Bearing | 10004584 | 1 |
| 7 | Input Shaft Snap Ring | 10000624 | 1 |
| Kit | Rail B Synchronizer Small Parts Kit | K-4388 | 1 |

Note: The Main Shaft End-Play procedure is required if the Input Shaft is replaced. One of three Main Shaft Selective Washers are required to adjust end-play, Part Numbers: 10000555, 10001759, 10001760.

Note: Reference input shaft bearing installation procedure for bearing orientation when pressing in 10004584 input shaft bearing.

K-4361 (SAE) - Superseded



CAUTION: Refer to Input Shaft Kit Part Number Identification table to determine Input Shaft Kit part number. Failure to install the correct input shaft results in non-warrantable engine and/or transmission component damage.

Note: HD production changed to 10004584 Input Shaft Bearing early July 2023. K-4361 superseded by K-4660 in NAFTA 06/03/2023.

| | Description | Part Number | QTY |
|-----|-------------------------------------|-------------|-----|
| 1 | Primary Drive Gear | S-3206 | 1 |
| 2 | Rail B Synchronizer Ring | 10002550 | 1 |
| 3 | Rail B Synchronizer Sliding Sleeve | 10001942 | 1 |
| 4 | Input Shaft Assembly (NSS) | S-3207 | 1 |
| 5 | Input Shaft Bearing O-Ring | 10003862 | 1 |
| 6 | Input Shaft Bearing | 10000552 | 1 |
| 7 | Input Shaft Snap Ring | 10000624 | 1 |
| Kit | Rail B Synchronizer Small Parts Kit | K-4388 | 1 |

Note: The Main Shaft End-Play procedure is required if the Input Shaft is replaced. One of three Main Shaft Selective Washers are required to adjust end-play, Part Numbers: 10000555, 10001759, 10001760.

K-4660 (SAE Hard Lock Bearing Design)



CAUTION: Refer to Input Shaft Kit Part Number Identification table to determine Input Shaft Kit part number. Failure to install the correct input shaft results in non-warrantable engine and/or transmission component damage.

NOTICE: Input Shaft Bearing 10004584 (Hard Lock Bearing Design) requires Input Shaft Cover Kit K-4657 (Hard Lock Bearing Design).

| | Description | Part Number | QTY |
|-----|-------------------------------------|-------------|-----|
| 1 | Primary Drive Gear | S-3206 | 1 |
| 2 | Rail B Synchronizer Ring | 10002550 | 1 |
| 3 | Rail B Synchronizer Sliding Sleeve | 10001942 | 1 |
| 4 | Input Shaft Assembly (NSS) | S-3207 | 1 |
| 5 | Input Shaft Bearing O-Ring | 10003862 | 1 |
| 6 | Input Shaft Bearing | 10004584 | 1 |
| 7 | Input Shaft Snap Ring | 10000624 | 1 |
| Kit | Rail B Synchronizer Small Parts Kit | K-4388 | 1 |

Note: The Main Shaft End-Play procedure is required if the Input Shaft is replaced. One of three Main Shaft Selective Washers are required to adjust end-play, Part Numbers: 10000555, 10001759, 10001760.

Note: Reference input shaft bearing installation procedure for bearing orientation when pressing in 10004584 input shaft bearing.

K-4363 (Detroit Only) - Superseded

CAUTION: Refer to Input Shaft Kit Part Number Identification table to determine Input Shaft Kit part number. Failure to install the correct input shaft results in non-warrantable engine and/or transmission component damage.

Note: HD production changed to 10004584 Input Shaft Bearing early July 2023. K-4363 superseded by K-4661 in NAFTA 06/03/2023.

| | Description | Part Number | QTY |
|-----|-------------------------------------|-------------|-----|
| 1 | Primary Drive Gear | S-3206 | 1 |
| 2 | Rail B Synchronizer Ring | 10002550 | 1 |
| 3 | Rail B Synchronizer Sliding Sleeve | 10001942 | 1 |
| 4 | Input Shaft Assembly (NSS) | S-3199 | 1 |
| 5 | Input Shaft Bearing O-Ring | 10003862 | 1 |
| 6 | Input Shaft Bearing | 10000552 | 1 |
| 7 | Input Shaft Snap Ring | 10000624 | 1 |
| Kit | Rail B Synchronizer Small Parts Kit | K-4388 | 1 |

Note: The Main Shaft End-Play procedure is required if the Input Shaft is replaced. One of three Main Shaft Selective Washers are required to adjust end-play, Part Numbers: 10000555, 10001759, 10001760.

K-4661 (Detroit Only Hard Lock Bearing Design)

CAUTION: Refer to Input Shaft Kit Part Number Identification table to determine Input Shaft Kit part number. Failure to install the correct input shaft results in non-warrantable engine and/or transmission component damage.

NOTICE: Input Shaft Bearing 10004584 (Hard Lock Bearing Design) requires Input Shaft Cover Kit K-4657 (Hard Lock Bearing Design).

| | Description | Part Number | QTY |
|-----|-------------------------------------|-------------|-----|
| 1 | Primary Drive Gear | S-3206 | 1 |
| 2 | Rail B Synchronizer Ring | 10002550 | 1 |
| 3 | Rail B Synchronizer Sliding Sleeve | 10001942 | 1 |
| 4 | Input Shaft Assembly (NSS) | S-3199 | 1 |
| 5 | Input Shaft Bearing O-Ring | 10003862 | 1 |
| 6 | Input Shaft Bearing | 10004584 | 1 |
| 7 | Input Shaft Snap Ring | 10000624 | 1 |
| Kit | Rail B Synchronizer Small Parts Kit | K-4388 | 1 |

Note: The Main Shaft End-Play procedure is required if the Input Shaft is replaced. One of three Main Shaft Selective Washers are required to adjust end-play, Part Numbers: 10000555, 10001759, 10001760.

Note: Reference input shaft bearing installation procedure for bearing orientation when pressing in 10004584 input shaft bearing.

Transmission Service Unit, Reman or Complete, Part Number Identification

Use the diagram below to identify the Input Shaft installed in your transmission. Verify Input Shaft and OEM - Engine to determine the correct transmission service unit part number.

- Locate the part number on the end of the Input Shaft as shown in Diagram a. Compare input shaft part number to Service Unit Part Number in table below, primary identification.

Note: The additional part number in the primary identification is the assembly part number used in the Bill of Material (BOM).

- If part number is illegible - Measure input shaft as shown in Diagram b. Compare input shaft measurement (X) to Service Unit Part Number in table below, secondary identification.

NOTICE: For secondary identification, input shaft and cover must be fully assembled in Clutch Housing.

- OEM - Engine



CAUTION: Install the correct service unit based on the current input shaft installed in the transmission and OEM - Engine. Failure to install the correct service unit results in non-warrantable engine and/or transmission component damage.

Note: Service Unit part numbers support both 11-Speed and 12-Speed transmissions.

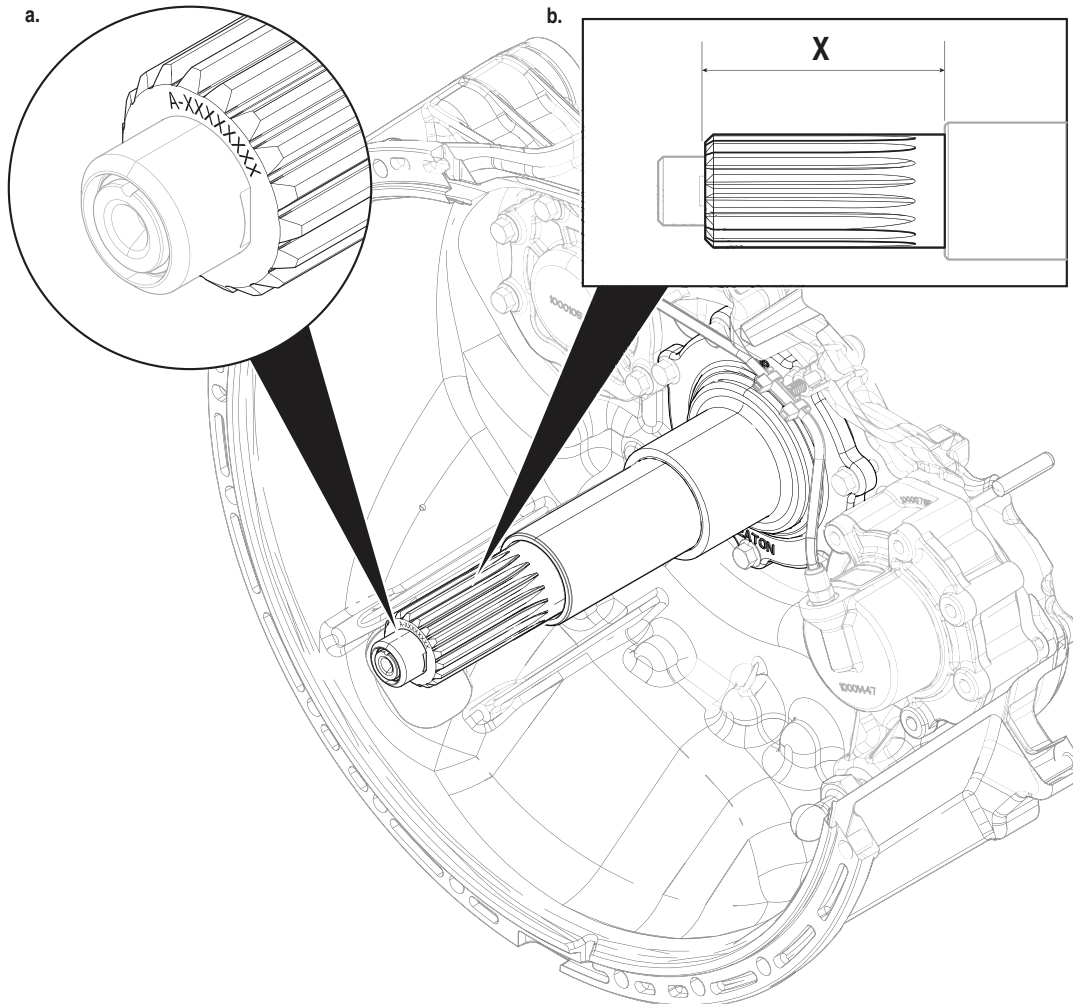

Single PTO

| a. | b. | c. | | | |
|---|--|----------------------|-------------------------------|--|--|
| Primary Identification Part Number (Assembly Part Number) | Secondary Identification Measurement (X) | OEM | Engine | Reman Service Unit Part Number (Single PTO) w/o TCM, MTM | Complete Service Unit Part Number (Single PTO) w/o TCM |
| A-10001529 ISO (10001336) | 90.50 - 92.50 mm (3.563 - 3.642 in) | International Motors | A26, International | TN-H04-12R* [TN-H04-12R* superseded TN-H04-75RR* as of 04/01/2025] | TA-H04-12X |
| | | International Motors | Cummins (Diesel) | | |
| | | Kenworth | Cummins (Diesel) | | |
| | | Peterbilt | Cummins (Diesel) | | |
| | | Kenworth | MX-11, MX-13 PACCAR | | |
| | | Peterbilt | MX-11, MX-13 PACCAR | | |
| | | All OEMs | X15N Cummins (Natural Gas) | | |
| A-10003441 SAE (10003440) | 79.50 - 81.50 mm (3.130 - 3.209 in) | Freightliner | L9, X12, X15 Cummins (Diesel) | TN-H04-31R | TA-H04-31X |
| | | Kenworth | PX-9 PACCAR | | |
| | | Peterbilt | PX-9 PACCAR | | |
| | | Volvo | Cummins (Diesel) | | |
| | | Western Star | L9, X12, X15 Cummins (Diesel) | | |
| | | All OEMs | ISX12N Cummins (Natural Gas) | | |
| | | All OEMs | L9 Cummins | | |
| A-10003878 (10003877) | 82.00 - 84.00 mm (3.228 - 3.307 in) | Freightliner | Detroit Diesel | TN-H04-34R | TA-H04-34X |
| | | Western Star | Detroit Deisel | | |



CAUTION: *Service units may be equipped with a Dual (4-Bolt) PTO Rear Housing. Do not install a 4-Bolt PTO. If a 4-Bolt PTO is installed, PTO and/or transmission component damage will occur. Reference **TAIB-1010**.

Dual PTO

Note: Endurant HD Vocational and TX-12 Pro Transmission replacement units are all Dual PTO units shown below.

| a. | b. | c. | | | |
|---|--|----------------------|-------------------------------|--|--|
| Primary Identification Part Number (Assembly Part Number) | Secondary Identification Measurement (X) | OEM | Engine | Reman Service Unit Part Number (Dual PTO) w/o TCM, MTM | Complete Service Unit Part Number (Dual PTO) w/o TCM |
| A-10001529 ISO (10001336) | 90.50 - 92.50 mm (3.563 - 3.642 in) | International Motors | A26, International | TN-H04-26R | TA-H04-26X |
| | | International Motors | Cummins (Diesel) | | |
| | | Kenworth | Cummins (Diesel) | | |
| | | Peterbilt | Cummins (Diesel) | | |
| | | Kenworth | MX-11, MX-13 PACCAR | | |
| | | Peterbilt | MX-11, MX-13 PACCAR | | |
| | | All OEMs | X15N Cummins (Natural Gas) | | |
| A-10003441 SAE (10003440) | 79.50 - 81.50 mm (3.130 - 3.209 in) | Freightliner | L9, X12, X15 Cummins (Diesel) | TN-H04-32R | TA-H04-32X |
| | | Kenworth | PX-9 PACCAR | | |
| | | Peterbilt | PX-9 PACCAR | | |
| | | Volvo | Cummins (Diesel) | | |
| | | Western Star | L9, X12, X15 Cummins (Diesel) | | |
| | | All OEMs | ISX12N Cummins (Natural Gas) | | |
| | | All OEMs | L9 Cummins | | |
| A-10003878 (10003877) | 82.00 - 84.00 mm (3.228 - 3.307 in) | Freightliner | Detroit Diesel | TN-H04-35R | TA-H04-35X |
| | | Western Star | Detroit Deisel | | |

Oil Level Inspection Procedure

Special Instructions

None

Special Tools

None

Component Identification

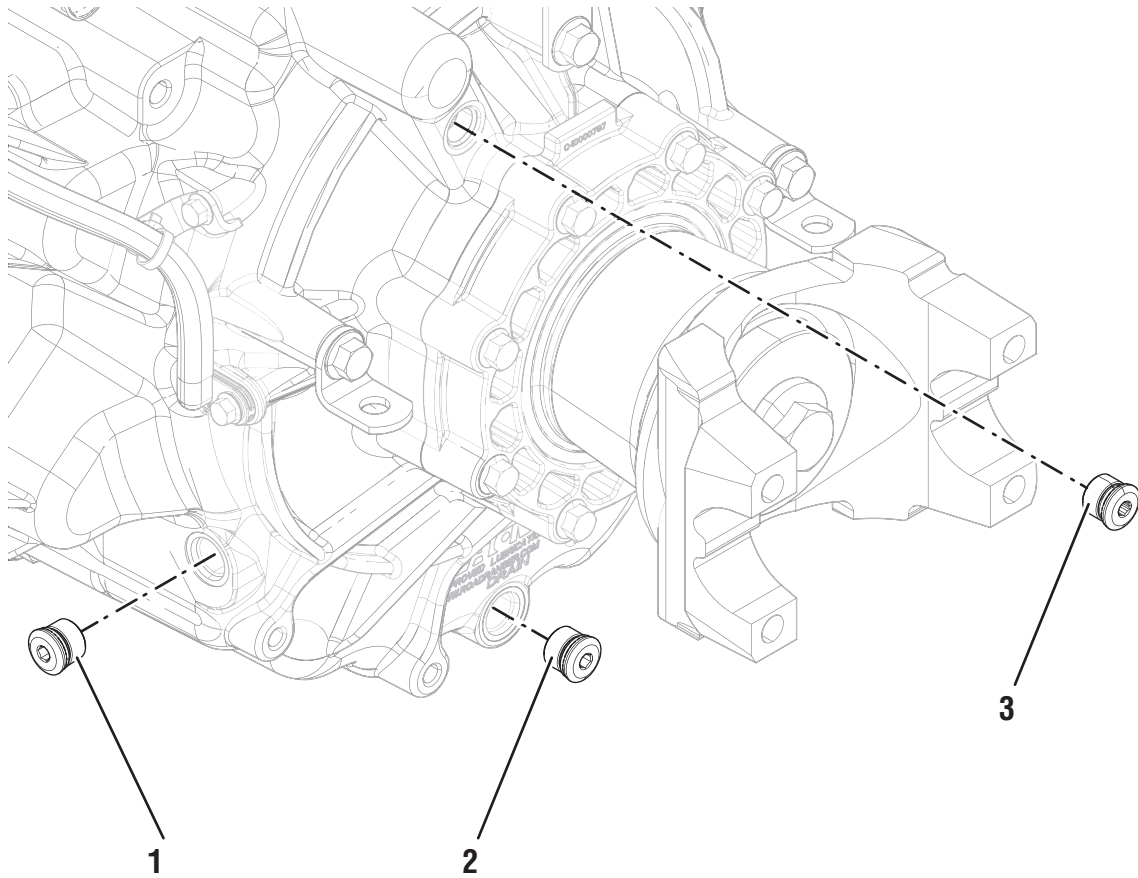

1. Oil Check Plug - 6 mm Hex
2. Oil Drain Plug - 6 mm Hex
3. Oil Fill Plug - 6 mm Hex

Oil Level Inspection

1. Park vehicle in a safe area on level ground.
2. Key off.
3. Set vehicle parking brake and chock wheels.

! **WARNING:** Apply parking brake and follow vehicle manufacturer parking instructions. Failure to follow these instructions may cause unintended vehicle movement resulting in major vehicle component damage, severe injury or death.

4. Locate the transmission Oil Check Plug on the left side of the rear housing.



5. Place a suitable container under the Oil Check Plug and remove the Oil Check Plug with a 6 mm hex key.
6. Oil level is correct when a small amount of oil runs out of the Oil Check Plug hole.
 - If oil level is not correct, go to Step 7.
 - If oil level is correct, go to Step 12.
7. Remove the Oil Fill Plug with a 6 mm hex key.

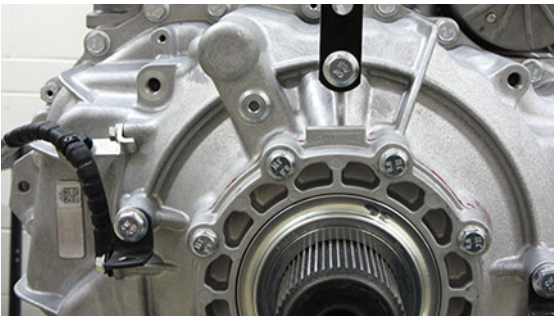

8. Place a suitable container under the Oil Check Plug and remove the Oil Check Plug with a 6 mm hex key.



9. Fill the transmission with PS-386 lube until a small amount of oil runs out of the Oil Check Plug hole.

Note: Perform the transmission fill procedure with transmission installed in vehicle to ensure proper transmission angle.

Note: Fill capacity is approximately 7.5-8.5 liters (16-18 pints) depending on the transmission angle.

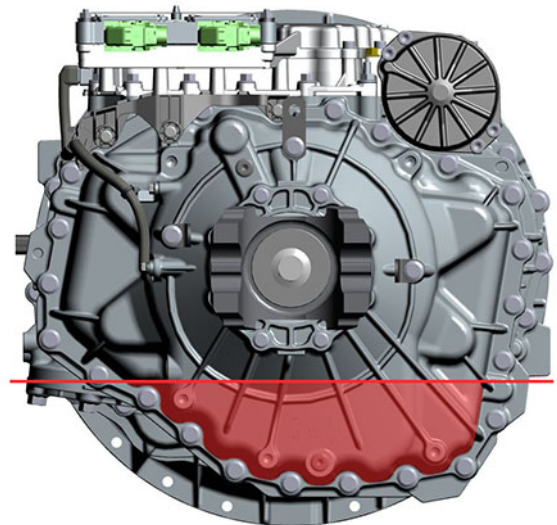
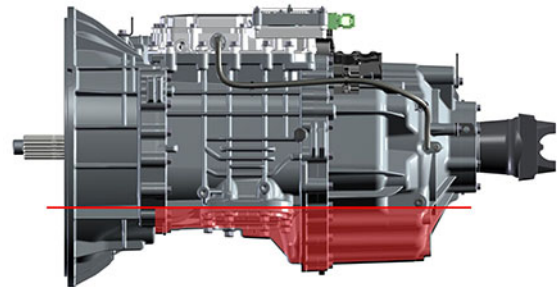

10. Inspect Oil Fill Plug and O-ring for damage. If damaged, replace the Oil Fill Plug; O-ring is serviced with plug.
11. Install the Oil Fill Plug and torque to 24.5-29.5 Nm (18-22 lb-ft).

NOTICE: Do not over-torque the Oil Fill Plug or transmission damage may occur.

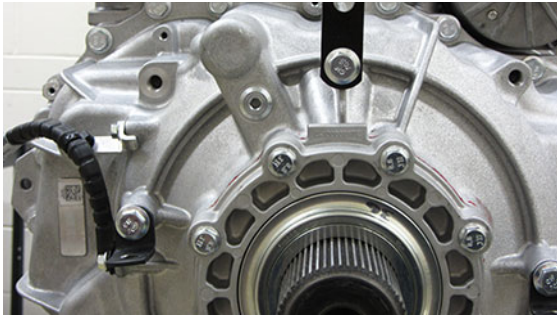

12. Inspect the Oil Check Plug and O-ring for damage. If damaged, replace the Oil Check Plug; O-ring is serviced with plug.
13. Install the Oil Check Plug and torque to 24.5–29.5 Nm (18–22 lb-ft).

NOTICE: Do not over-torque the Oil Check Plug or transmission damage may occur.

NOTICE: If PTO-equipped, start the engine and run for 1 to 2 minutes to fill the PTO with oil, key off and go to Step 5.

Oil Leak Inspection Process

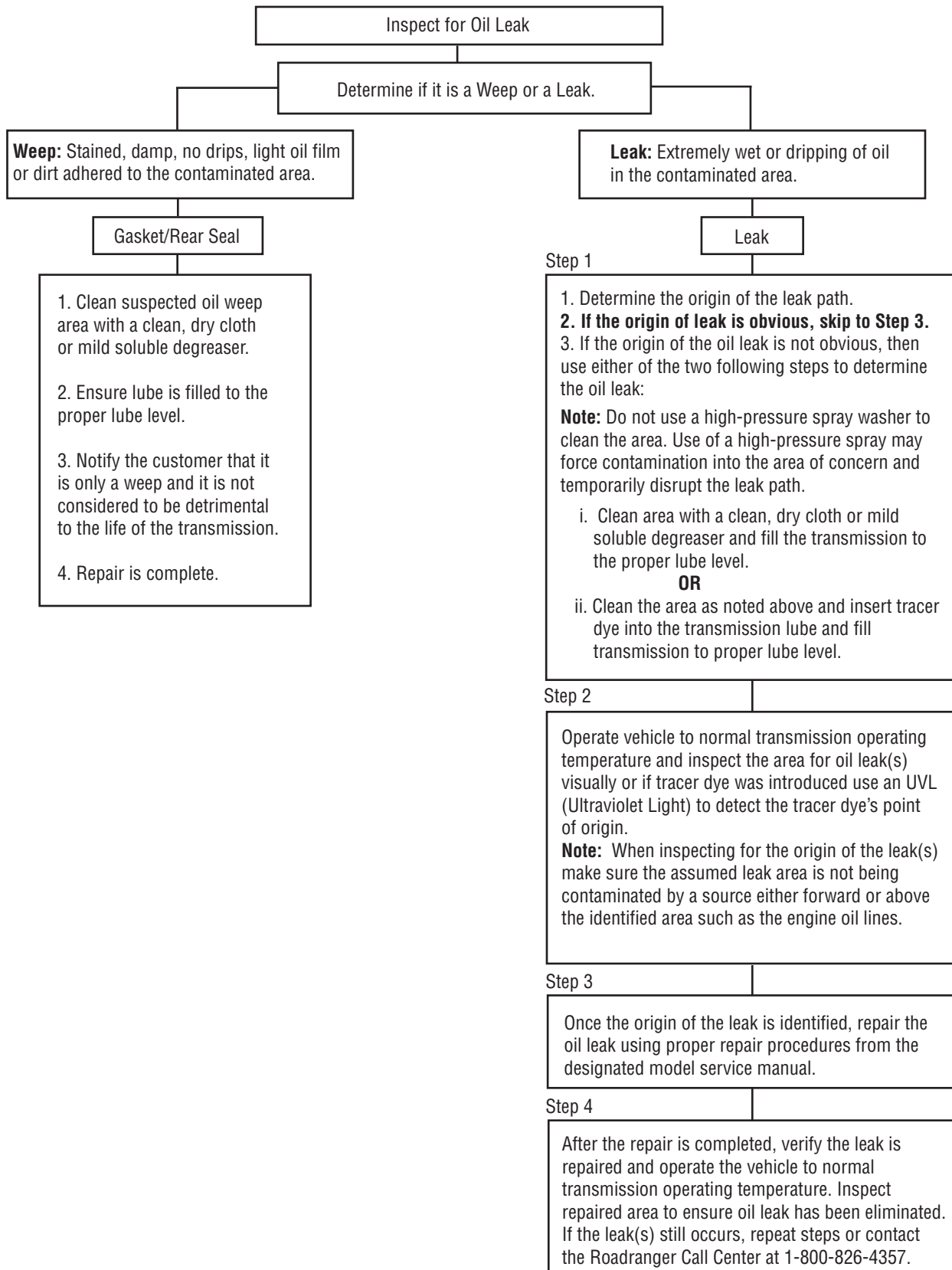

Lubrication Specifications

Lubricant, PS-386 HD Synthetic Transmission

Use only Eaton approved lubricant. For information, see TCMT0021 Eaton Lubrication Product Specification Manual.

NOTICE: Failure to use the approved lubricant will affect the transmission performance and the warranty coverage.

NOTICE: Additives and/or friction modifiers are not approved. Additives of any kind will affect the transmission performance and the warranty coverage.

For a list of Eaton approved lubricant suppliers, see TCMT0020 Eaton Approved Lubricant Suppliers Lubrication Guide.

Maintenance and Lubricant Change Intervals

Transmission inspections and lubricant change intervals are outlined below.

Use only Eaton approved lubricant. For information, see TCMT0021 Eaton Lubrication Product Specification Manual.

Vehicle Maintenance Recommendations

Transmission Air Supply

For optimal performance, the Endurant transmission requires a nominal air supply operating range between 99 psi (683 kPa) and 130 psi (896 kPa). Air supply outside this range can result in degraded or complete loss of transmission engagement and shift capabilities.

Air Quality

Clean dry air is required for the transmission system to shift properly.

The Endurant transmission air supply is required to meet or exceed ISO 8573-1:2010 7.3.4. The vehicle air system supplying the transmission shall use a high quality, commercially available oil coalescing air dryer. Air quality for solid contamination shall meet a minimum of ISO 8573 Class 7. Air quality for water contamination shall meet a minimum of ISO 8573-1 Class 3. Air quality for oil contamination shall meet a minimum of ISO 8573-1 Class 4.



CAUTION: Follow OEM guidelines for air dryer service intervals. Eaton Cummins Automated Transmission Technologies highly recommends an air dryer filter cartridge service interval of one (1) year or less. Failure to follow recommended service interval may result in contamination of the MTM and void warranty.

NOTICE: Air additives such as alcohol devices should not be permitted to enter the transmission air supply. Additives could cause damage to air system components, which could lead to degraded transmission performance.

Note: Reference Endurant HD Automated Transmission and Clutch System TRIG0950, Section 6: Pneumatic System Requirements for additional information.



CAUTION: Vehicle air quality is important for transmission system operation. Failure to follow the vehicle air system maintenance requirements may result in transmission component damage i.e., MTM contamination and voids transmission warranty. Refer to OEM and/or vehicle air system manufacturer guidelines for vehicle air and filter system maintenance.

Recommended Service Interval

North America (U.S., Canada and Mexico), Australia

| Endurant Model | On-Highway | Vocational & Line Haul over 214,400 | Stationary |
|----------------------------------|-----------------------------|--|------------------------|
| Endurant HD™ 11-Speed | 750,000 miles or 5 years | 250,000 miles or 3 years | N/A |
| Endurant HD™ 12-Speed | | | |
| Endurant HD™ Natural Gas | | | |
| Australia Line Haul / Heavy Haul | 500,000 miles or 5 years | | 2,500 hours or 3 years |

Note: Clutch assembly is maintenance free on Endurant HD.

Roadranger Specialty Tools

Note: Available for purchase at www.klineind.com.

Transmission Jack Adapter Plate (RR1067TR)

Clutch Installation Tool Kit (RR2000CL)

- Clutch Alignment Shaft (RR1087TR)
- Alignment Pins (x2) (RR1063TR-3)
- Stand-off Bolts (x4) (RR1063TR-4)

Basic Service Repair Kit (RR2010TR)

- Input Shaft Pilot Bearing Wear Sleeve Puller (RR1062TR)
- Wear Sleeve Installer (RR1061TR-1, 2)
- Inertia Brake Piston Seal Installer (RR1074TR-1, 2)
- Output Seal Driver (RR1001TR-8)
- Countershaft Pilot Tool, Lower (RR1071TR)
- Countershaft Pilot Tool, Upper (RR1072TR)
- Range Assembly Removal and Installation Tool (RR1065TR)

Electrical Diagnostic Kit

- Eaton Breakout Box with 74-Way Eaton Diagnostic Adapter (RR1029TR)
- 3-Way Eaton Diagnostic Adapter (RR1060TR)

Mechanical Diagnostic Kit (RR2011TR)

- MTM Alignment Tool (RR1086TR-1)
- Confirm-Neutral Gauge (RR1086TR-2)
- Rail B Engagement Tool (RR1088TR)

Input Shaft Cup (RR1085TR-6)

Front Bearing Capture Plate (RR1085TR-7)

Input Shaft Press (RR1085TR)

Note: The input shaft is required to be pressed in and out of the clutch housing. Input Shaft Press (RR1085TR) can be purchased if the clutch housing does not properly fit the available press.

Overhaul Tool Kit (RR2012TR)

- Input Shaft Bearing Removal and Installation Tool (RR1075TR)
- Countershaft Bearing Installer (RR1076TR)
- Main Shaft Bearing Installer (RR1077TR)
- Output Shaft Installer/Input Shaft Seal Driver (RR1070TR)
- Universal Driver Handle (OE8044-T0)
- Rear Housing Stand (RR1069TR)
- Input Shaft Stand (RR1073TR)

Note: The Input Shaft Stand may have already been purchased with Overhaul Tool Kit (RR2012TR)

Overhaul Tool Kit #2 (RR2013TR)

- Rear Alignment Pins (2) (RR1090TR)
- Output Bearing Install and Removal Tool (RR1089TR)
- Reaction Plate Install and removal Tool (RR1091TR)

Output Seal Driver Kit (RR1001TR)

- Output Seal Driver Handle (RR1001TR-2)

Note: The Output Seal Driver Kit (RR1001TR) may have already been purchased to support prior transmission models.

Input Bearing Driver (RR1049TR)

Note: The Input Bearing Driver (RR1049TR) may have already been purchased in Precision Level 1 Service Kit (RR2000TR).

Note: The input Bearing Driver (RR1049TR) only needs to be purchased and used if the clutch housing does not properly fit the available press.

20-Way Eaton Diagnostic Adapter (RR1030TR)

Bearing Lock Templates

Note: When printing templates, set printer properties at 100% and paper size to “Tabloid” (11” by 17”) to achieve proper sizing. Print from PDF version of document in landscape orientation.

Clutch Housing Bearing Templates

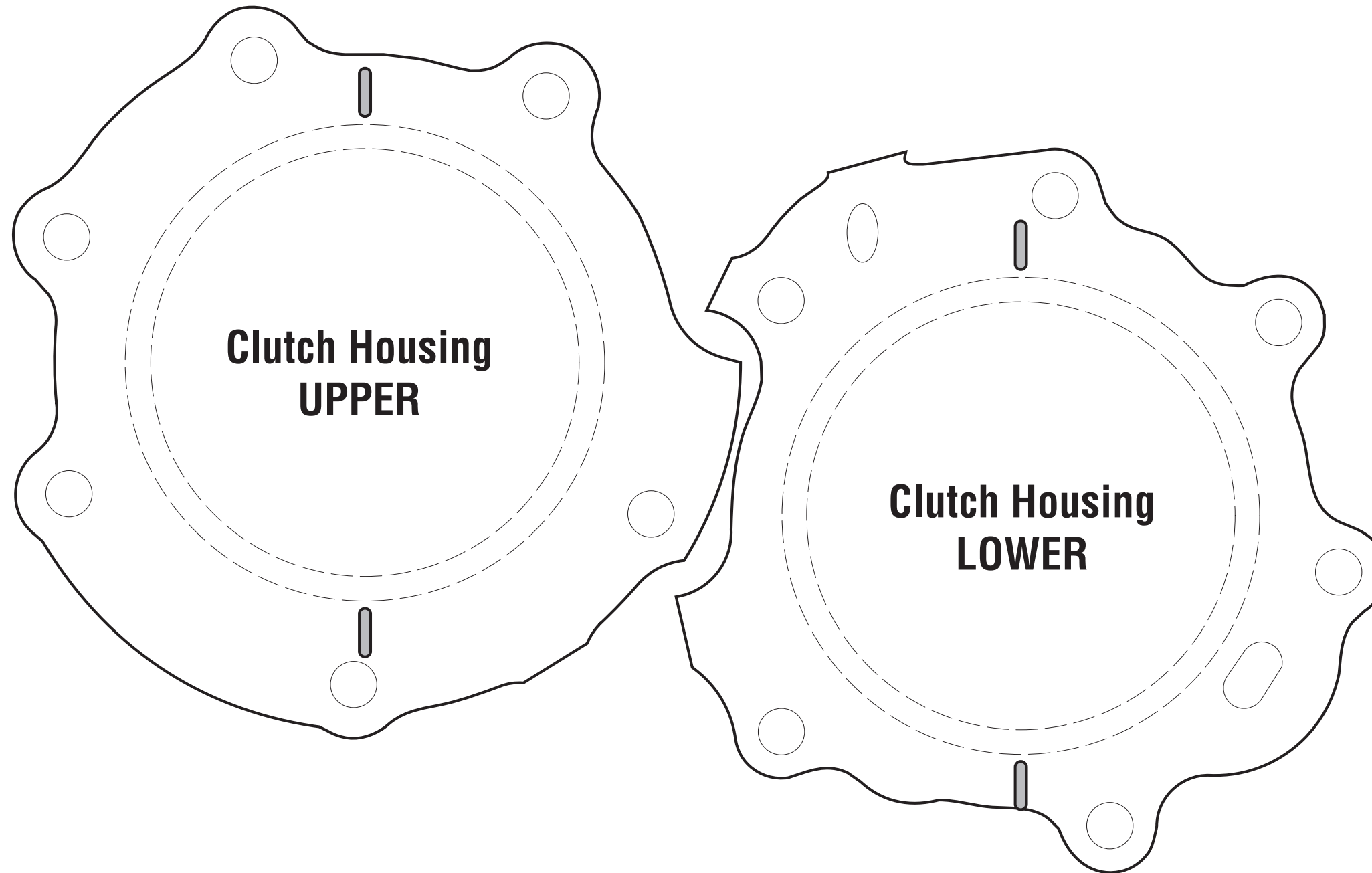

Front Input Bearing Template

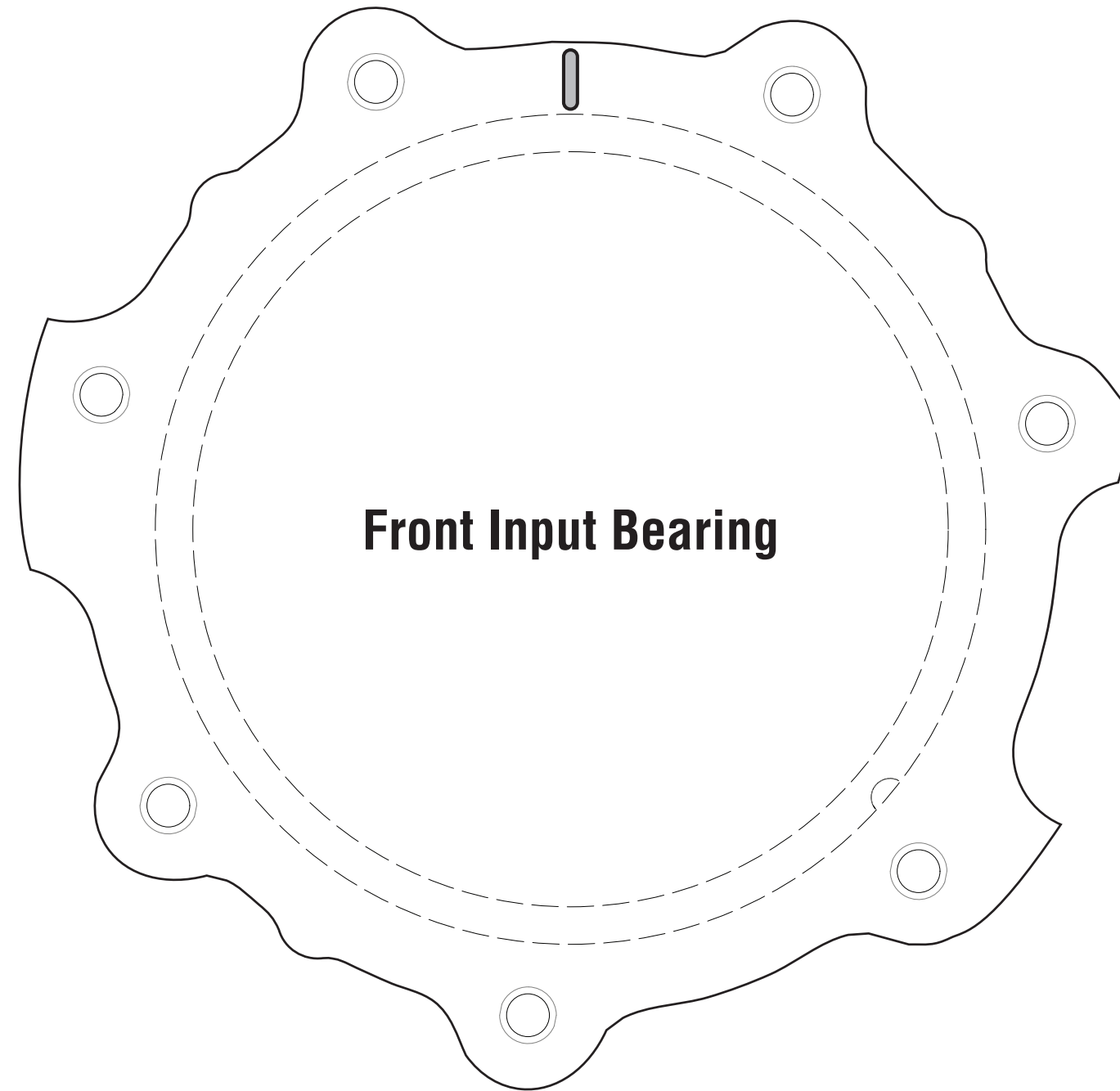

Main Housing Bearing Templates

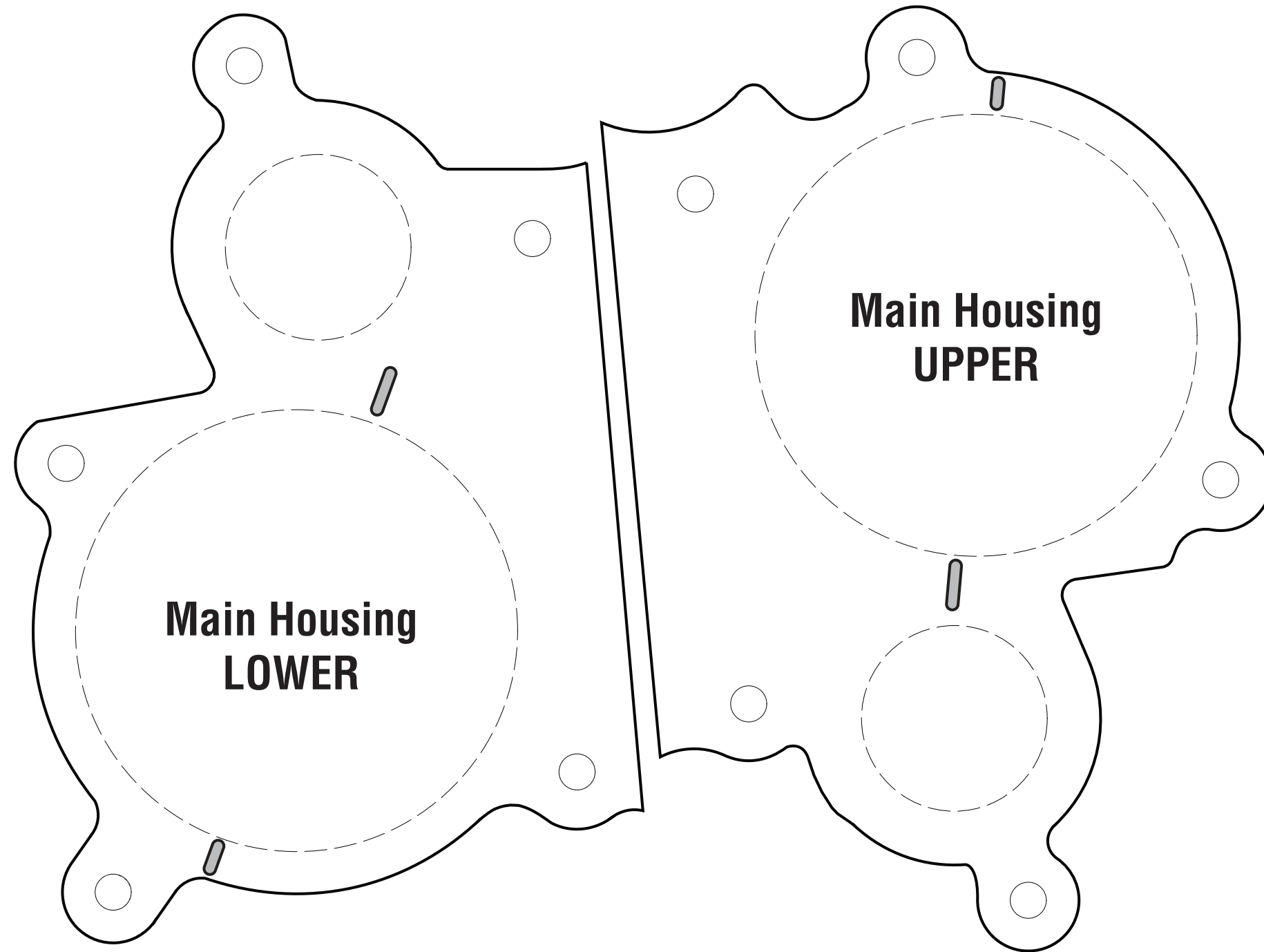

Inspection Precautions

Before reassembling the transmission, check each part carefully for abnormal wear, excessive wear or damage to determine if the part is suitable for reuse. When replacement is necessary, use only genuine Eaton Transmission parts to assure continued performance and extended life from your unit.

Since the cost of a new part is generally a small fraction of the total cost of downtime and labor, avoid reusing a questionable part. This could lead to additional repairs and expense soon after assembly. Consideration should also be given to the unit's history, mileage, application, etc. when determining the reuse or replacement of any transmission part.

Bearings

- Wash all bearings in clean solvent. Check balls, rollers and raceways for pitting, discoloration and spalled areas.
- Replace bearings that are pitted, discolored, spalled or damaged during disassembly.
- Lubricate bearings that are not pitted, discolored, or spalled and check for axial and radial clearances.
- Replace bearings with excessive clearances.
- Check bearing fit. Bearing inner races should be tight to shaft; outer races slightly tight to slightly loose in case bore. If the bearing spins freely in the bore the case should be replaced.

Bearing Covers

- Check covers for wear from thrust of adjacent bearing. Replace covers damaged from thrust of bearing outer race.
- Check cover bores for wear. Replace those worn or oversized.

Gears

- Check gear teeth for frosting and pitting. Frosting of gear teeth faces presents no threat of transmission failure. Often in continued operation of the unit, frosted gears “heal” and do not progress to the pitting stage. In most cases, gears with light to moderate pitted teeth have considerable gear life remaining and can be reused, but gears in the advanced stage of pitting should be replaced.

- Check for gears with clutching teeth abnormally worn, tapered, or reduced in length from clashing during shifting. Replace gears found in any of these conditions.
- Check axial clearance of gears.

All Parts

- Check all parts for cracks and breaks.
- Replace damaged parts.

Oil Seals

- Check oil seals. If sealing action of a lip has been destroyed, replace seal.

O-Rings

- Check all O-rings for cracks or distortion. Replace if worn.

Reverse Idler Gear Assemblies

- Check for excessive wear from action of roller bearings.

Sliding Clutches

- Check all shift yokes and yoke slots in sliding clutches for extreme wear or discoloration from heat.
- Check engaging teeth of sliding clutches for partial engagement pattern.

Splines

- Check splines on all shafts for abnormal wear. If sliding clutch gears, companion flange, or clutch hub has wear marks in the spline sides, replace the specific shaft affected.

Synchronizer Assembly

- Check synchronizer for burrs, uneven and excessive wear at contact surface, and metal particles.
- Check blocker pins for excessive wear or looseness.
- Check synchronizer contact surfaces on the synchronizer cups for wear.

Washers

- Check surfaces of all washers. Washers scored or reduced in thickness should be replaced.

Torque Specifications

| Description | Torque |
|---|---------------------------------|
| TCM cover nuts - 13 mm (x4) | 8.8 - 10.4 Nm (6-8 lb-ft) |
| 74-Way Connector to TCM jack-screw - 7 mm (x1) | 3 - 4.0 Nm (26.6-35.4 lb-in) |
| MTM to Main Housing cap screws - 15 mm (x2), 13 mm (x18) | 44.5 - 51.5 Nm (33-38 lb-ft) |
| LCA to MTM cap screws - T45 Torx | 23 - 28 Nm (17-21 lb-ft) |
| Output Yoke retainer cap screw - 27 mm (x1) | 617 - 690 Nm (455-508 lb-ft) |
| Oil Fill Plug - 6 mm Hex (x1) | 24.5 - 29.5 Nm (18-22 lb-ft) |
| Oil Check Plug - 6 mm Hex (x1) | 24.5 - 29.5 Nm (18-22 lb-ft) |
| Oil Drain Plug - 6 mm Hex (x1) | 24.5 - 29.5 Nm (18-22 lb-ft) |
| Rear Bearing Cover to Rear Housing cap screws - 13 mm (x8) | 21 - 25 Nm (16-19 lb-ft) |
| Front Upper Countershaft Cover to Clutch Housing - 13 mm (x6) | 21 - 25 Nm (16-19 lb-ft) |
| Input Shaft Cover to Clutch Housing - 13 mm (x7) | 21 - 25 Nm (16-19 lb-ft) |
| Inertia Brake Cover to Clutch Housing - 13 mm (x6) | 21 - 25 Nm (16-19 lb-ft) |
| Rear Housing to Main Housing cap screws - 16 mm (x22) | 44.5 - 51.5 Nm (33-38 lb-ft) |
| PTO Cover to Main Housing cap screws - 18 mm (x8) | 69 - 81 Nm (51-60 lb-ft) |
| Main Housing to Clutch Housing cap screws - 16 mm (x25) | 44.5 - 51.5 Nm (33-38 lb-ft) |
| Output Speed Sensor to Rear Housing cap screws - 10 mm (x1) | 8.8 - 10.4 Nm (6-8 lb-ft) |
| Fluid Pressure Sensor (FPS) - 24 mm Hex (x1) | 26 - 30 Nm (19-22 lb-ft) |

| Description | Torque |
|---|---------------------------------|
| Clutch to flywheel cap screws - 15 mm (x12) | 53.5 - 67.7 Nm (40-50 lb-ft) |
| 8 Bolt PTO Cover to Main Housing Cap Screws - 18 mm (x8) | 69 - 81 Nm (51 - 60 lb-ft) |
| Rear Housing to Main Case Stubbed Cap Screws - 16 mm (x3) | 44 - 51 Nm (33-38 lb-ft) |
| Rear Housing to Main Case Cap Screw - 16 mm (x21) | 44 - 51 Nm (33-38 lb-ft) |
| Main Housing to Clutch Housing Cap Screws - 16mm (x25) | 44 -51 Nm (33-38 lb-ft) |
| Upper Lube Tube Cap Screw - 8 mm (x1) | 8 - 10 Nm (6-13 lb-ft) |
| Lower Lube Tube Cap Screw - 8 mm (x1) | 8 - 10 Nm (6-13 lb-ft) |
| Rail E Detent Plug - Zero Leak - 6mm Hex (x1) | 24 - 29 Nm (18-21 lb-ft) |
| Oil Pump Assembly to Main Housing Cap Screws - 13 mm (x8) | 21 - 23 Nm (16-18 lb-ft) |
| Reaction Plate Mounting Cap Screws - 13 mm (x4) | 21 - 25 Nm (16-19 lb-ft) |
| Release Yoke Pivot Pin - 30 mm (x1) | 130 - 140 Nm (95-101 lb-ft) |
| 4 Bolt Rear Mount PTO Cover to Rear Housing - 18 mm (x4) | 69 - 81 Nm (51-60 lb-ft) |
| Rear Housing Lube Tube to Rear Housing (Dual PTO Transmission Only) - 8 mm (x1) | 8.8 - 10.4 Nm (6-8 lb-ft) |
| Lifting Eye Bracket Mounting Cap Screws - 15 mm (x4) | 49.6 - 55.5 Nm (36-40 lb-ft) |
| Rear Speed Sensor Bracket Cap Screws - 10 mm (x3) | 8.8 - 10.4 Nm (6-9 lb-ft) |

Handling, Inspection and Cleaning of Parts

Handling

All components of the transmission require a clean environment. If parts are not immediately reinstalled into the transmission they should be stored in a clean container and covered with a lint free cloth.

The components associated with the Mechatronic Transmission Module (MTM) must be handled with care. These components are crucial to the functionality of the transmission and should be handled in a clean environment.

Inspection and Cleaning

Inspect all transmission components with care. If any damage is found during a component inspection, replace the component and do not reuse.

NOTICE: Debris, foreign material, or moisture allowed to enter into the vehicle air system or MTM air inlet port can cause solenoids and air actuated components to malfunction.

If any component is exposed to dirt, or foreign material, clean properly with a solvent based cleaner and dry with lint free cloth before installing in the transmission.

Replacing Parts

When replacement is necessary, use only genuine Eaton Transmission parts to assure continued performance and extended life from your unit. Any replacement part that is to be used to fix the transmission must first be cleaned with a solvent based cleaner to remove debris and dried with a lint free cloth before installation.

Recycling Parts and Oil

Recycling Parts

Properly dispose of transmission components (copper, aluminum, steel or iron components) that are not reused or returned for warranty. Used transmission components should be collected and recycled at an authorized facility.

Recycling Oil

Properly dispose of transmission oil. Used transmission oil should be collected and recycled at an authorized facility.

Note: Never dispose of oil by putting it in the trash or pouring it on the ground, into sewers, or into streams or bodies of water.

MTM Rail B, C and D Cylinder Inspection Procedure

Special Instructions

Perform this entire procedure only if guided here by Endurant HD Troubleshooting Guide TRTS0950: Fault Code 617, 740, 760 and/or 775

and

- MTM Serial Number is less than 12S22342093445

and

- MTM Part Number is A-10000715 or A-10002594

NOTICE: Ensure vehicle air system provides proper transmission air supply and air quality, refer to “Vehicle Maintenance Recommendations” on page 459. Failure to provide proper transmission air supply and air quality results in degraded transmission performance and transmission component damage.

Special Tools

None

Note: MTM removal and installation requires the transmission to be removed from the vehicle. Reference Endurant HD Service Manual TRSM0950, Transmission Removal Service Procedure.

Component Identification

MTM, Fore view

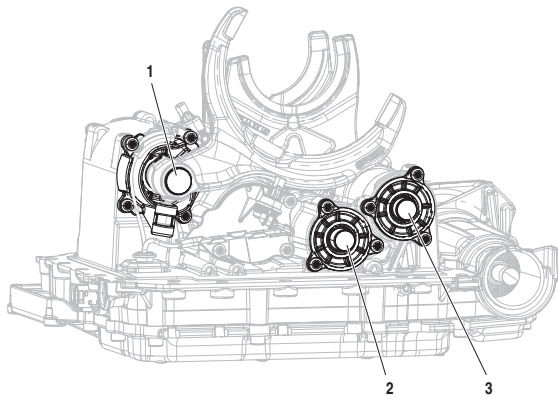

MTM, Aft view

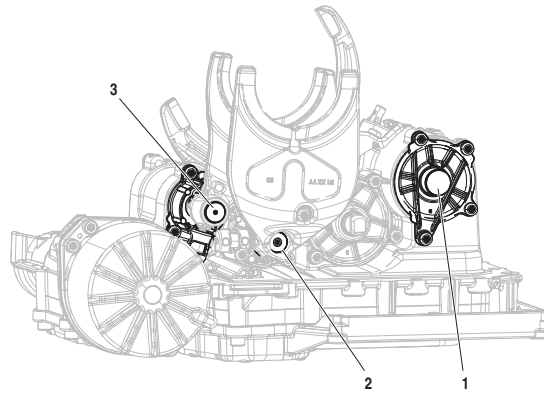

- 1. MTM Rail B
- 2. MTM Rail D
- 3. MTM Rail C

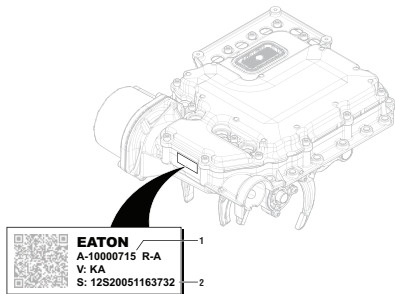

- 1. Part Number
- 2. Serial Number

Procedure - Inspection

1. Place MTM on a clean surface.
2. Visually inspect Rail B Cylinder covers (fore and aft) for loose cap screws, loose covers and/or protruding O-rings.
 - If no loose cap screws, covers, or protruding O-rings are found, go to Step 3.
 - If a loose cap screw, cover and/or protruding O-ring is found, go to Endurant HD Service Manual TRSM0950 MTM Rail B, C and D Cylinder on page 82.

Rail B Cylinder Cover Fore

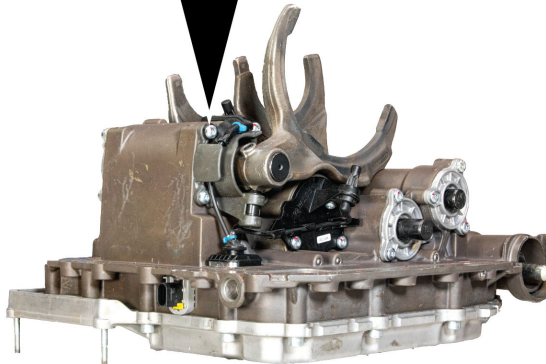

Rail B Cylinder Cover Aft

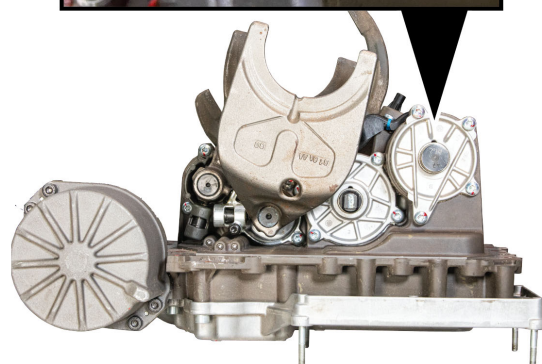
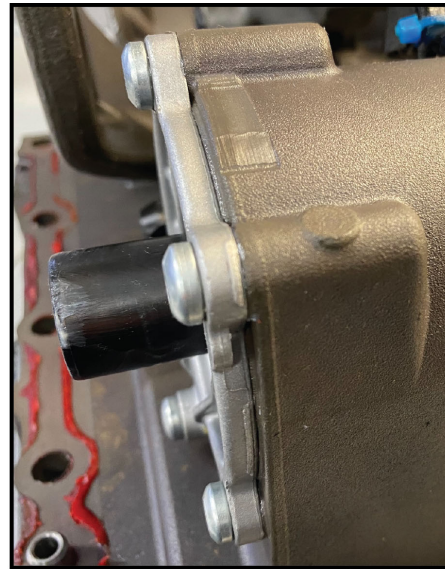

3. Visually inspect Rail C Cylinder covers (fore and aft) for loose cap screws, loose covers and/or protruding O-rings.
 - If no loose cap screws, covers, or protruding O-rings are found, go to Step 4.
 - If a loose cap screw, cover and/or protruding O-ring is found, go to Endurant HD Service Manual TRSM0950 MTM Rail B, C and D Cylinder on page 82.

Rail C Cylinder Cover Fore

Rail C Cylinder Cover Aft

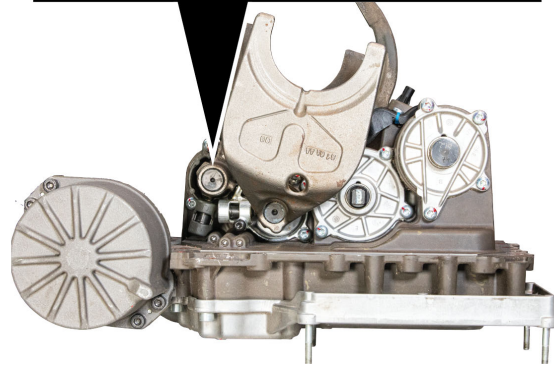
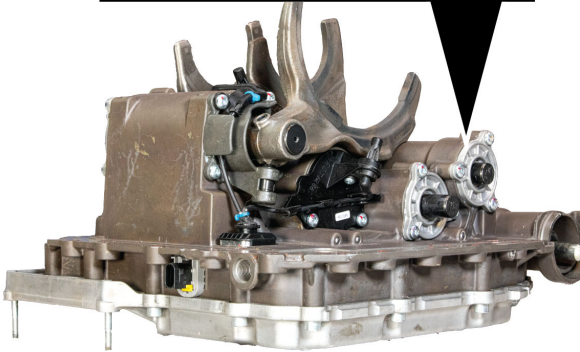
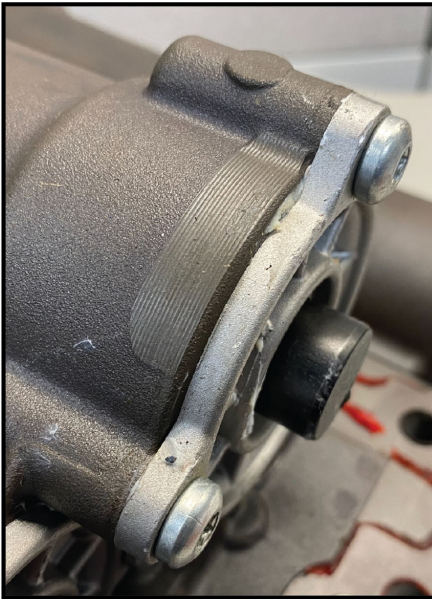

4. Visually inspect 3rd Rail C Cylinder cover Aft cap screw (not accessible).
 - If cap screw is visually tight, go to Step 5.
 - If cap screw is visually loose, go to Endurant HD Service Manual TRSM0950 MTM Rail B, C and D Cylinder on page 82.



5. Visually inspect Rail D Cylinder covers (fore and aft) for loose cap screws, loose covers and/or protruding O-rings.
 - If no loose cap screws, covers, or protruding O-rings are found, go to Step 6.
 - If a loose cap screw, cover and/or protruding O-ring is found, go to Endurant HD Service Manual TRSM0950 MTM Rail B, C and D Cylinder on page 82.

Rail D Cylinder Cover Fore

Rail D Cylinder Cover Aft

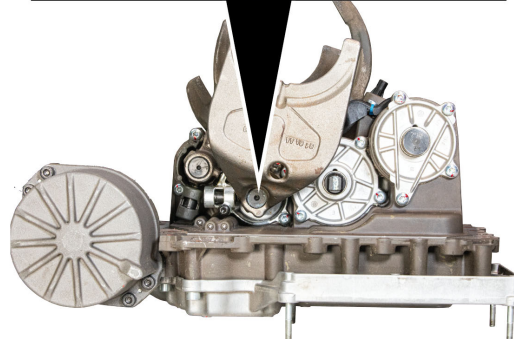
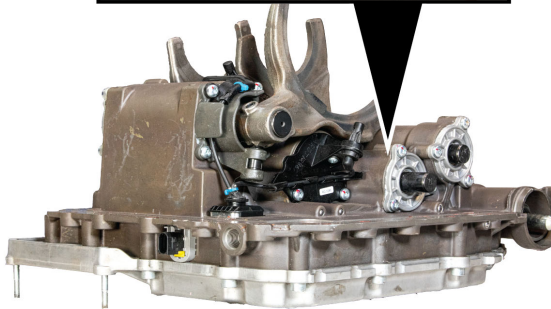
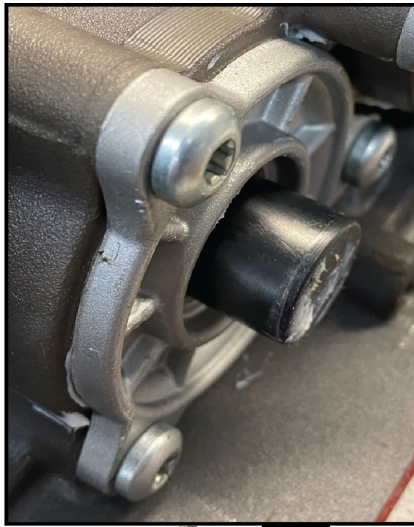

6. Determine next step:

- If guided here by Endurant HD Troubleshooting Guide TRTS0950: Fault Code 617 and no protruding O-rings or loose cover cap screws are found, go (return) to Endurant HD Troubleshooting Guide TRTS0950: Fault Code 617 Step H.
- If guided here by Endurant HD Troubleshooting Guide TRTS0950: Fault Code 740 and no protruding O-rings or loose cover cap screws are found, go (return) to Endurant HD Troubleshooting Guide TRTS0950: Fault Code 740 Step C.
- If guided here by Endurant HD Troubleshooting Guide TRTS0950: Fault Code 760 and no protruding O-rings or loose cover cap screws are found, go (return) to Endurant HD Troubleshooting Guide TRTS0950: Fault Code 760 Step C.
- If guided here by Endurant HD Troubleshooting Guide TRTS0950: Fault Code 775 and no protruding O-rings or loose cover cap screws are found, go (return) to Endurant HD Troubleshooting Guide TRTS0950: Fault Code 775 Step C.

Example of a loose Rail (C) Cylinder Cover with a protruding O-ring.

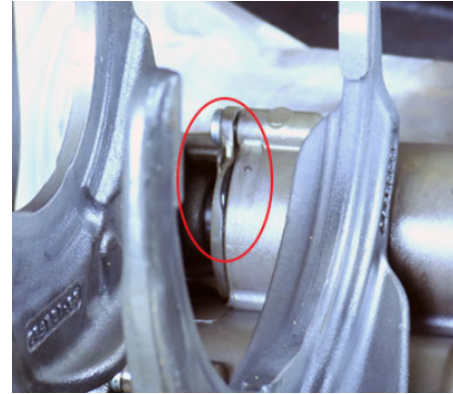

Example of a loose Rail (B) Cylinder Cover with a protruding O-ring.

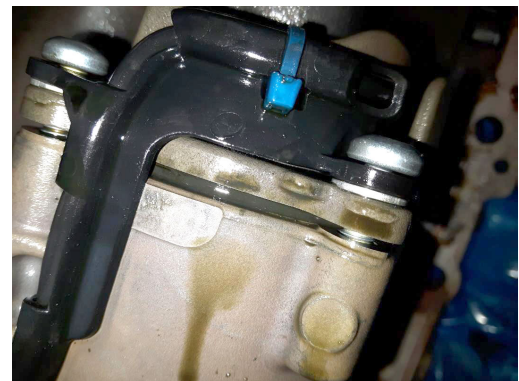

Example of a loose Rail (C) Cylinder Cover cap screw.



Warranty Information

1. Reference the relevant warranty information provided in service bulletin **TAIB-0994**

Main Shaft End-Play Service Procedure

Special Instructions

Main Shaft End-Play must be measured and adjusted after Clutch Housing, Main Housing, Input Shaft, Input Shaft Bearing or Main Shaft Bearing replacement.

 **CAUTION:** Failure to determine and install the Ideal Main Shaft Selective Washer results in incorrect Main Shaft End-Play resulting in transmission component damage.

Special Tools

- Torque Wrench
- 4 Flat Washers (22.3 mm (0.9 in) minimum OD)
- Dial Indicator
- 2 Pry Bars
- 5/32 OD Air Line
- Front Bearing Capture Plate (RR1085TR-7)
- Plastic Scraper
- Non-Chlorinated Brake Cleaner (Gasket Remover)

 **DANGER:** Do not handle non-chlorinated brake cleaner until all manufacturer precautions have been read and understood. Failure to follow precautions will result in serious personal injury or death.

 **CAUTION:** Avoid contact between non-chlorinated brake cleaner and the transmission plastic components, electrical wiring and connectors. Failure to avoid contact will result in transmission component damage.

Component Identification

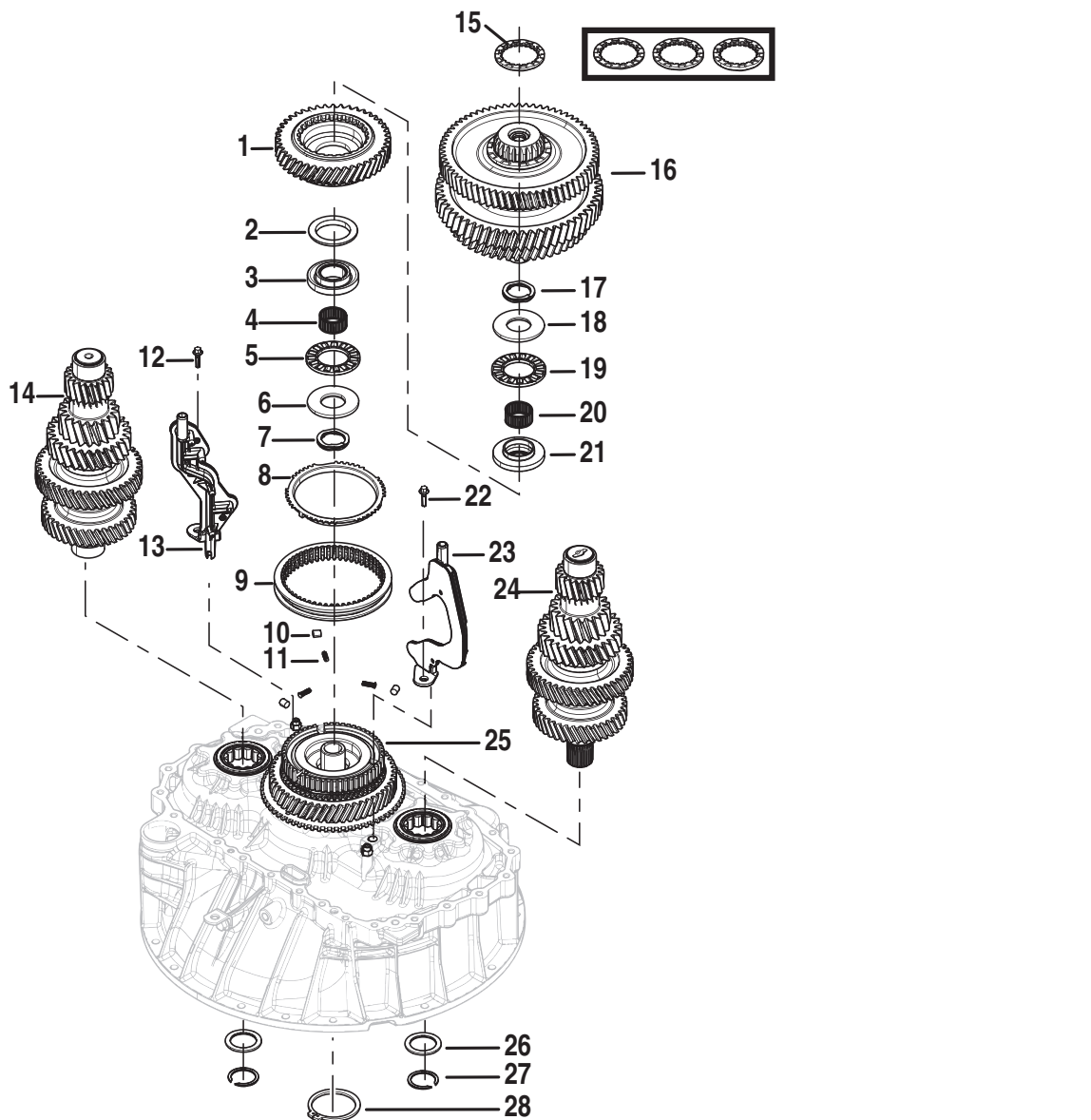

- | | | |
|--------------------------------|--|--------------------------------------|
| 1. Primary Drive Gear | 11. Synchronizer Springs and Plungers (x3) | 19. Thrust Bearing - Rear |
| 2. Spherical Washer - Front | 12. Lower Lube Tube Cap Screw - 8 mm | 20. Needle Bearing - Rear |
| 3. Bearing Race - Front | 13. Lower Lube Tube | 21. Bearing Race - Rear |
| 4. Needle Bearing - Front | 14. Upper Countershaft | 22. Upper Lube Tube Cap Screw - 8 mm |
| 5. Thrust Bearing - Front | 15. Main Shaft Selective Washer - 6.525 mm (0.257 in), 6.712 mm (0.264 in) or 6.900 mm (0.272 in) (x1) | 23. Upper Lube Tube |
| 6. Thrust Washer - Front | 16. Main Shaft Assembly | 24. Lower Countershaft |
| 7. Wave Spring - Front | 17. Wave Spring - Rear | 25. Input Shaft Assembly |
| 8. Synchronizer Ring | 18. Thrust Washer - Rear | 26. Countershaft Flat Washers (x2) |
| 9. Synchronizer Sliding Sleeve | | 27. Countershaft Snap Rings (x2) |
| 10. Synchronizer Rollers (x3) | | 28. Input Shaft Snap Ring |

Verify Components in the Clutch Housing



CAUTION: Clutch Housing weighs approximately 50 lbs. Keep fingers clear of pinch point between Clutch Housing and other surfaces. Dropping Clutch Housing could result in component damage and/or personal injury.

1. Verify Input Shaft Bearing is fully seated in Clutch Housing to ensure a proper Main Shaft End-Play reading.



2. Ensure Input Shaft Snap Ring is installed as instructed in the **Clutch Housing** to verify that the Input Shaft is fully seated.



3. Remove Input Shaft Snap Ring and install Front Bearing Capture Plate (RR1085TR-7) and torque to 21-25 Nm (16-19 lb-ft).

Note: The Input Shaft Bearing must be fully seated against the bearing stop in the Clutch Housing to ensure a proper Main Shaft End-Play reading.



4. Place and support Clutch Housing on a bench.

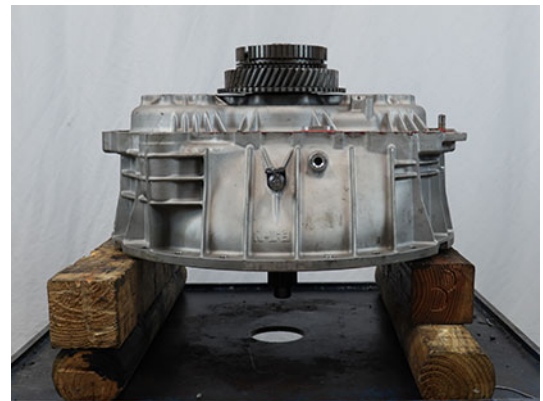

Install the Main Shaft and Countershaft

1. On the Secondary Drive Gear, apply paint marks on 2 gear teeth exactly 180-degrees across from each other, if not already marked.

Note: Paint marks are required for timing the Secondary Drive Gear to the Countershafts.



2. Install 3 springs and plungers into Synchronizer hub.



3. Install Rail B Synchronizer Sliding Sleeve with bevel facing up.

NOTICE: The tapered side of the sleeve is installed with the bevel facing up.



4. Lift and hold the Rail B Synchronizer Sliding Sleeve, install 3 rollers over the 3 springs and plungers and into the sliding sleeve groove.



5. Slowly press down the Synchronizer Sliding Sleeve to the neutral position and seat the 3 rollers evenly on the springs and plungers.



6. Install Rail B Synchronizer Ring.

Note: Align the 3 tabs on ring to the 3 openings on the hub at each spring and plunger.



7. Install Wave Spring - Front.

Note: Wave Spring - Front is taller than the Wave Spring - Rear.



8. Install Thrust Washer - Front.



9. Install Needle Bearing - Front.



10. Install Thrust Bearing - Front.**11. Install Bearing Race - Front.****12. Install Spherical Washer - Front with conical side down.****13. Install Lower Countershaft Pilot Tool (RR1071TR) to front section of Lower Countershaft.**

Note: Lower Countershaft has Inertia Brake Splines on the front and Oil Pump drive slot on the rear.



14. On the Lower Countershaft front drive gear, apply paint marks on the 2 gear teeth marked "0 0".

NOTICE: If the Secondary Drive Gear and countershaft front drive gears are not paint marked correctly, the gearing will not be properly timed and the Main Housing cannot be installed due to countershaft misalignment.

Note: Paint marks are required for timing the Secondary Drive Gear to the Countershafts.



15. Install Lower Countershaft with Countershaft Pilot Tool (RR1071TR). Ensure timing marks align with Secondary Drive Gear and Lower Countershaft front drive gear.



CAUTION: Countershaft weighs approximately 35 lbs. Keep fingers clear of pinch point between Countershaft and other surfaces. Dropping Countershaft could result in component damage and/or personal injury.

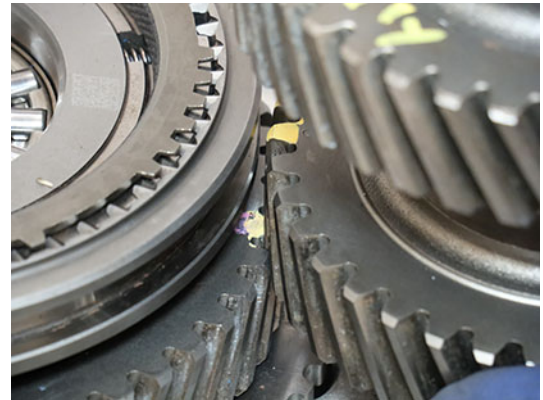
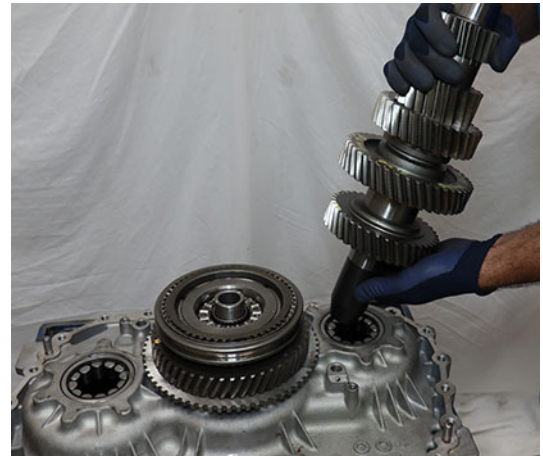

16. Install Upper Countershaft Pilot Tool (RR1072TR) to front section of Upper Countershaft.



17. On the Upper Countershaft front drive gear, apply paint marks on the 2 gear teeth marked "0 0".

NOTICE: If the Secondary Drive Gear and countershaft front drive gears are not paint marked correctly, the gearing will not be properly timed and the Main Housing cannot be installed due to countershaft misalignment.

Note: Paint marks are required for timing the Secondary Drive Gear to the Countershafts.



18. Install Upper Countershaft with Upper Countershaft Pilot Tool (RR1072TR) into bearing. Ensure timing marks align with Secondary Drive Gear and Upper Countershaft front drive gear.



CAUTION: Countershaft weighs approximately 35 lbs. Keep fingers clear of pinch point between Countershaft and other surfaces. Dropping Countershaft could result in component damage and/or personal injury.

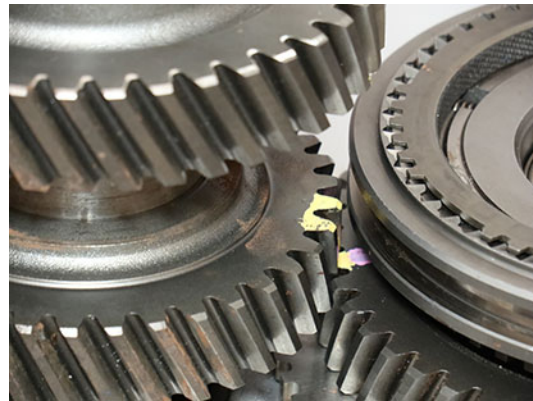

19. Install Primary Drive Gear with clutching teeth facing up onto Rail B Synchronizer.



20. Install Bearing Race - Rear.



21. Install Needle Bearing - Rear.



22. Install Thrust Bearing - Rear.



23. Apply transmission assembly lube to Wave Spring - Rear and install to Main Shaft.

NOTICE: Wave Spring - Rear is shorter than the Wave Spring - Front.

Note: Transmission assembly lube holds Wave Spring - Rear in place during Main Shaft Assembly installation.



24. Apply transmission assembly lube to Thrust Washer - Rear and install to Main Shaft.

Note: Transmission assembly lube holds Thrust Washer - Rear in place during Main Shaft Assembly installation.



25. Install a magnet onto the Main Shaft Key.

Note: The magnet holds the key in position during Main Shaft Assembly installation.



26. Slide and hold Rail C Sliding Clutch into Secondary Driven Gear.



27. Install Main Shaft Assembly onto Primary Drive Gear and align gearing.



CAUTION: Main Shaft weighs approximately 35 lbs. Keep fingers clear of pinch point between Main Shaft and other surfaces. Dropping Main Shaft could result in component damage and/or personal injury.



28. Remove magnet from Main Shaft Key.

NOTICE: Ensure to remove magnet or component damage may occur during assembly.



29. Install Upper Lube Tube into Clutch Housing and install 8 mm cap screw and torque to 8–10 Nm (6–13 lb–ft).



30. Install Lower Lube Tube into Clutch Housing and 8 mm cap screw, torque to 8–10 Nm (6–13 lb–ft).

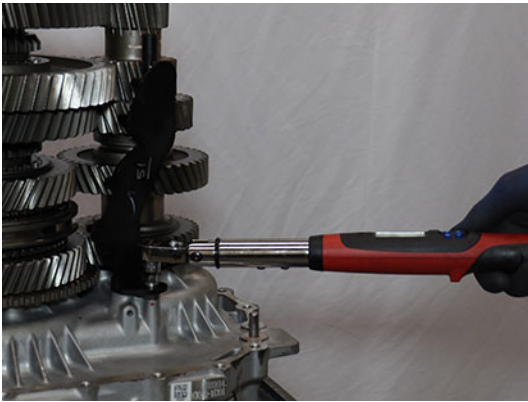

31. If Clutch Housing, Main Housing, Input Shaft, Input Shaft Bearing or Main Shaft Bearing has been replaced, perform steps to “Install the Main Housing without Gasket Sealant” on page 491 before measuring and adjusting Main Shaft End-Play. If these parts have NOT been replaced, perform “Install Main Housing” on page 509.

Install the Main Housing without Gasket Sealant

1. Clean the sealing surfaces on the Clutch Housing and Main Housing with gasket remover and a plastic scraper. Let air dry then wipe with a clean dry cloth.

NOTICE: Do not use abrasive scrapers or powered tools to clean sealing surfaces or sealing surfaces may be damaged and leak.

2. Inspect threaded bolt holes for debris and clean if necessary.

NOTICE: Ensure there is nothing in the threaded bolt holes or the transmission may be damaged when cap screws are tightened.

3. Slide O-ring over the Clutch Housing Inertia Brake air passage alignment pin until fully seated in groove.

NOTICE: Failure to install a new O-ring could result in degraded transmission performance.



4. Install Lower Countershaft Pilot Tool (RR1071TR) onto Lower Countershaft above rear bearing race.



5. Install Upper Countershaft Pilot Tool (RR1072TR) onto the Upper Countershaft above rear bearing race.



6. Install and hand tighten 2 Rear Housing 90-degree Lifting Eyes and 15 mm cap screws to Main Housing.

NOTICE: Do not over tighten Lifting Eye cap screws.

Note: Install 90-degree Lifting Eyes 180-degrees apart to ensure even lifting.

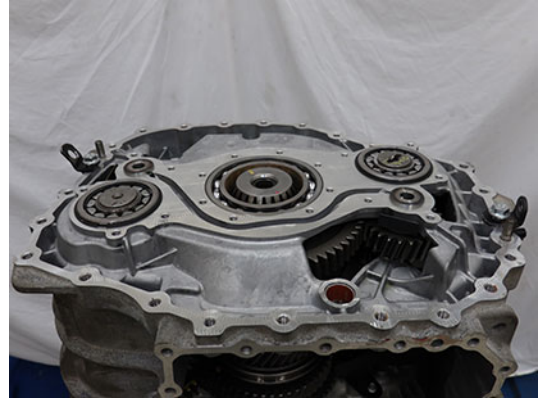

7. Install and hand tighten 2 Rear Housing Alignment Pins (RR1090TR) into the Clutch Housing as shown below.

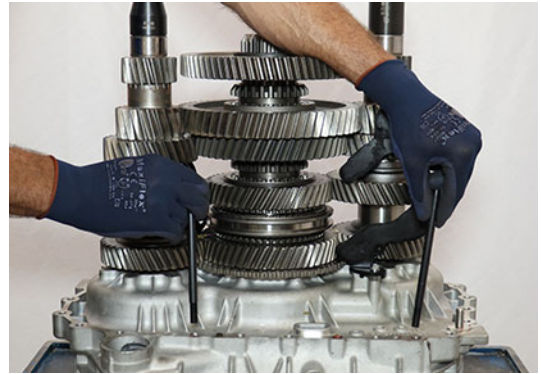

8. Lift, align and install Main Housing to Clutch Housing.



CAUTION: Main Housing weighs approximately 50 lbs. Keep fingers clear of pinch point between Main Housing and other surfaces. Dropping Main Housing could result in component damage and/or serious injury.

NOTICE: Use an appropriate lifting device to safely lift component.

Note: Using a flat tipped screwdriver, rotate the Reverse Idler Gears to align the gearing and allow Main Housing to fully seat onto the Clutch Housing.



9. Remove 2 Rear Housing Alignment Pins (RR1090TR).



10. Install 19 external and 6 internal Main Housing 16 mm cap screws and torque to 44–51 Nm (33–38 lb-ft) in a criss-cross pattern.

NOTICE: To avoid internal transmission contamination, keep internal and external Main Housing cap screws separated.

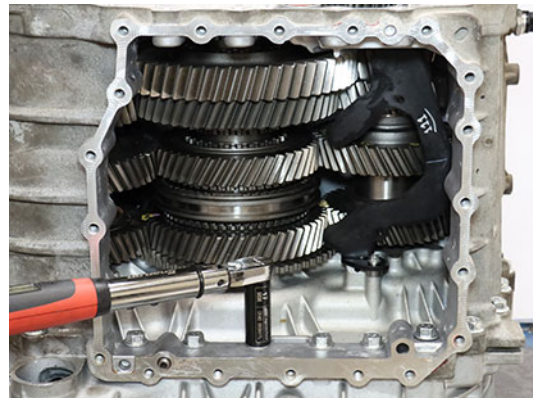

Measure and Adjust the Main Shaft End-Play

Note: The Main Shaft Selective Washer is available in 3 thicknesses: 6.525 mm (0.257 in), 6.712 mm (0.264 in) or 6.900 mm (0.272 in).

CAUTION: Ensure the Input Shaft Bearing and Main Shaft Bearing are seated in the Clutch Housing and Main Housing. Failure to fully seat bearings in housings will give an incorrect Main Shaft End-Play reading and may cause transmission component damage.

CAUTION: Ensure the 6.525 mm Main Shaft Selective Washer was installed. Only install a thicker selective washer after end-play has been measured and a thicker selective washer is required to achieve proper end-play or transmission damage may occur.

1. Install 4 Oil Pump 13 mm cap screws with flat washers (22.3 mm (0.9 in) minimum OD). Torque cap screws to 21-23 Nm (16-18 lb-ft).

Note: Flat washers are required to ensure the Main Shaft Bearing remains seated in the Main Housing during End-Play measurement.

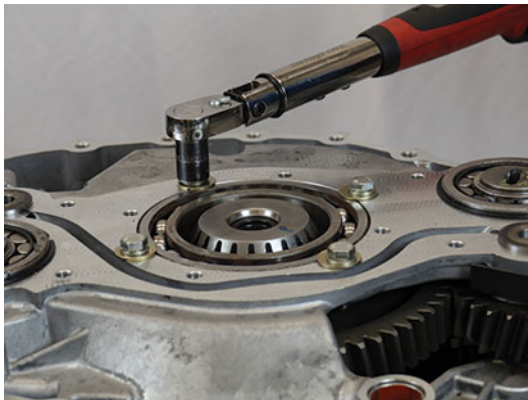

2. Thread a Dial Indicator mounting shaft into one of the inner Oil Pump mounting holes around the Main Shaft Bearing.

Note: The Oil Pump cap screw mounting holes thread pattern: M8 x 1.25 x 30 mm.



3. Mount the Dial Indicator to the shaft, set the plunger on the Main Shaft, and zero the Dial Indicator.

Note: Ensure that the Dial Indicator is vertical and zeroed for proper Main Shaft End-Play measurement.

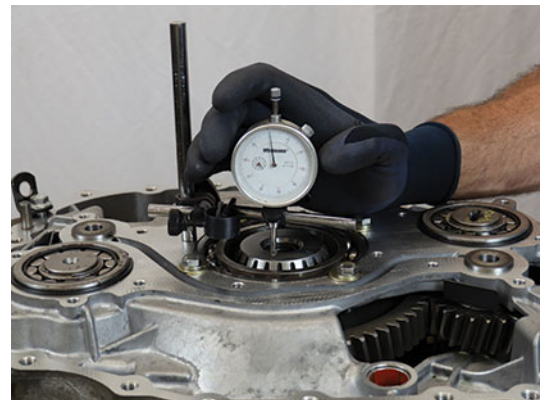

- Use two pry bars and slide them between the Reverse Gear and Main Housing at the locations shown below.

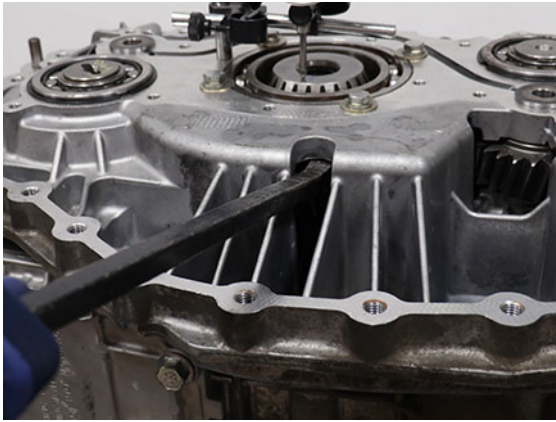

- Apply even downward pressure on Reverse Gear with both pry bars and monitor the Dial Indicator between the at-rest position of the Main Shaft and the point where no more downward movement is achieved. Record reading in table.

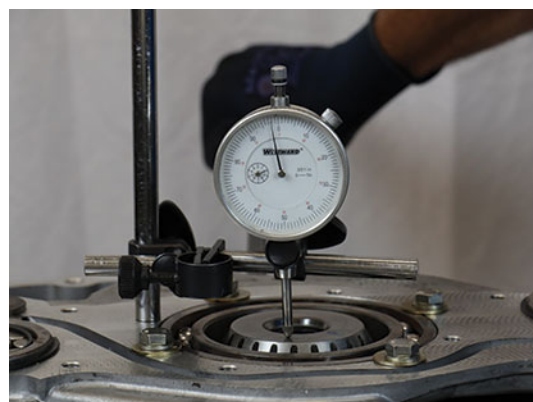

| |
|----------------------|
| Recorded End-Play |
| |

- Reference the Selective Main Shaft Washer Reference Chart and compare Recorded End-Play to reading in table.

Note: Main Shaft End-Play specification is 0.000-0.100 mm (0.000-0.004 in). The Selective Washer Chart is only valid for end-play measured with the 6.525 mm (0.257 in) selective washer installed.

- If end-play is in range, the installed Main Shaft Selective Washer, 6.525 mm (0.257 in), is correct.
- If end-play is out of range, determine the thicker ideal Main Shaft Selective Washer and record in table. Remove Main Shaft and install the Ideal Main Shaft Selective Washer.

Main Shaft Selective Washer Reference Chart

| Recorded End-Play | Ideal Main Shaft Selective Washer Thickness and Part Number |
|------------------------------------|---|
| 0.000-0.100 mm (0.000-0.004 in) | 6.525 mm (0.257 in) P/N 10000555 |
| 0.101-0.300 mm (0.005-0.011 in) | 6.712 mm (0.264 in) P/N 10001759 |
| 0.301-0.550 mm (0.012-0.021 in) | 6.900 mm (0.272 in) P/N 10001760 |

| Ideal Main Shaft Selective Washer |
|-----------------------------------|
| |

CAUTION: Main Shaft End-Play must be remeasured after replacing Main Shaft Selective Washer or transmission component damage may occur.

Remove Main Housing

- Remove the 19 external and 6 internal Main Housing 16 mm cap screws.

NOTICE: To avoid internal transmission contamination, keep internal and external Main Housing cap screws separated.



- Install and hand tighten 2 Rear Housing Alignment Pins (RR1090TR) in the internal Main Housing cap screw outer threaded holes.

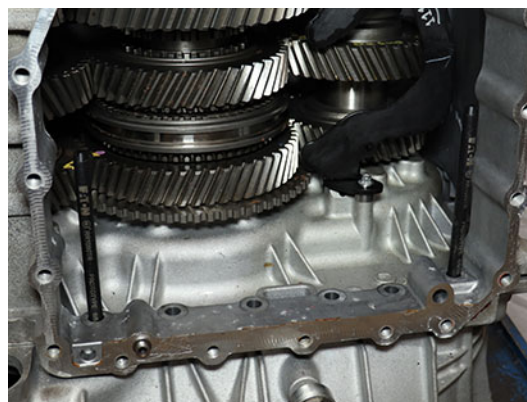

3. Separate Main Housing from Clutch Housing at the 2 pry points.



4. Lift and remove Main Housing from Clutch Housing.



CAUTION: Main Housing weighs approximately 50 lbs. Keep fingers clear of pinch point between Main Housing and other surfaces. Dropping Main Housing could result in component damage and/or personal injury.

NOTICE: Use an appropriate lifting device to safely lift component.



5. Remove 2 Rear Housing Alignment Pins (RR1090TR).

Note: Applying sealer when installing Main Housing to Clutch Housing should only be done after proper Main Shaft End-Play has been verified.



- Reference the Selective Main Shaft Washer Reference Chart and compare Recorded End-Play to reading in table.

Note: Main Shaft End-Play specification is 0.000-0.100 mm (0.000-0.004 in). The Selective Washer Chart is only valid for end-play measured with the 6.525 mm (0.257 in) selective washer installed.

- If end-play is in range, the installed Main Shaft Selective Washer, 6.525 mm (0.257 in), is correct.
- If end-play is out of range, determine the thicker Ideal Main Shaft Selective Washer and record in table. Remove Main Shaft and install the Ideal Main Shaft Selective Washer.

Main Shaft Selective Washer Reference Chart

| Recorded End-Play | Ideal Main Shaft Selective Washer Thickness and Part Number |
|------------------------------------|---|
| 0.000-0.100 mm (0.000-0.004 in) | 6.525 mm (0.257 in) P/N 10000555 |
| 0.101-0.300 mm (0.005-0.011 in) | 6.712 mm (0.264 in) P/N 10001759 |
| 0.301-0.550 mm (0.012-0.021 in) | 6.900 mm (0.272 in) P/N 10001760 |

| Ideal Main Shaft Selective Washer |
|-----------------------------------|
| |

CAUTION: Main Shaft End-Play must be remeasured after replacing Main Shaft Selective Washer or transmission component damage may occur.

Remove Main Shaft and Countershaft

- Remove the Upper Lube Tube 8 mm cap screw.



- Remove the Upper Lube Tube.



- Remove the Lower Lube Tube 8 mm cap screw.



4. Remove the Lower Lube Tube.



5. Install a magnet onto Main Shaft Key to ensure the key stays in place during Main Shaft Removal and Installation.



6. Hold Rail C Sliding Clutch against Secondary Driven Gear and lift Main Shaft from Primary Drive Gear.



CAUTION: Main Shaft weighs approximately 35 lbs. Keep fingers clear of pinch point between Main Shaft and other surfaces. Dropping Main Shaft could result in component damage and/or personal injury.

Note: Spring and Washer may remain attached to the Main Shaft during removal.



7. Remove Wave Spring - Rear.

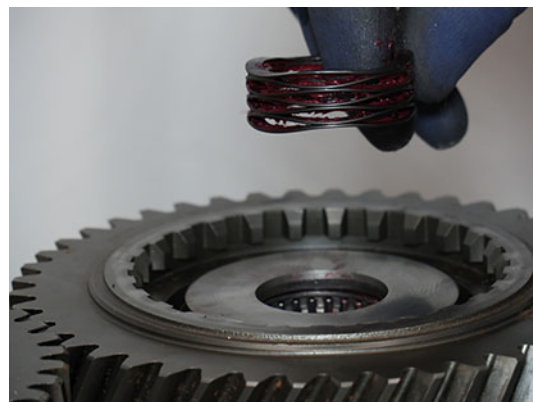

8. Remove Thrust Washer - Rear.**11. Remove Bearing Race - Rear.****9. Remove Thrust Bearing - Rear.****12. Remove Primary Drive Gear.****10. Remove Needle Bearing - Rear.**

13. Remove Lower Countershaft.

CAUTION: Countershaft weighs approximately 35 lbs. Keep fingers clear of pinch point between Countershaft and other surfaces. Dropping Countershaft could result in component damage and/or personal injury.

**14. Remove Upper Countershaft.**

CAUTION: Countershaft weighs approximately 35 lbs. Keep fingers clear of pinch point between Countershaft and other surfaces. Dropping Countershaft could result in component damage and/or personal injury.

**15. Remove Spherical Washer - Front.****16. Remove Bearing Race - Front.****17. Remove Needle Bearing - Front.**

18. Remove Thrust Bearing - Front.



19. Remove Synchronizer Ring.



20. Slowly lift Synchronizer Sliding Sleeve up until Synchronizer Rollers are free from synchronizer assembly.

NOTICE: Rollers are under spring pressure, ensure to slowly lift sleeve so rollers do not eject from the synchronizer assembly during disassembly.



21. Remove 3 Synchronizer Rollers.



22. Remove 3 Synchronizer Plungers and Springs from Synchronizer hub.

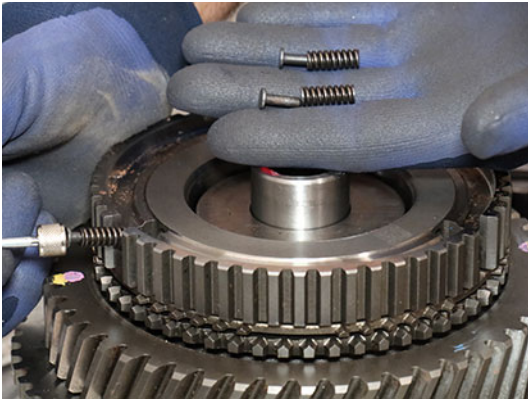

23. Remove Thrust Washer - Front.



24. Remove Wave Spring - Front.



Disassemble the Main Shaft and Replace Main Shaft Selective Washer

Note: This procedure is only required if Main Shaft End-Play is out of range and a thicker Selective Washer is required.

1. Place Main Shaft Assembly horizontally on a clean flat surface.



CAUTION: Secure Main Shaft Assembly while on flat surface to avoid unexpected movement. Failure to properly secure Main Shaft Assembly could result in component damage and/or personal injury.

2. Remove Rail C Sliding Clutch.

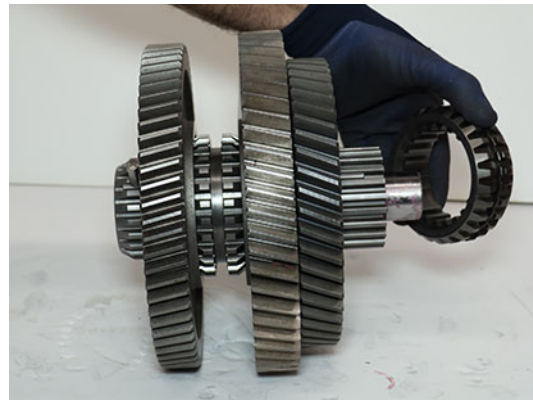

3. Place Main Shaft assembly vertically on a clean flat surface.



CAUTION: Secure Main Shaft Assembly while on flat surface to avoid unexpected movement. Failure to properly secure Main Shaft Assembly could result in component damage and/or personal injury.



- Remove Main Shaft Key while inserting 5/32 OD air line.



- Rotate and remove the Main Shaft Selective Washer above Reverse Gear.

Note: The Main Shaft Selective Washer above Reverse Gear is available in 3 thicknesses; 6.525, 6.712 or 6.900 mm to control Main Shaft End-Play.



Assemble and Install the Main Shaft with Replaced Main Shaft Selective Washer

- Install and rotate the Ideal Main Shaft Selective Washer above Reverse Gear recorded in Step 6 of the Main Shaft End-Play Service Procedure.

Note: The Main Shaft Selective Washer is available in 3 thicknesses: 6.525, 6.712 or 6.900 mm.



- Slide the 5/32 OD air line up to align and hold washer in place.



3. Install Main Shaft Key at the same spline as the 5/32 OD air line.

Note: Insert Main Shaft Key while removing air line.



4. Install a magnet on Main Shaft Key to hold the key in place during final Main Shaft Assembly and installation into transmission.

Note: Remove magnet from Main Shaft Key after installation of Main Shaft Assembly onto transmission.



5. Place Main Shaft Assembly horizontally on a clean flat surface.



CAUTION: Secure Main Shaft Assembly while on flat surface to avoid unexpected movement. Failure to properly secure Main Shaft Assembly could result in component damage and/or personal injury.

6. Install Rail C Sliding Clutch and align the double slot with Main Shaft Key.

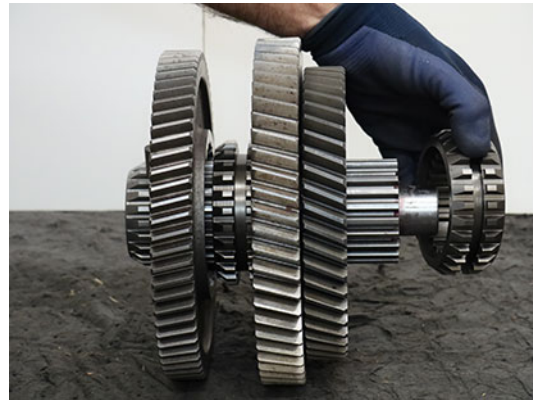
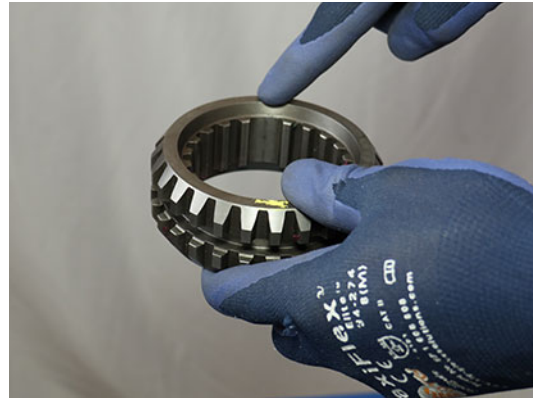

7. Apply transmission assembly lube to Wave Spring - Rear and install to Main Shaft.

NOTICE: Wave Spring - Rear is shorter than the Wave Spring - Front.

Note: Transmission assembly lube holds Wave Spring - Rear in place during Main Shaft Assembly installation.



8. Apply transmission assembly lube to Thrust Washer - Rear and install to Main Shaft.

Note: Transmission assembly lube holds Thrust Washer - Rear in place during Main Shaft Assembly installation.



9. Install a magnet onto the Main Shaft Key.

Note: The magnet holds the key in position during Main Shaft Assembly installation.



10. Slide and hold Rail C Sliding Clutch into Secondary Driven Gear.



11. Install Main Shaft Assembly onto Primary Drive Gear and align gearing.



CAUTION: Main Shaft weighs approximately 35 lbs. Keep fingers clear of pinch point between Main Shaft and other surfaces. Dropping Main Shaft could result in component damage and/or personal injury.



12. Remove magnet from Main Shaft Key.

NOTICE: Ensure to remove magnet or component damage may occur during assembly.



13. If removed, install Upper Lube Tube into Clutch Housing and install 8 mm cap screw and torque to 8–10 Nm (6–13 lb–ft).



14. If removed, install Lower Lube Tube into Clutch Housing and 8 mm cap screw, torque to 8–10 Nm (6–13 lb–ft).

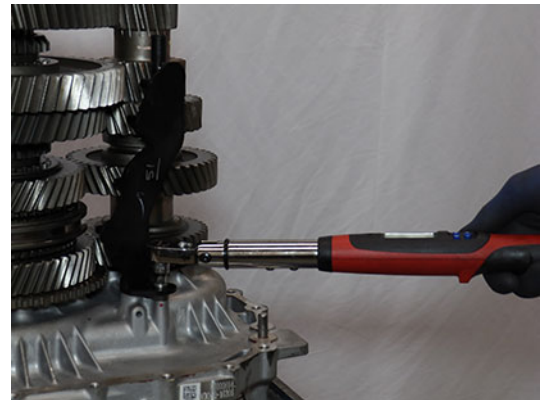

15. Perform steps to **Install the Main Housing without Gasket Sealant** and remeasure Main Shaft End-Play.



CAUTION: Main Shaft End-Play must be remeasured after replacing Main Shaft Selective Washer or transmission component damage may occur.

Install Main Housing

1. Clean the sealing surfaces on the transmission Main Housing and Rear Housing with gasket remover and a plastic scraper. Let air dry then wipe with a clean dry cloth.

NOTICE: Do not use abrasive scrapers or powered tools to clean sealing surfaces or sealing surfaces may be damaged and leak.

2. Inspect threaded bolt holes for debris and clean if necessary.

NOTICE: Ensure there is nothing in the threaded bolt holes or the transmission may be damaged when cap screws are tightened.

3. Slide O-ring over the Clutch Housing Inertia Brake air passage alignment pin until fully seated in groove.

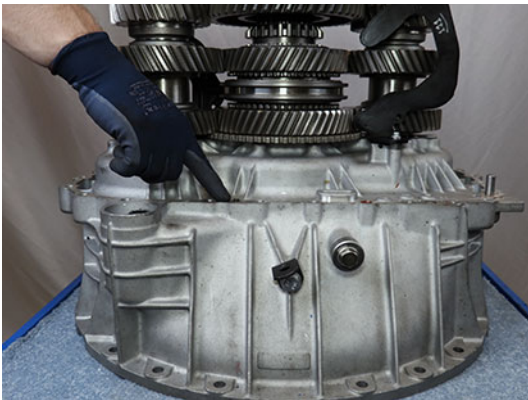

4. Apply gasket sealant with a bead width of 1.4-2.4 mm (0.055-0.094 inch) to clutch housing as shown in pattern below.

NOTICE: Ensure there is nothing in the threaded bolt holes or the transmission may be damaged when cap screws are tightened.

Note: Parts must be assembled within 10 minutes of applying gasket sealant.

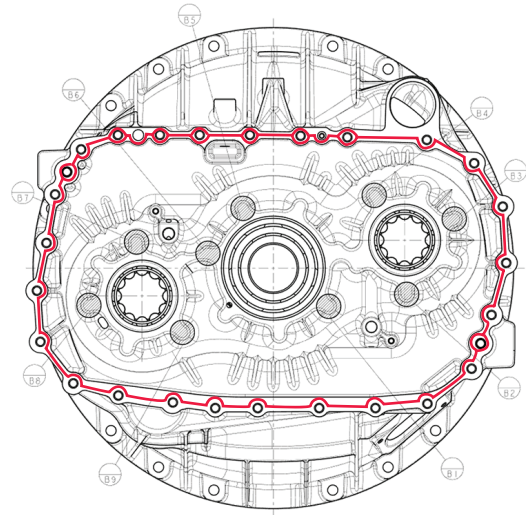

5. Install Lower Countershaft Pilot Tool (RR1071TR) onto Lower Countershaft above rear bearing race.



6. Install Upper Countershaft Pilot Tool (RR1072TR) onto the Upper Countershaft above rear bearing race.



7. Install and hand tighten 2 Rear Housing 90-degree Lifting Eyes and 15 mm cap screws to Main Housing.

NOTICE: Do not over tighten Lifting Eye cap screws.

Note: Install 90-degree Lifting Eyes 180-degrees apart to ensure even lifting.

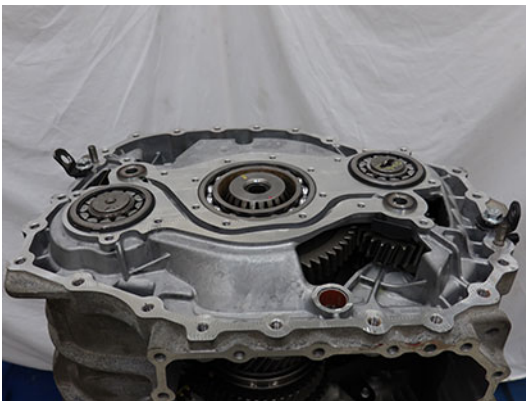

8. Install and hand tighten 2 Rear Housing Alignment Pins (RR1090TR) into the Clutch Housing as shown below.

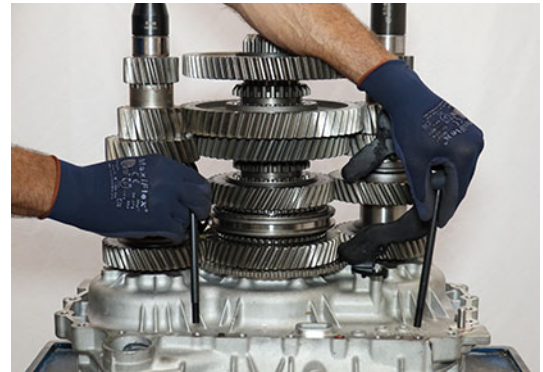

9. Lift, align and install Main Housing to Clutch Housing.



CAUTION: Main Housing weighs approximately 50 lbs. Keep fingers clear of pinch point between Main Housing and other surfaces. Dropping Main Housing could result in component damage and/or serious injury.

NOTICE: Use an appropriate lifting device to safely lift component.

Note: Using a flat tipped screwdriver, rotate the Reverse Idler Gears to align the gearing and allow Main Housing to fully seat onto the Clutch Housing.



10. Remove 2 Rear Housing Alignment Pins (RR1090TR).



11. Remove 2 Rear Housing 90-degree Lifting Eyes and 15 mm cap screws from Main Housing.



12. Re-install 2 Rear Housing 90-degree Lifting Eyes to the Rear Housing and torque to 49.6-55.5 Nm (36-40 lb-ft).



13. Install 19 external and 6 internal Main Housing 16 mm cap screws and torque to 44–51 Nm (33–38 lb–ft) in a criss-cross pattern.

NOTICE: To avoid internal transmission contamination, keep internal and external Main Housing cap screws separated.

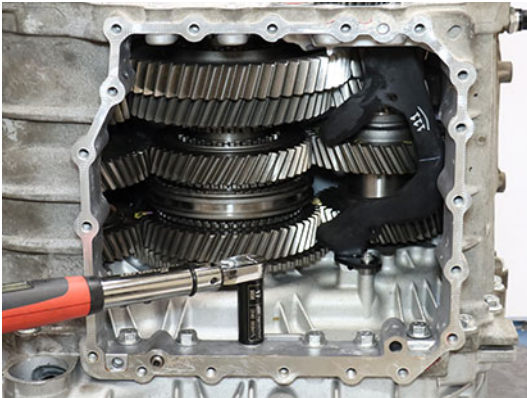

Install the Oil Pump Assembly

1. Install O-ring to the Oil Pump/Range Spacer.



2. Install Oil Pump/Range Spacer with O-ring and align tab with groove in Oil Pump Assembly.

NOTICE: Ensure the spacer tab is aligned with the groove and the spacer sits flush in the Oil Pump Assembly.



3. While holding the Oil Pump/Range Spacer in place, align oil pump drive key with slot on Lower Counter-shaft and install Oil Pump Assembly to Main Housing.



CAUTION: Failure to properly install the Oil Pump/Range Spacer and align the oil pump drive key results in transmission component damage during Oil Pump Assembly installation.

NOTICE: Ensure oil pump drive key is aligned with counter shaft drive slot during Oil Pump Assembly installation.



4. Press Oil Pump Assembly to ensure it sits flat on Main Housing sealing surface.



5. Install 18 Oil Pump Assembly 13 mm cap screws and torque to 21–23 Nm (16–18 lb–ft) in a criss-cross pattern.

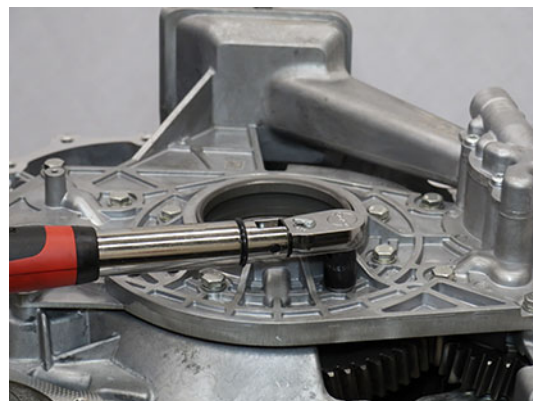

Install the Rear Housing

1. Clean the sealing surfaces on the transmission Main Housing and Rear Housing with gasket remover and a plastic scraper. Let air dry then wipe with a clean dry cloth.

NOTICE: Do not use abrasive scrapers or powered tools to clean sealing surfaces or sealing surfaces may be damaged and leak.

2. Inspect threaded bolt holes for debris and clean if necessary.
3. Apply Gasket Sealant with a bead width of 1.4-2.4 mm (0.055-0.094 inch) to the transmission Main Housing sealing surface following the pattern below.

NOTICE: Ensure there is nothing in the threaded bolt holes or the transmission housing may be damaged when cap screws are tightened.

Note: Parts must be assembled within 10 minutes of applying Gasket Sealant.

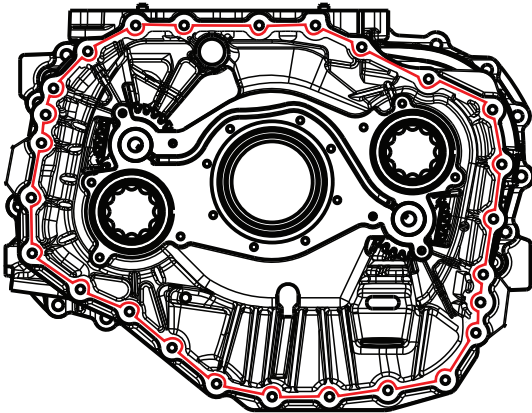

4. Install and hand tighten 2 Rear Housing Alignment Pins (RR1090TR) 180-degrees apart.



CAUTION: Failure to install alignment pins results in transmission component damage during Rear Housing Assembly installation.

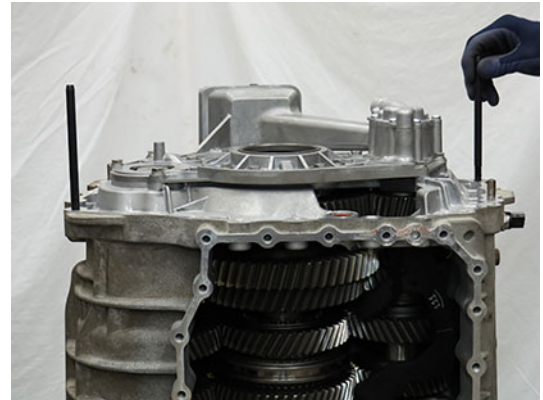

5. Lift and install the Rear Housing Assembly on to the Main Housing.



WARNING: Rear Housing Assembly weighs approximately 170 lbs. Failure to properly secure and lift the Rear Housing may result in major vehicle component damage, severe injury or death.

NOTICE: Use an appropriate lifting device to safely lift component.

Note: Align the Rear Housing to the alignment pins and align Shift Rail E into the Main Housing during installation.

Note: Rotate Output Shaft to align gearing and allow Rear Housing Assembly to fully seat on Main Housing.



6. Install the 3 Rear Housing Threaded 16 mm cap screws at the 3 paint mark locations.

Note: Two cap screws are used to mount the harness bracket and the third is used by the OEM for additional attachment points.



7. Remove the 2 Rear Housing Alignment Pins (RR1090TR).
8. Install the remaining 21 Rear Housing 16 mm cap screws and torque to 44.5 - 51.5 Nm (33-38 lb-ft) in a criss-cross pattern.



9. Lift transmission horizontally onto a bench.



WARNING: Transmission weighs approximately 550 lbs. Keep fingers clear of pinch point between transmission and other surfaces. Dropping transmission may result in major vehicle component damage, severe injury or death.

NOTICE: Use an appropriate lifting device to safely lift component.

Secure Transmission (Horizontal)

1. Securely place transmission in the horizontal position with the front side down.



WARNING: Transmission weighs approximately 550 lbs. Keep fingers clear of pinch point between transmission and other surfaces. Dropping transmission may result in major vehicle component damage, severe injury or death.

NOTICE: Use an appropriate lifting device to safely lift component.

Install the Input Shaft Snap Ring

1. Remove Front Bearing Capture Plate (RR1085TR-7) from Clutch Housing.



2. Install Input Shaft Snap Ring.

NOTICE: A new snap ring is required when reinstalling. A used snap ring may detach from Input Shaft and result in transmission component damage.

Note: The snap ring will not install if Input Shaft is not fully seated into Input Shaft Bearing.



Install the Input Shaft Cover

1. Clean sealing surfaces on the clutch housing and Input Shaft Cover.
2. Slide the Input Shaft Cover over the Input Shaft.

Note: Align “TOP” at 12 o’clock.



3. Install the 7 Input Shaft Cover 13 mm cap screws and torque to 21-25 Nm (16-19 lb-ft) in a criss-cross pattern.

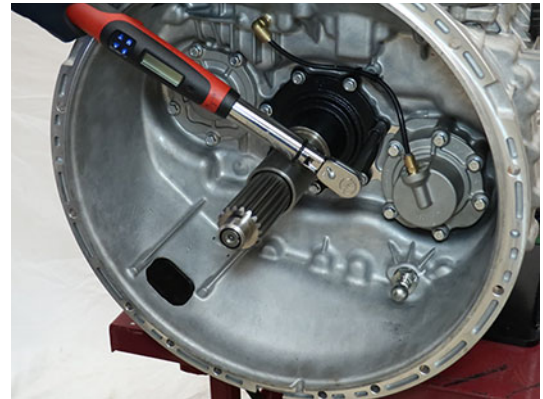

Install Lower Countershaft Snap Ring and Flat Washer

1. Install Lower Countershaft Flat Washer and Snap Ring.

NOTICE: A new snap ring is required when reinstalling. A used snap ring may detach from Countershaft and result in transmission component damage.



Install the Lower Countershaft Cover and Inertia Brake

1. Clean sealing surfaces on the Clutch Housing and Inertia Brake Housing.
2. Install the Inertia Brake Cover and Housing as an assembly over the Lower Countershaft, rotate the assembly to align the Friction Discs to the Lower Countershaft splines and seat the assembly to the clutch housing.

Note: Reference “RRMT0027 - Clutch Housing Front Cover Kit” on page 586 for new Inertia Brake Housing part number, additional O-ring part number, and installation instructions.



3. While holding the Inertia Brake Housing to the clutch housing, remove the Inertia Brake Cover.

NOTICE: Ensure the Friction Discs are splined to the lower countershaft and Wear Guides are fully seated.



4. Install the Return Spring into the Lower Countershaft.



7. Install the 6 13 mm cap screws and torque to 21-25 Nm (16-19 lb-ft) in a criss-cross pattern.



5. Install the Piston Pin into the Lower Countershaft.



8. Insert air line in push-to-connect fitting on the Inertia Brake Cover.



6. Install the Inertia Brake Cover onto the housing.



Install Upper Countershaft Snap Ring and Flat Washer

1. Install Upper Countershaft Flat Washer and Snap Ring.

NOTICE: A new snap ring is required when reinstalling. A used snap ring may detach from countershaft and result in transmission component damage.



Install the Upper Countershaft Cover

1. Clean the sealing surfaces on the clutch housing and the Upper Countershaft Cover.

Note: A new Upper Countershaft Cover Seal is required when reinstalling or an oil leak may occur. Reference “RRMT0027 - Clutch Housing Front Cover Kit” on page 586 for new Upper Countershaft Cover part number, additional O-ring part number, and installation instructions.

2. Insert the Upper Countershaft Cover Seal into the groove until fully seated.



3. Install the Upper Countershaft Cover to the Clutch Housing.

4. Install the six 13 mm cap screws and torque to 21-25 Nm (16-19 lb-ft) in a criss-cross pattern.



Install the Harness Bracket

Note: This procedure contains installing the Harness Bracket without the Mechatronic Transmission Module (MTM).

1. Install Harness Bracket.



2. Install 3 Harness Bracket 10 mm cap screws and torque to 8.8 - 10.4 Nm (6-8 lb-ft).



Install the Output Speed Sensor

1. Clean the sensor bore.

NOTICE: Do not use abrasive scrapers or powered tools to clean sealing surface.

2. Apply a light coat of transmission oil to the sensor O-ring.
3. Install the Output Speed Sensor into the bore.

Note: The Sensor may need to be twisted and pushed into the bore.



4. Install the Output Speed Sensor 10 mm cap screw and torque to 8.8-10.4 Nm (6-8 lb-ft).



5. Press the 2 harness press-in retainers into the Main Housing and the bracket on the rear housing.

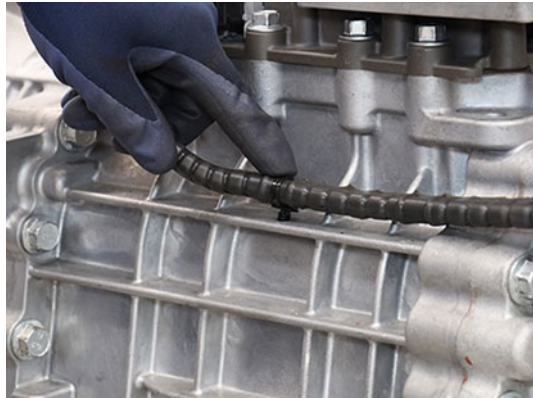

6. Secure the Output Speed Sensor Harness to the Harness Bracket with a tie strap.



CAUTION: Failure to tie strap the Output Speed Sensor Harness to the Harness Bracket may result in harness damage.

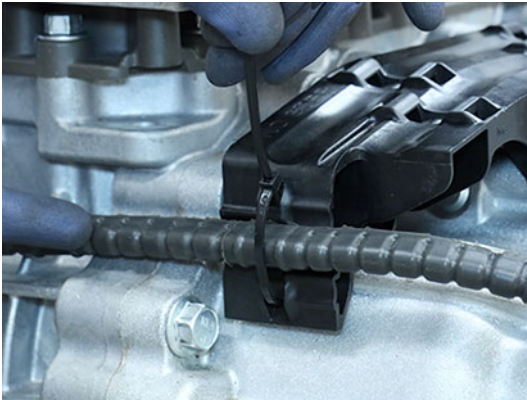

Install the Mechatronic Transmission Module (MTM)

Note: If replacing original equipment MTM with new/replacement MTM locate new/replacement MTM part information tag and record Part Number and Serial Number. Refer to Component Identification section. Part Number and Serial Number are required to properly configure TCM after MTM installation.

1. Place the transmission in a horizontal position.

NOTICE: The transmission must be in a horizontal position prior to the MTM Installation procedure. Failure to do so causes the sliding clutches to move out of neutral and not align to the shift yokes. If the shift yokes are not aligned to the sliding clutches, position sensor fault codes set Active and the transmission will not shift out of neutral.

2. Clean the sealing surfaces on the transmission and Mechatronic Transmission Module (MTM) with gasket remover and a plastic scraper. Let air dry then wipe with a clean dry cloth.

NOTICE: Do not use abrasive scrapers or powered tools to clean sealing surfaces or sealing surfaces may be damaged and leak.

3. Inspect threaded bolt holes for debris and clean if necessary.

NOTICE: Ensure there is nothing in the threaded bolt holes or the transmission may be damaged when cap screws are tightened.

4. Install the Rail B Engagement Tool (RR1088TR) to the Main Housing and hand tighten with 2 MTM cap screws.



5. Shift the Rail B Synchronizer to neutral.

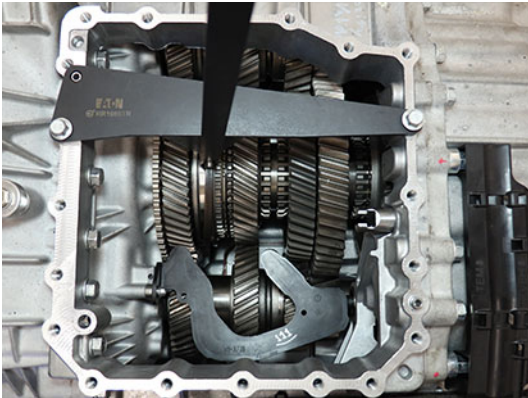

8. Install the Confirm-Neutral Gauge (RR1086TR-2) into the slots of the synchronizer and sliding clutches.



6. Remove the Rail B Engagement Tool.
7. Move Rail C and Rail D sliding clutches to neutral.

NOTICE: The transmission must be in a horizontal position prior to the MTM Installation procedure. Failure to do so causes the sliding clutches to move out of neutral and not align to the shift yokes. If the shift yokes are not aligned to the sliding clutches, position sensor fault codes set Active and the transmission will not shift out of neutral.

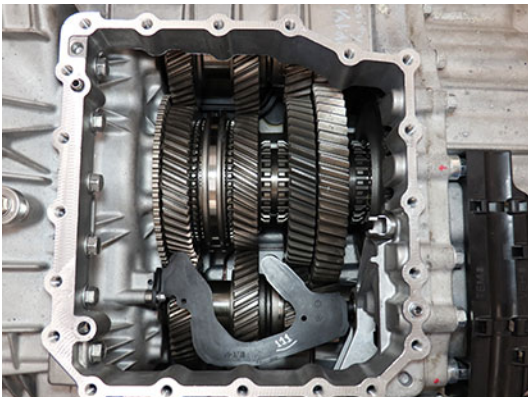
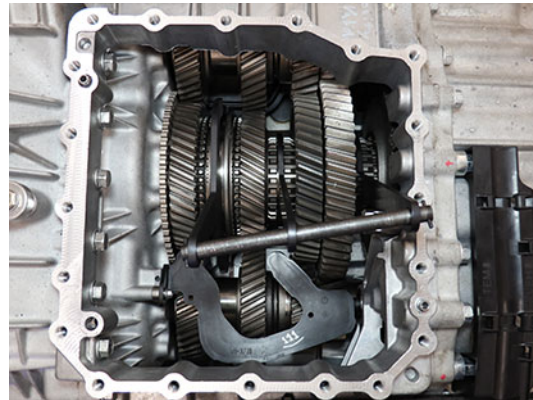

9. Install the MTM Alignment Tool (RR1086TR-1) onto the main housing.

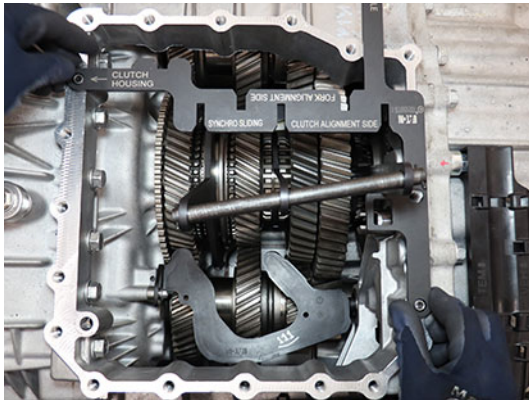
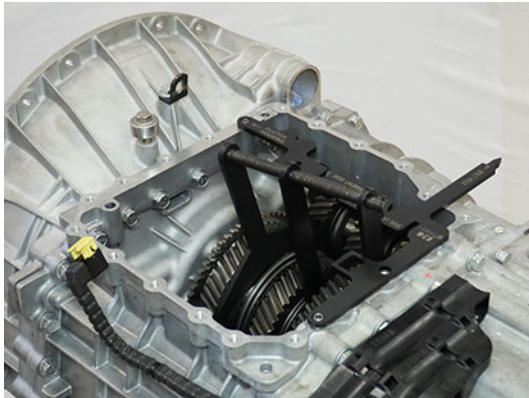

10. Verify synchronizer and sliding clutches are in neutral by sliding Confirm-Neutral Gauge into the slots of MTM Alignment Tool.

Note: If the gauge does not slide into the alignment tool slots, neutral is not achieved. Go to Step 4.

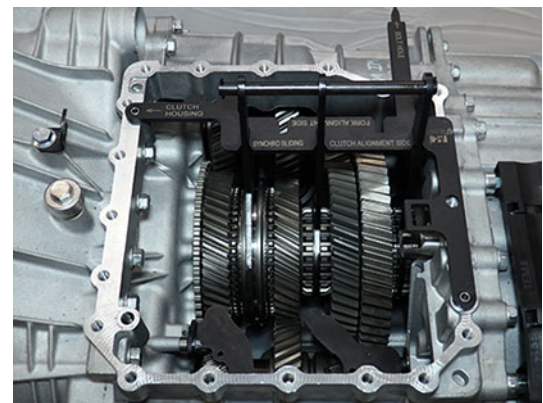

11. Using the Rail E Lever, move Rail E to neutral.

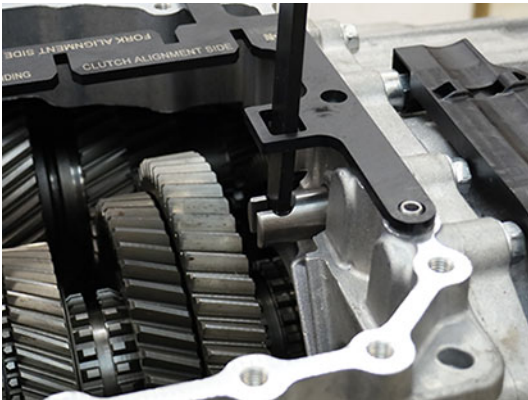
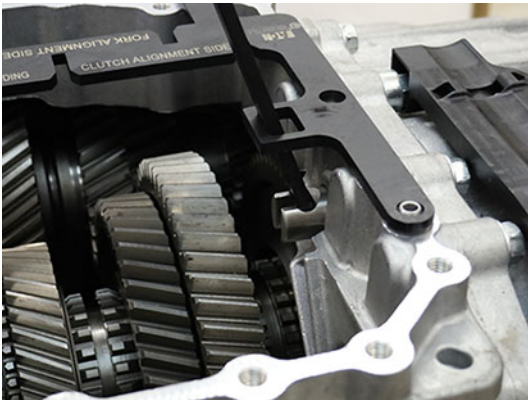
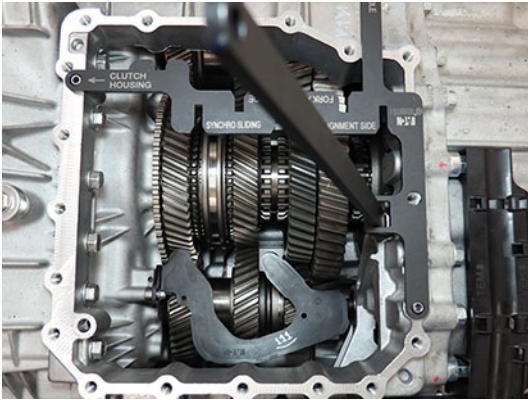

12. Verify Rail E is in neutral using the Gear Side Actuator end of the Confirm-Neutral Gauge (RR1088TR-2) at Shift Rail E. Rail E is in neutral when end of gauge rests against housing with rail against notch-end of gauge.

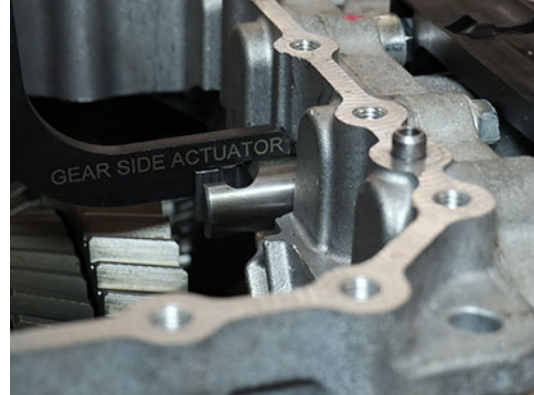

13. Move Shift Rail B in the MTM to neutral. Rail B is in neutral when the ball detent is in the notch of the Rail B yoke assembly.

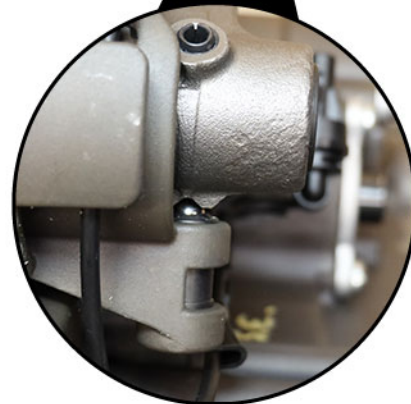
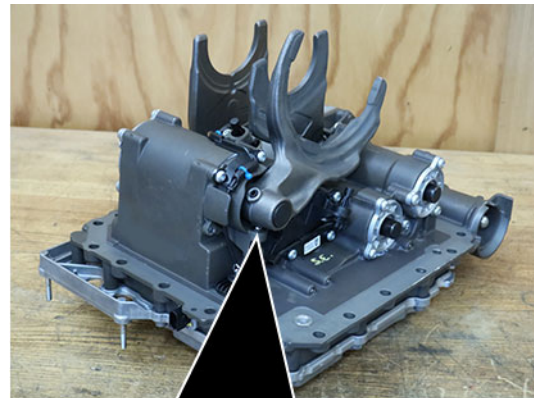

14. Move Shift Rails C and D in the MTM to neutral. Rails C and D are in neutral when the shift inter-lock is aligned with the notches of the rail yoke assemblies.

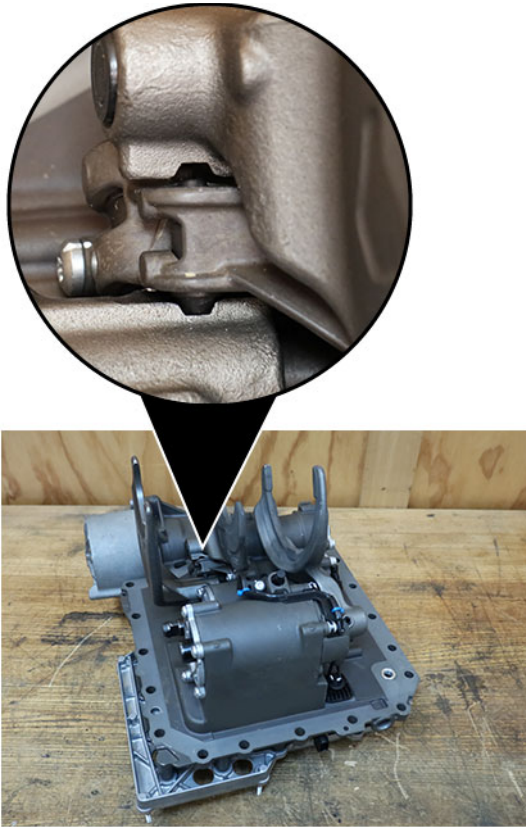

15. Verify MTM is in neutral. Install the MTM Alignment Tool (RR1086TR-1) into the bolt hole and onto Rail B, C, and D Shift Yokes.

Note: If the MTM Alignment Tool slots do not align with the 3 shift yokes, neutral has not been achieved. Go to Step 13.



16. Verify notch on Rail E is facing up.

Note: If MTM is installed on transmission with notch on Rail E facing down, Fault Code/SPN 320/5942 sets Active and transmission does not shift out of neutral.

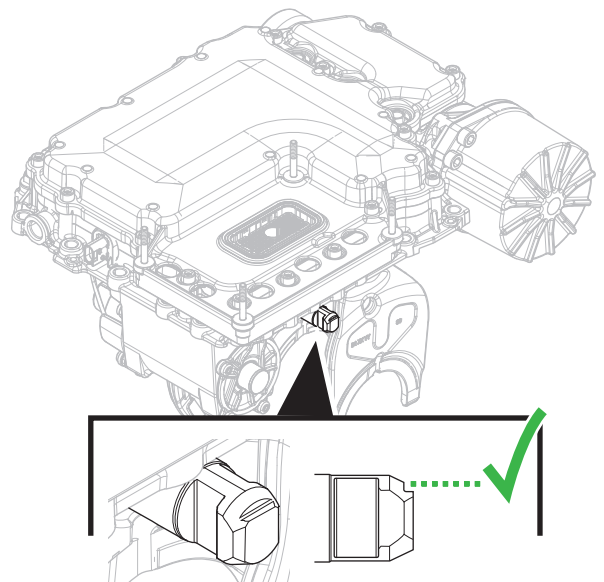

17. Verify Rail E is in neutral using the Fork Side Actuator end of the Confirm-Neutral Gauge (RR1088TR-2) at Shift Rail E. Rail E is in neutral when end of gauge rests against cover with rail against notch-end of gauge.

Note: If Rail E is not in neutral, slide rail in or out until neutral is achieved.



18. Slide O-ring over the MTM front alignment pin on the main housing until fully seated in the groove.

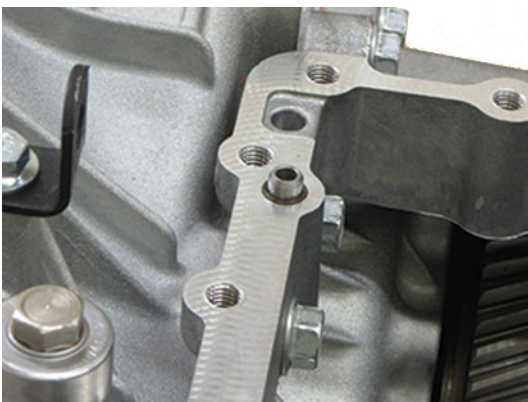

19. Clean the sealing surfaces on the transmission and Mechatronic Transmission Module (MTM) with gasket remover and a plastic scraper. Let air dry then wipe with a clean dry cloth.

NOTICE: Do not use abrasive scrapers or powered tools to clean sealing surfaces or sealing surfaces may be damaged and leak.

20. Apply gasket sealant with a bead width of 1.4-2.4mm (0.055-0.094 inch) to the transmission housing sealing surface following the pattern below.

NOTICE: Ensure there is nothing in the threaded bolt holes or the transmission may be damaged when cap screws are tightened.

Note: Parts must be assembled within 10 minutes of applying Gasket Sealant.

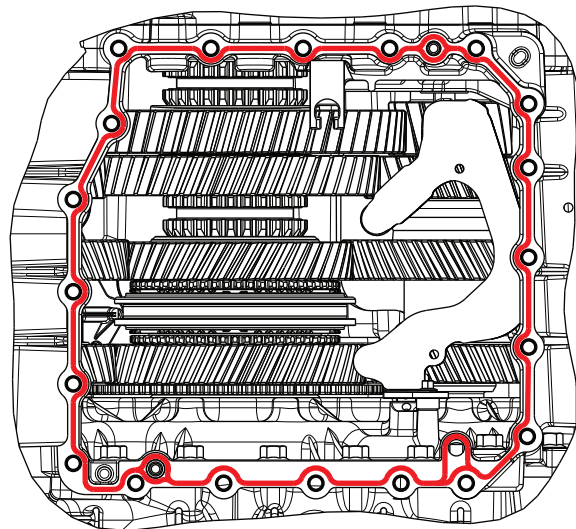

21. Install MTM onto the transmission housing. Align Rail E in the MTM with the Rail E Shift Rail in the Main Housing.

CAUTION: MTM weighs approximately 40 lbs. Keep fingers clear of pinch point between MTM and other surfaces. Dropping MTM could result in component damage and/or personal injury.

NOTICE: If the MTM is installed on the transmission and Rail E in the MTM is not aligned with Rail E in the Main Housing, Fault Code 320 (SPN 5942) sets Active and the transmission will not shift out of neutral.

22. Install 20 MTM cap screws and torque to 44.5-51.5 Nm (33-38 lb-ft) in a criss-cross pattern.

Note: 13 mm (x18), 15 mm (x2) cap screws.

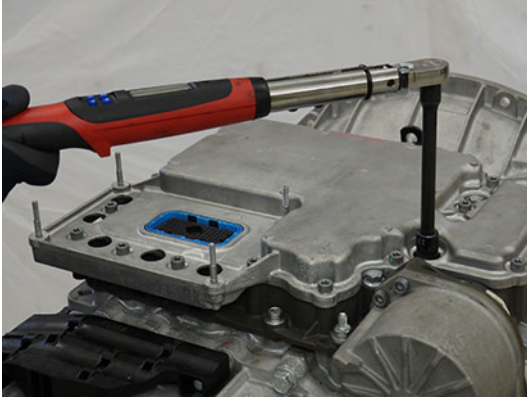

Install the Transmission Control Module (TCM)

NOTICE: Do not allow contamination into the connectors on the TCM or MTM.

Note: TCM can be installed with transmission in-vehicle.

1. Install the TCM Seal on the 74-Way Harness Connector.



2. Align the TCM to the 74-Way Harness Connector and TCM studs, then install the TCM.

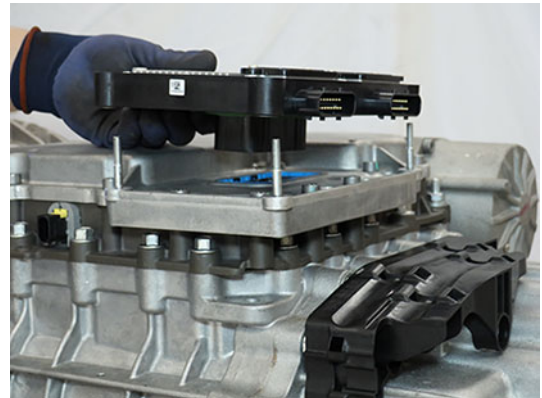

3. Torque the TCM 7 mm Jackscrew to 3.0-4.0 Nm (26.6-35.4 lb-in).

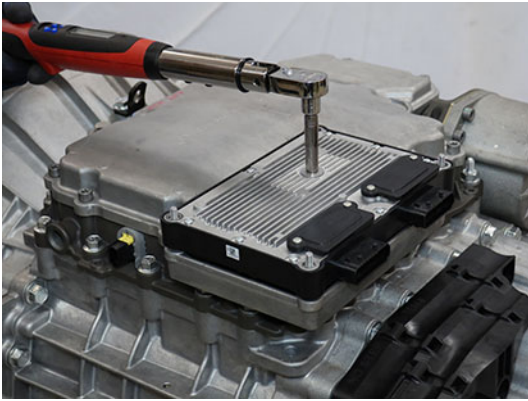

4. Install the TCM Cover over the 4 TCM studs and torque the 4 TCM Cover Nuts to 8.8-10.4 Nm (78-92 lb-in) in a criss-cross pattern.

Note: TCM Cover nuts are 10 or 13 mm.

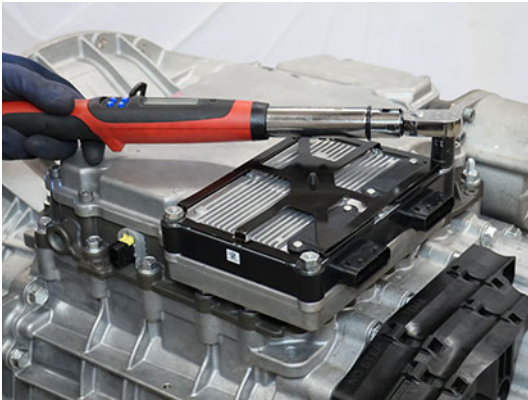

Remove the Linear Clutch Actuator (LCA)

1. Loosen the 4 LCA cap screws 1-2 turns each with a T45 Torx.

NOTICE: Ensure key is off, 20-Way TCM Vehicle and Body Harness Connectors are disconnected, and 5 minutes has passed prior to LCA removal.

Note: Residual air pressure in the LCA cylinder exhausts between the LCA and MTM housing when the cap screws are loosened.



2. Remove the 4 LCA cap screws
3. Remove the LCA from the MTM.

Note: LCA piston rod end is seated in the release yoke socket; pull to release rod end from socket.



- Inspect the plastic socket insert in the release yoke through the LCA opening using a flashlight to verify none of the fingers are missing or damaged.

Note: If the plastic insert is damaged, replace the release yoke assembly.

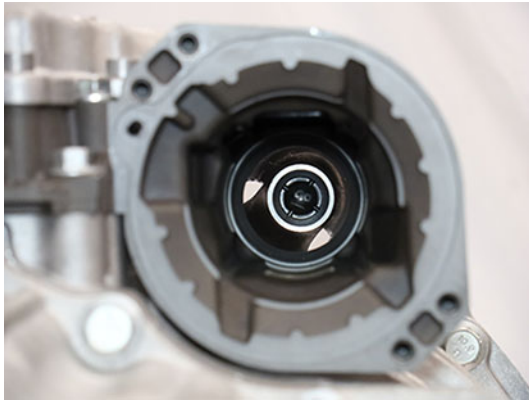

Reset and Install Linear Clutch Actuator (LCA)

- Inspect LCA to determine next steps, reference images below:
 - If LCA is locked in the reset position, go to Install Linear Clutch Actuator (LCA).
 - If LCA is not locked in the reset position, go to Step 2.

Locked in Reset Position

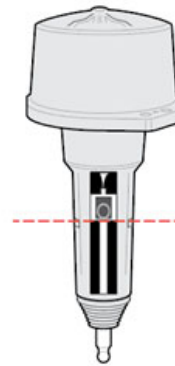

Not Locked in Reset Position

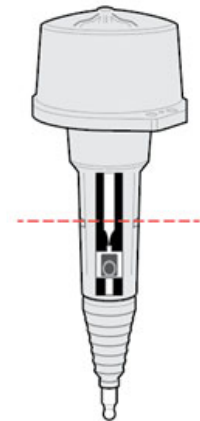

- Place LCA push rod on a clean, flat surface. Tightly grasp LCA housing with both hands and push down on push rod to lock LCA into the reset position.



CAUTION: A large amount of force is required to lock the LCA into the reset position. Failure to tightly grasp the LCA housing with both hands while pushing down on push rod may cause unintended movement resulting in personal injury and/or component damage.



3. Inspect LCA to determine next steps, reference images below:

- If LCA remains locked in the reset position, go to Step 4.
- If LCA does not remain locked in the reset position, go to Step 2, repeat reset procedure.

Note: If LCA cannot be locked into the reset position, replace LCA.



CAUTION: Do not drop LCA. Dropping LCA may cause the LCA to unlock resulting in personal injury and/or component damage.

Locked in Reset Position

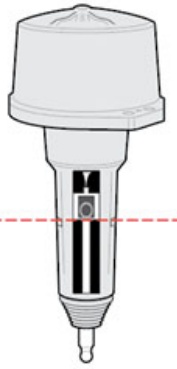

Not Locked in Reset Position

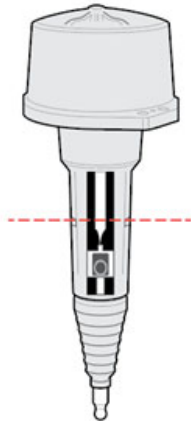

4. Clean all sealing surfaces on the MTM and LCA with a lint free cloth.

NOTICE: Do not use abrasive scrapers or powered tools to clean sealing surfaces or sealing surfaces may be damaged and leak.

5. Insert the LCA into the MTM.



6. Install 4 LCA T45 cap screws and torque to 23-28 Nm (17-21 lb-ft) in a criss-cross pattern.

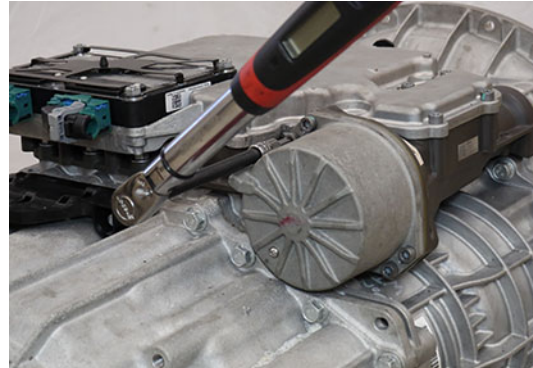

Install the Release Bearing and Clutch Release Yoke

1. Install the upper Release Yoke socket over the rod end of the Linear Clutch Actuator (LCA) and press until attached.



2. Install the lower Release Yoke socket over the lower pivot on the clutch housing and press until attached.



3. Slide the Release Bearing over the input shaft and into the Release Yoke.



Install the Transmission

1. Refer to OEM guidelines for transmission installation.
2. Connect negative battery cable.

Fill Oil

Note: Perform the transmission fill procedure with transmission installed in vehicle to ensure proper transmission angle.

1. Remove the Oil Fill Plug with a 6 mm hex key.

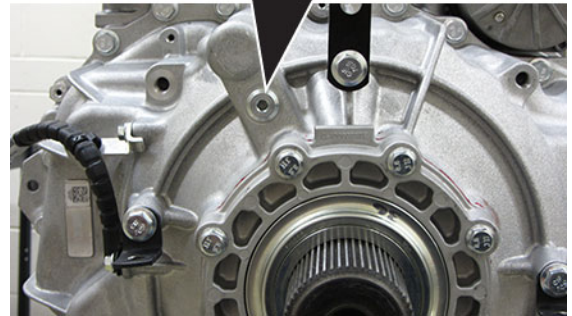

2. Place a suitable container under the Oil Check Plug and remove the Oil Check Plug with a 6 mm hex key.



3. Fill the transmission with PS-386 lube until a small amount of oil runs out of the Oil Check Plug hole.

Note: Fill capacity is approximately 7.5-8.5 liters (16-18 pints) depending on the transmission angle.

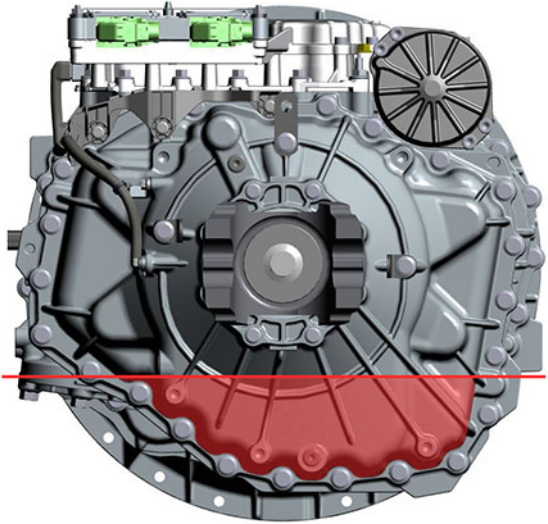
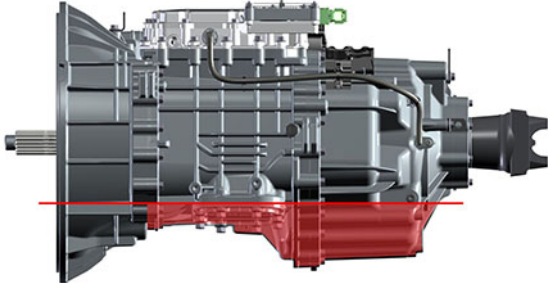

4. Inspect Oil Check Plug and O-ring for damage. If damaged, replace the Oil Check Plug; O-ring is serviced with plug.

5. Install the Oil Check Plug (6 mm) and torque to 24.5-29.5 Nm (18-22 lb-ft).

NOTICE: Do not over-torque the Oil Fill Plug or transmission damage may occur.



6. Inspect Oil Fill Plug and O-ring for damage. If damaged, replace the Oil Fill Plug; O-ring is serviced with plug.

7. Install the Oil Fill Plug (6 mm) and torque to 24.5-29.5 Nm (18-22 lb-ft).

NOTICE: Do not over-torque the Oil Fill Plug or transmission damage may occur.

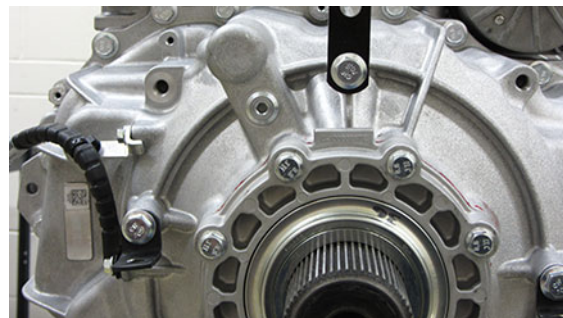

Clutch and Rail Calibration

To ensure proper operation, the TCM, clutch, MTM and transmission require a Clutch and Rail Calibration. Calibrations are automatically initiated when:

- LCA is in the reset position
- Transmission in “N” (Neutral)
- Key on engine running
- Vehicle air system pressure at operating range

NOTICE: Do not use service tool to initiate calibrations. Allow calibrations to automatically initiate.

Note: Vehicle display may indicate a flashing “CC” and “F” in gear display.

1. Set vehicle parking brake and chock wheels.
2. Ensure the driveline is connected between the transmission and axle.

Note: Clutch and Rail Calibrations cannot complete if the transmission output shaft is allowed to rotate.
3. Key on with engine running.
4. Allow vehicle air pressure to build to governor cut-off.

Note: Clutch and Rail Calibrations automatically initiate when vehicle air pressure reaches approximately 100 psi.
5. Ensure “N” (Neutral) is selected and engine is running. Wait approximately 2 minutes for calibrations to complete.

NOTICE: If process is interrupted, key off, wait 1 minute and go to Step 2.

 - If vehicle display indicates a solid “N: (Neutral) in gear display, calibrations are complete. Key off, go to Step 6.
 - If vehicle display continues to indicate a flashing “CC” and/or “F” in gear display or service transmission message, go to Step 5.
6. Key off and wait 1 minute.
7. Key on with engine off.
8. Connect ServiceRanger.



CAUTION: Failure to repeat the Fill Oil service procedure to verify proper transmission oil level when equipped with a PTO may result in low transmission oil and component damage.

9. Go to “Fault Codes”.
 - If an Active transmission fault code is set, go to Endurant HD Troubleshooting Guide TRTS0950 **Diagnostic Procedure**.
 - If no Active transmission fault codes are set, select “Clear Eaton Faults” and follow on-screen prompts. Go to Step 9.
10. Disconnect ServiceRanger.
11. Key off.
12. Inspect transmission for a PTO.
 - If not PTO-equipped, process complete.
 - If PTO-equipped, start the engine and run for 1 to 2 minutes to fill the PTO with oil, key off and repeat the Fill Oil Procedure.

New Replacement Transmission Control Module (TCM) Service Procedure

Special Instructions

- This procedure is only performed when installing a new replacement TCM.
- Connect ServiceRanger and create a Service Activity Report prior to performing service procedure.
- Complete this entire procedure to ensure proper transmission operation after TCM installation.

Note: If reinstalling original equipment TCM, go to “Transmission Control Module (TCM)” on page 16.

Special Tools

- ServiceRanger

Component Identification

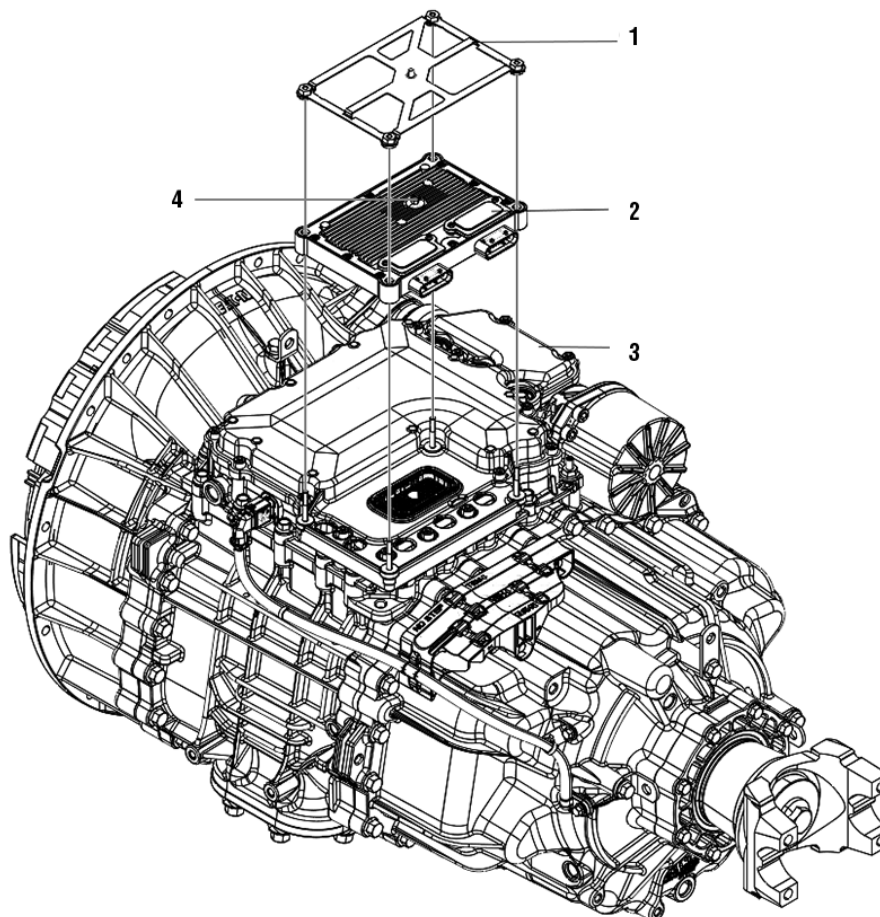

1. Transmission Control Module (TCM) Cover - 10 or 13 mm Nuts
2. Transmission Control Module (TCM)
3. Mechatronic Transmission Module (MTM)
4. Transmission Control Module (TCM) Jackscrew - 7 mm

Vehicle Setup

1. Park vehicle on level ground.
2. Apply vehicle parking brake and chock wheels.



WARNING: Apply vehicle parking brake and follow vehicle manufacturer parking instructions. Failure to follow these instructions could cause unintended vehicle movement and may result in major vehicle component damage, severe injury or death.

Create a Service Activity Report

1. Key on with engine off.
2. Connect ServiceRanger and create a Service Activity Report.
3. Select “Send to Eaton” (internet connection required)
4. Disconnect ServiceRanger.
5. Key off.

Note: If a Service Activity Report or TCM configuration template could not be created on the original equipment TCM, continue with TCM removal and installation.

Create Configuration Template

1. Key on with engine off.
2. Connect ServiceRanger.
3. Go To Configuration.
4. Select “Save a new configuration template” icon.

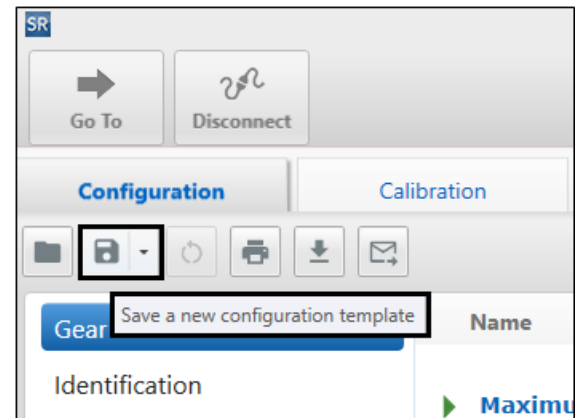

5. Select “Save Current Values”.

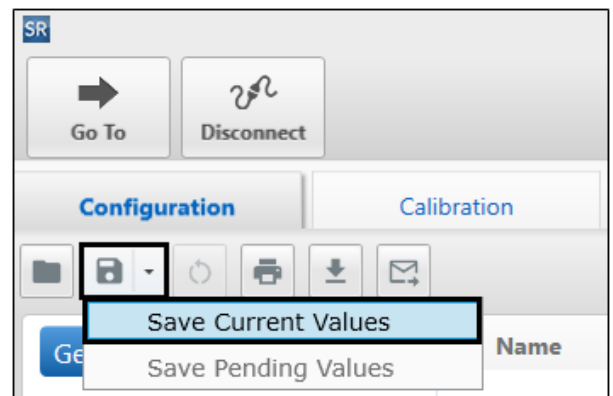

6. Enter repair order number, last 6 digits of VIN and select "Save".

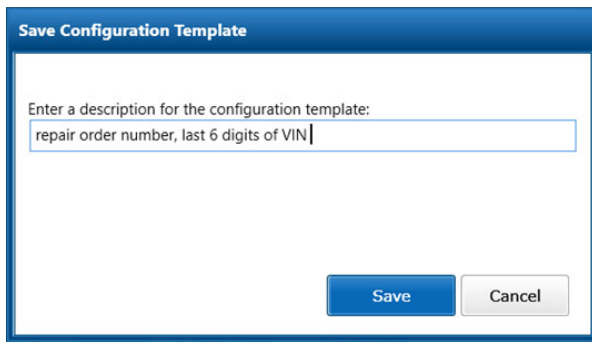

Save Configuration Template

Enter a description for the configuration template:

repair order number, last 6 digits of VIN

Save Cancel

7. Disconnect ServiceRanger.
8. Key off.

Disconnect the Transmission Control Module (TCM)

1. Disconnect the negative battery cable.

NOTICE: Leaving battery cable connected may damage TCM.

2. Disconnect the 20-Way TCM Vehicle and Body Harness Connectors from the TCM by pressing the lever into the locked position.

NOTICE: Do not allow contamination into the connectors on the TCM.



Remove the Transmission Control Module (TCM)

1. Unscrew the 4 TCM Cover nuts and remove TCM Cover.

Note: TCM Cover nuts are 10 or 13 mm.



2. Unscrew the TCM 7 mm Jackscrew. Lift and remove the TCM from the MTM.

NOTICE: Do not allow contamination into the connectors on the TCM or MTM.



3. Inspect the TCM Seal for damage.

NOTICE: Replace the TCM Seal if damaged.

Note: If replacing the TCM, the REMAN TCM includes a new seal.



Install the Transmission Control Module (TCM)

NOTICE: Do not allow contamination into the connectors on the TCM or MTM.

Note: TCM can be installed with transmission in-vehicle.

1. Install the TCM Seal on the 74-Way Harness Connector.



2. Align the TCM to the 74-Way Harness Connector and TCM studs, then install the TCM.

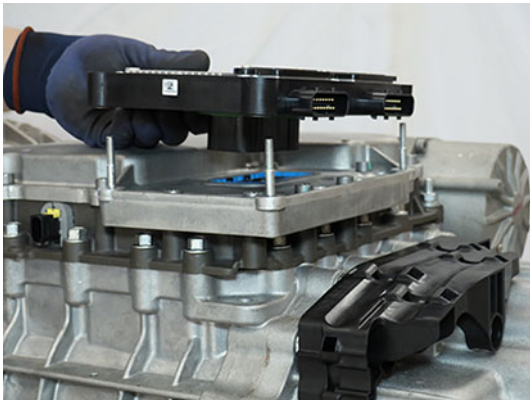

3. Torque the TCM 7 mm Jackscrew to 3.0-4.0 Nm (26.6-35.4 lb-in).

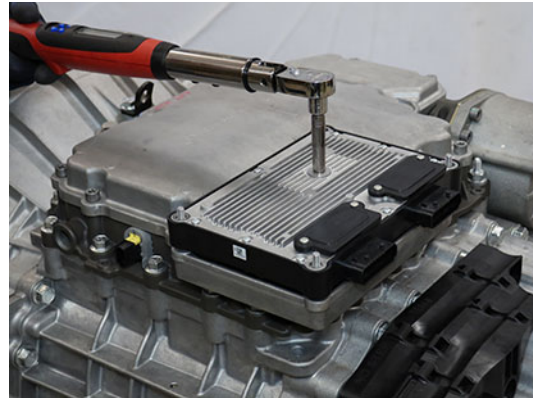

4. Install the TCM Cover over the 4 TCM studs and torque the 4 TCM Cover Nuts to 8.8-10.4 Nm (78-92 lb-in) in a criss-cross pattern.

Note: TCM Cover nuts are 10 or 13 mm.

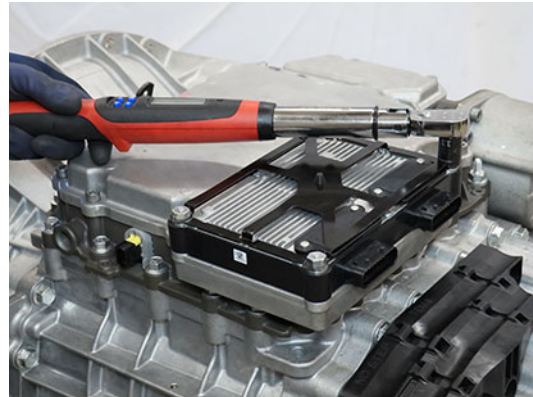

Connect the Transmission Control Module (TCM).

1. Connect both 20-Way TCM Vehicle and Body Harness Connectors to the TCM by pressing the lever into the locked position.

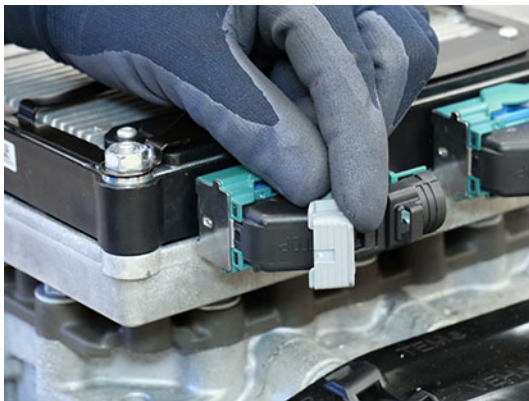

2. Connect the negative battery cable.

Configure Transmission Control Module (TCM)

Enter current transmission serial number and MTM serial number into TCM.

1. Record transmission serial number.

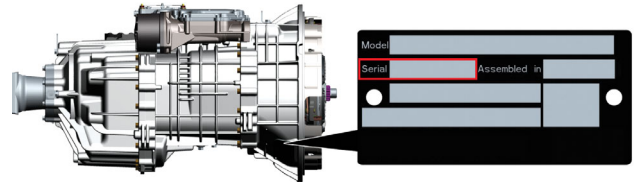

2. Record MTM serial number.

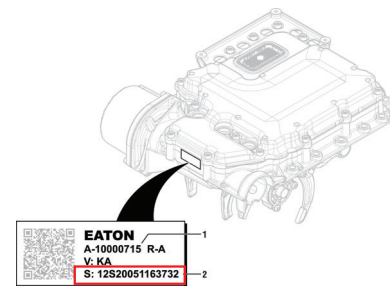

3. Key on with engine off.

Note: Vehicle display may indicate a flashing “F”, “CC”, or service transmission.

4. Connect ServiceRanger.
5. Go To “Configuration”.
6. Select “Identification”.
7. In the “Serial Number” parameter “New Value” field enter transmission serial number.

- In the “Current MTM Serial Number” parameter “New Value” field enter MTM serial number.

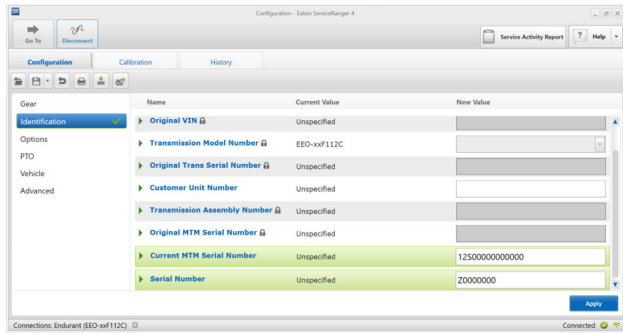

- Select “Apply” and follow on-screen prompts.

Install Configuration Template into New Replacement TCM

Note: If a Service Activity Report or TCM configuration template could not be created on the original equipment TCM, contact Eaton Cummins Automated Transmission Technologies for further diagnostic instructions:

- U.S. and Canada Help Line: +1-800-826-4357
- Mexico Help Line: +52-800-800-6801

- Key on with engine off.
- Connect ServiceRanger.
- Go To Configuration.
- Select “Open a configuration template” icon:

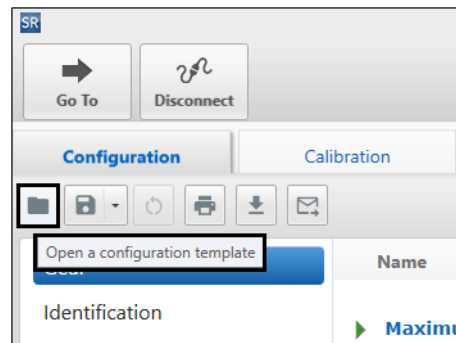

- Select “Saved” tab.

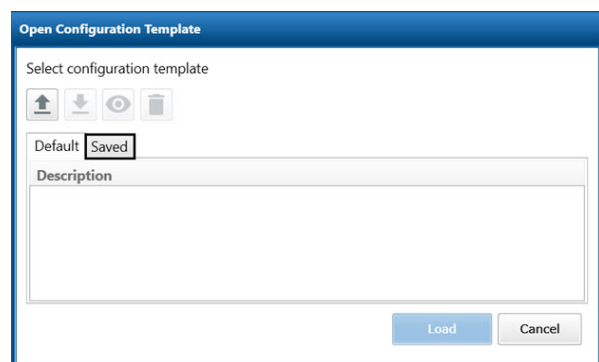

6. Select configuration template created at the beginning of this procedure (repair order number, last 6 digits of VIN).

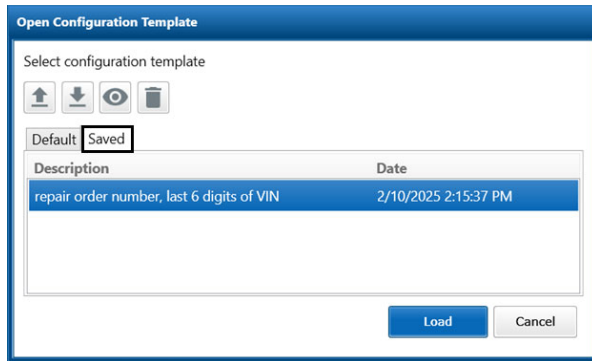

7. Select "Load".
8. Select "Apply" (lower right corner) and follow on-screen prompts.

Configure Engine Calibration

Engine may not crank due to engine calibration not configured in TCM. Engine calibration is specific to vehicle make, engine model, and engine EPA model year(s).

1. Key on with engine off.
2. Connect ServiceRanger.
3. Go To "Configuration".
4. Select "Calibration" tab.
5. Record status of Base Calibration.
 - If "Your calibration is up-to-date", go to "Perform Grade Sensor Calibration" on page 543.
 - If "Your calibration is out-of-date", contact Eaton Cummins Automated Transmission Technologies for further diagnostic instructions:
 - U.S. and Canada Help Line: +1-800-826-4357
 - Mexico Help Line: +52-800-800-6801

Perform Grade Sensor Calibration

1. Key on with engine off.
2. Connect ServiceRanger.
3. Go To “Service Routines”.
4. Select “Start” Grade Sensor Calibration and follow on-screen prompts.

Clutch and Rail Calibrations - Automatically Initiated

To ensure proper transmission operation after TCM installation, TCM, MTM, and clutch transmission need to be calibrated. Calibrations automatically initiate after vehicle air system pressure reaches operating range (approximately 100 psi).

1. Key on with engine running.
2. Allow vehicle air pressure to build to governor cut-off.

Note: Clutch and Rail Calibrations automatically initiate when vehicle air pressure reaches approximately 100 psi.

3. Ensure “N” (Neutral) is selected and engine is running. Wait for approximately 2 minutes for calibrations to complete.

NOTICE: If process is interrupted, key off, wait 1 minute, go to **Step 1**.

- If vehicle display indicates a solid “N” (Neutral) in gear display, calibrations are complete. Key off, go to **Step 5**.
- If vehicle display continues to indicate a flashing “CC” and/or “F” in gear display or service transmission message, go to **Step 4**.

4. Key off and wait 1 minute.
5. Key on with engine off.
6. Connect ServiceRanger.
7. Go to “Fault Codes”.
 - If an Active transmission fault code is set, go to Endurant HD Troubleshooting Guide TRTS0950 **Diagnostic Procedure**.
 - If NO Active fault codes set, select “Clear Eaton Faults” and follow on-screen prompts.
8. Disconnect ServiceRanger.
9. Key off.
10. Process complete.

Primary Drive Gear Replacement

Special Instructions

This procedure provides instructions for replacing the Primary Drive Gear and Rail C Sliding Clutch.

- Primary Drive Gear (S-3206)
- Rail C Sliding Clutch (10000557)
- I-Brake MTM to Main Housing O-ring (13653)
- I-Brake Main Housing to Clutch Housing O-ring (13834)

Special Tools

- Rear Housing Alignment Pins (RR1090TR)
- Upper Countershaft Pilot Tool (RR1071TR)
- Lower Countershaft Pilot Tool (RR1072TR)
- Mechanical Diagnostic Kit (RR2011TR)
- Gasket Sealant (Loctite 5188)
- Transmission Assembly Lube (Lubegard® Assemblee Goo Firm Tack - Green #19250 or equivalent)
- Plastic Scraper
- Gasket Remover (Non-Chlorinated Brake Cleaner)



DANGER: Do not handle non-chlorinated brake cleaner until all manufacturer precautions have been read and understood. Failure to follow precautions will result in serious personal injury or death.



CAUTION: Avoid contact between non-chlorinated brake cleaner and the transmission plastic components, electrical wiring and connectors. Failure to avoid contact will result in transmission component damage.

Component Identification

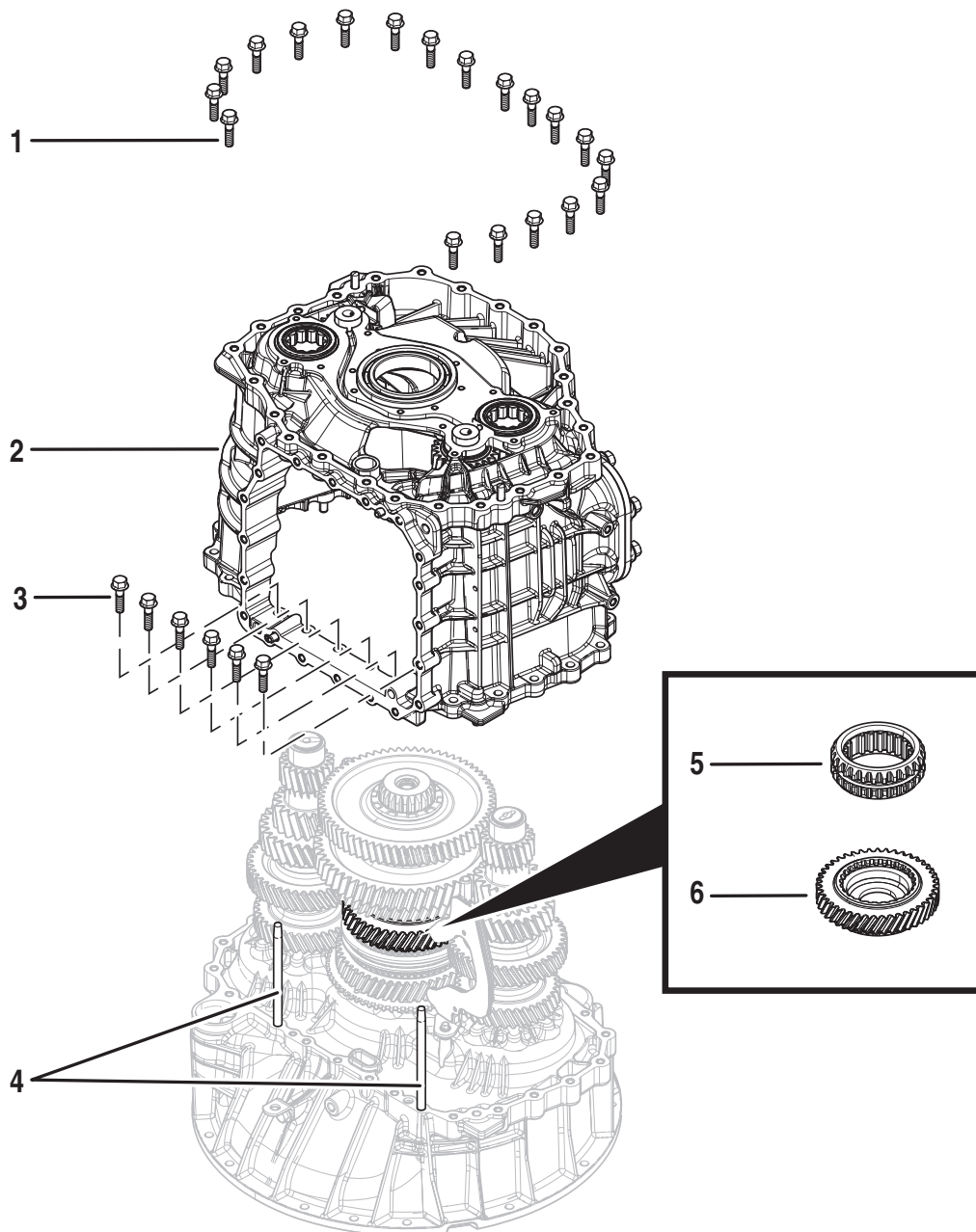

- 1. Main Housing External Cap Screws (x19) - 16 mm
- 2. Main Housing
- 3. Main Housing Internal Cap Screws (x6) - 16mm

- 4. Rear Housing Alignment Pins (RR 1090TR)
- 5. Rail C Sliding Clutch
- 6. Primary Drive Gear

Create a Service Activity Report

Note: If not already created and sent.

1. Key on with engine off.
2. Connect ServiceRanger and create a Service Activity Report.
3. Select "Send to Eaton" (internet connection required)
4. Disconnect ServiceRanger.
5. Key off.

Drain Oil

1. Locate the Oil Drain Plug on the back of the rear housing.
2. Place a suitable container under the Oil Drain Plug.

Note: If reusing oil, use a clean container free of contamination and debris.
3. Remove the Oil Drain Plug with a 6 mm hex key and drain the oil.

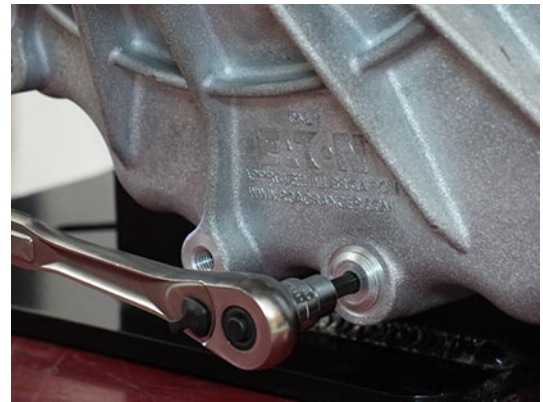

4. If PTO-equipped, remove PTO and drain the oil.
5. Inspect Oil Drain Plug and O-ring for damage. If damaged, replace the Oil Drain Plug; O-ring is serviced with plug.
6. Install the Oil Drain Plug (6 mm) and torque to 24.5-29.5 Nm (18-22 lb-ft).

NOTICE: Do not over-torque drain plug or transmission damage may occur.

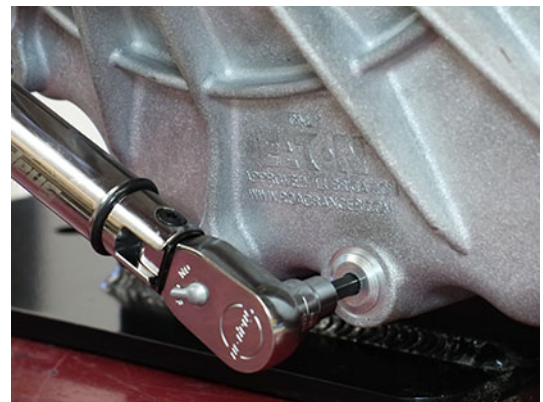

Manually Vent Linear Clutch Actuator (LCA)

1. Key off.
2. Set vehicle parking brake and chock wheels.

! **WARNING:** Apply vehicle parking brake and follow vehicle manufacture parking instructions. Failure to follow these instructions could cause unintended vehicle movement and may result in major vehicle component damage, severe injury or death.

3. Loosen the 4 Linear Clutch Actuator (LCA) cap screws 1-2 turns each with a T45 Torx.

Note: Residual air pressure in the LCA cylinder exhausts between the LCA and Mechatronic Transmission Module (MTM) housing when the cap screws are loosened.

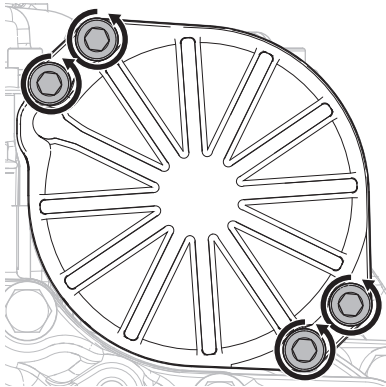

4. Tighten the 4 LCA to MTM T45 cap screws and torque to 23-27 Nm (17-21 lb-ft).

Remove Transmission

1. Disconnect negative battery cable.
2. Refer to OEM guidelines for transmission removal.

Remove Release Bearing and Clutch Release Yoke

1. Remove the Release Bearing by sliding the bearing off the input shaft.

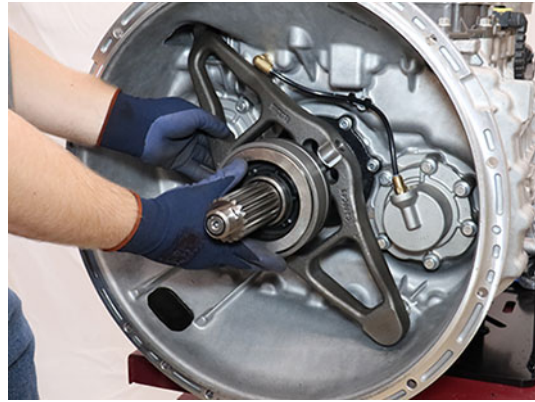

2. Pull to free the lower Clutch Release Yoke socket from the lower pivot on the clutch housing.

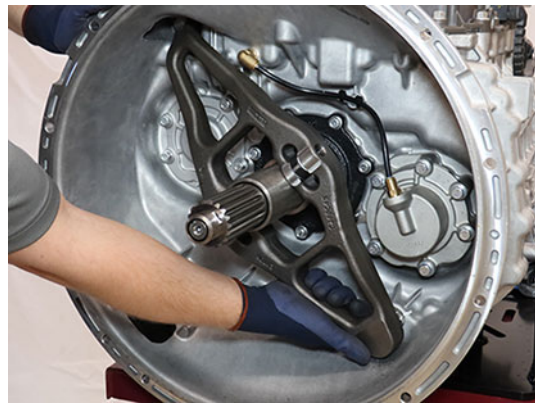

3. Pull to free the upper Clutch Release Yoke socket from the Linear Clutch Actuator (LCA) rod end.



4. Inspect the plastic socket inserts in the Clutch Release Yoke to verify none of the fingers are missing or damaged.

Note: If the plastic insert is damaged, replace the Clutch Release Yoke Assembly and the Release Yoke Pivot Pin.



Remove Transmission Control Module (TCM)

1. Unscrew the 4 TCM Cover nuts and remove TCM Cover.

Note: TCM Cover nuts are 10 or 13 mm.



2. Unscrew the TCM 7 mm Jackscrew. Lift and remove the TCM from the MTM.

NOTICE: Do not allow contamination into the connectors on the TCM or MTM.



3. Inspect the TCM Seal for damage.

NOTICE: Replace the TCM Seal if damaged.



Remove Mechatronic Transmission Module (MTM)

1. Lift the latch on the Output Speed Sensor Harness at the Connector on the Mechatronic Transmission Module (MTM).



2. Remove the Output Speed Sensor Harness from the Connector on the MTM.



3. Remove the 20 MTM cap screws.

Note: 13 mm (x18), 15 mm (x2).

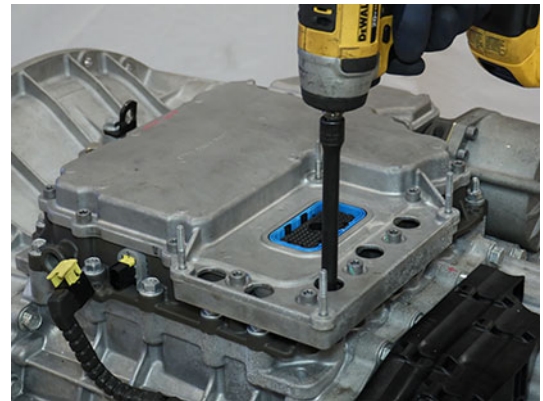

4. Separate the MTM from the Main Housing at the 2 pry points.

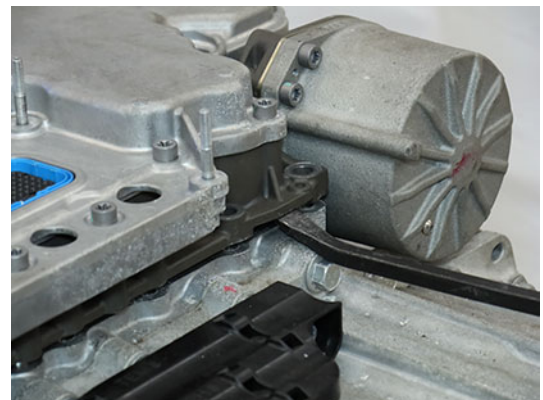

5. Remove the MTM from the transmission housing.

⚠ CAUTION: MTM weighs approximately 40 lbs. Keep fingers clear of pinch point between MTM and other surfaces. Dropping MTM could result in component damage and/or personal injury.



Remove Output Speed Sensor

1. Remove the Output Speed Sensor Harness tie strap at the Harness Bracket.



2. Remove the 2 harness press-in retainers from the Main Housing and bracket on Rear Housing.



3. Remove the Output Speed Sensor 10 mm cap screw.



4. Remove the Output Speed Sensor from the Rear Housing.

Note: The sensor may need to be twisted and pulled from the bore.



Remove Harness Bracket

1. Remove the Output Speed Sensor Harness tie strap at the Harness Bracket.



2. Remove 3 Harness Bracket 10 mm cap screws.



3. Remove Harness Bracket.



Secure Transmission (Vertical)

1. Place transmission in the vertical position with the front side down.



WARNING: Transmission weighs approximately 550 lbs. Keep fingers clear of pinch point between transmission and other surfaces. Dropping transmission may result in major vehicle component damage, severe injury or death.

NOTICE: Use an appropriate lifting device to safely lift component.

Note: Use a surface with an opening that allows the input shaft to pass through and the clutch housing to sit flat and secure.

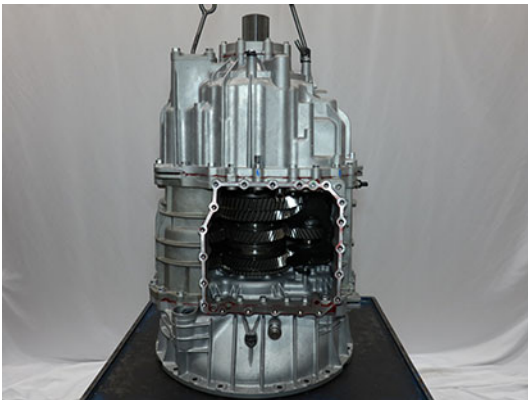
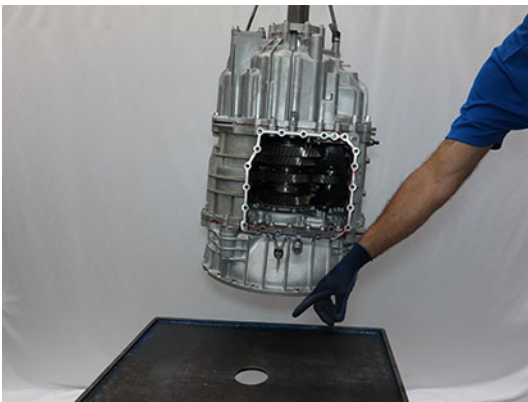

Remove Rear Housing

1. At the 3 Rear Housing Threaded cap screws, apply paint marks on the Rear Housing to identify location.



2. Remove 21 Rear Housing and 3 threaded 16 mm cap screws.



3. Install and hand tighten 2 Rear Housing Alignment Pins (RR1090TR) 180-degrees apart.

NOTICE: Failure to install alignment pins results in transmission component damage.



4. Separate the Rear Housing from the Main Housing at the 2 pry points.



5. Lift and remove Rear Housing Assembly from Main Housing.



WARNING: Rear Housing Assembly weighs approximately 170 lbs. Failure to properly secure and lift the Rear Housing Assembly may result in major vehicle component damage, severe injury or death.

NOTICE: Use an appropriate lifting device to safely lift component.

Note: Dual PTO Transmissions are equipped with a rear PTO lube tube port on the pump and rear PTO drive splines on the Upper Countershaft.

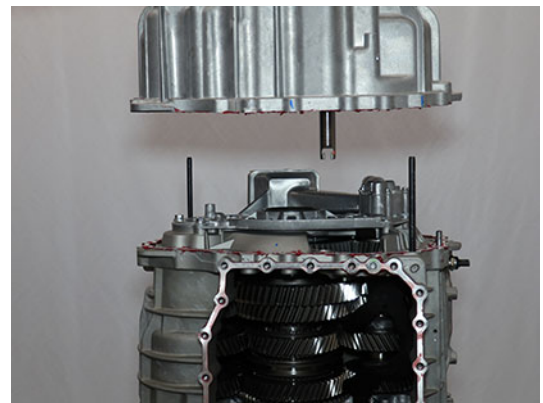

- Place Rear Housing Assembly on bench.



WARNING: Rear Housing Assembly weighs approximately 170 lbs. Keep fingers clear of pinch point between Rear Housing Assembly and other surfaces. Dropping Rear Housing may result in major vehicle component damage, severe injury or death.

NOTICE: Support the Rear Housing Assembly to prevent damage to Shift Rail E.

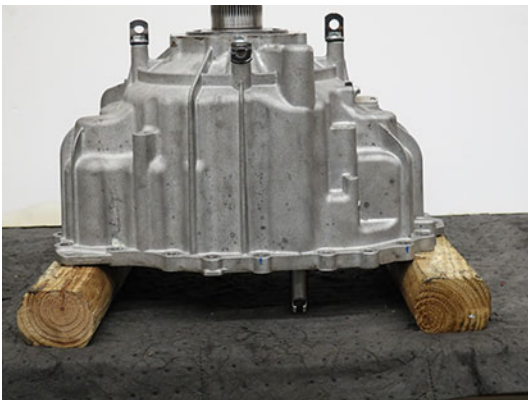

- Remove the 2 Rear Housing Alignment Pins (RR1090TR) from the Main Housing.

Remove Oil Pump Assembly

- Remove 18 Oil Pump Assembly 13 mm cap screws.



- Remove Oil Pump Assembly.



- Remove Oil Pump/Range Spacer with O-ring.



Remove Main Housing

1. Remove the 19 external and 6 internal Main Housing 16 mm cap screws.

NOTICE: To avoid internal transmission contamination, keep internal and external Main Housing cap screws separated.



2. Install and hand tighten 2 Rear Housing Alignment Pins (RR1090TR) in the internal Main Housing cap screw outer threaded holes.

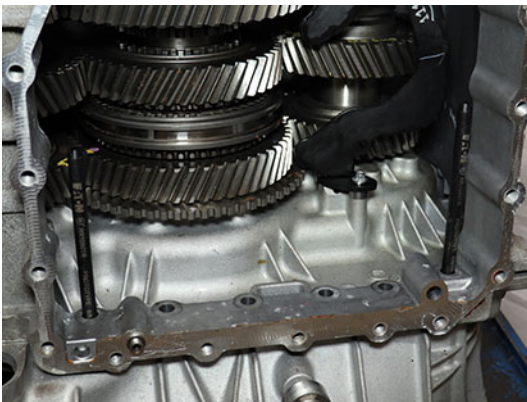

3. Remove 2 Rear Housing 90-degree Lifting Eye 15 mm cap screws from Rear Housing.

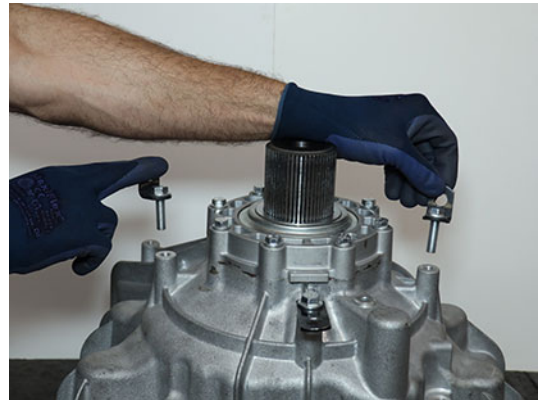

4. Install and hand tighten 2 Rear Housing 90-degree Lifting Eyes and 15 mm cap screws to Main Housing.

NOTICE: Do not over tighten cap screws.

Note: Install 90-degree Lifting Eyes 180-degrees apart to ensure even lifting.

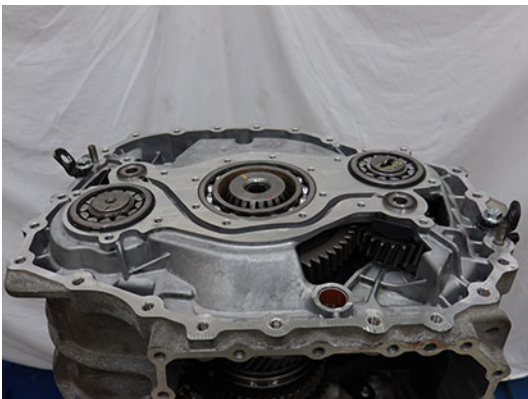

5. Separate Main Housing from Clutch Housing at the 2 pry points.



6. Lift and remove Main Housing from Clutch Housing.



CAUTION: Main Housing weighs approximately 50 lbs. Keep fingers clear of pinch point between Main Housing and other surfaces. Dropping Main Housing could result in component damage and/or personal injury.

NOTICE: Use an appropriate lifting device to safely lift component.

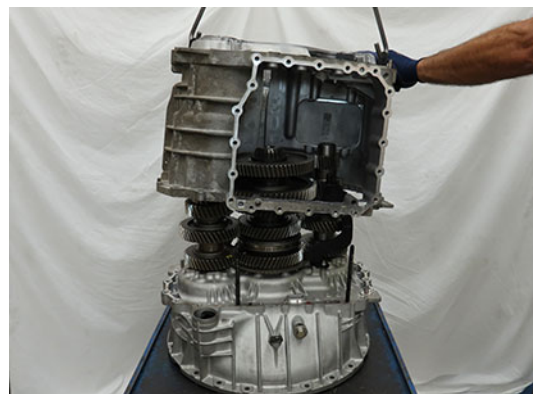

Remove Main Shaft and Countershaft

1. Install a magnet onto Main Shaft Key to ensure the key stays in place during Main Shaft Removal and Installation.



2. Hold Rail C Sliding Clutch against Secondary Driven Gear and lift Main Shaft from Primary Drive Gear.

⚠ CAUTION: Main Shaft weighs approximately 35 lbs. Keep fingers clear of pinch point between Main Shaft and other surfaces. Dropping Main Shaft could result in component damage and/or personal injury.

Note: Spring and Washer may remain attached to the Main Shaft during removal.



3. Remove Wave Spring - Rear.

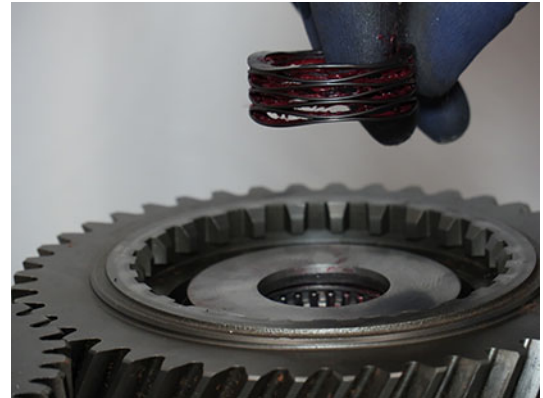

4. Remove Thrust Washer - Rear.



5. Remove Thrust Bearing - Rear.



6. Remove Needle Bearing - Rear.



7. Remove Bearing Race - Rear.



8. Remove Primary Drive Gear.



Install Primary Drive Gear

1. Install new Primary Drive Gear onto Rail B Synchronizer.



2. Install Bearing Race - Rear.



3. Install Needle Bearing - Rear.



4. Install Thrust Bearing - Rear.



Remove Rail C Sliding Clutch

1. Place Main Shaft Assembly horizontally on a clean flat surface.



CAUTION: Secure Main Shaft Assembly while on flat surface to avoid unexpected movement. Failure to properly secure Main Shaft Assembly could result in component damage and/or personal injury.

2. If necessary, remove Thrust Washer - Rear and Wave Spring - Rear.
3. Remove Rail C Sliding Clutch.

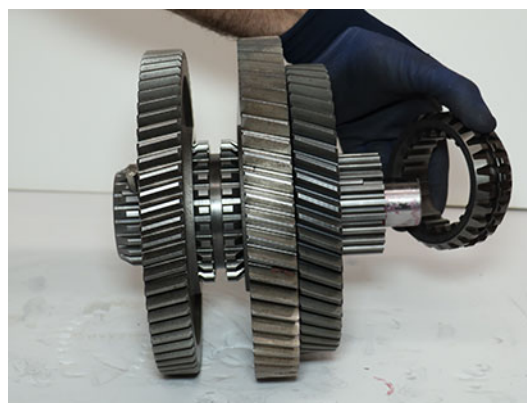

Install Rail C Sliding Clutch

1. Install new Rail C Sliding Clutch and align the double slot with Main Shaft Key.

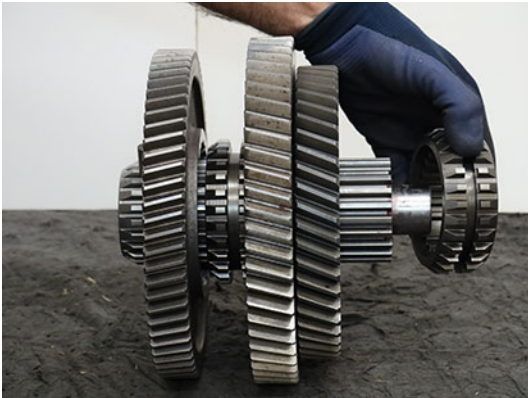
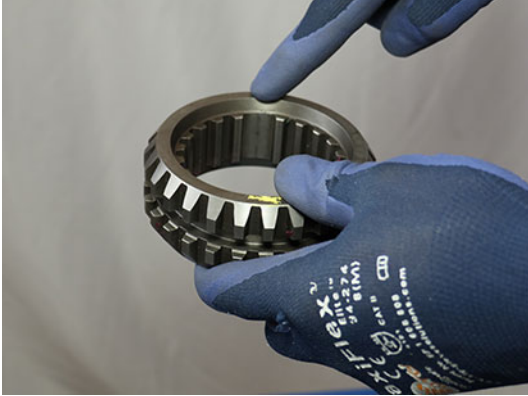

2. Apply transmission assembly lube to Wave Spring - Rear and install to Main Shaft.

NOTICE: Wave Spring - Rear is shorter than the Wave Spring - Front.

Note: Transmission assembly lube holds Wave Spring - Rear in place during Main Shaft Assembly installation.

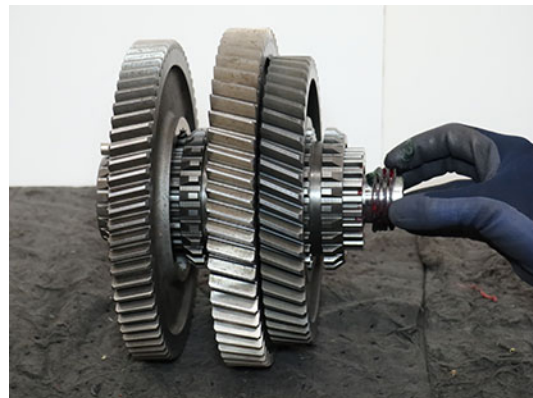

3. Apply transmission assembly lube to Thrust Washer - Rear and install to Main Shaft.

Note: Transmission assembly lube holds Thrust Washer - Rear in place during Main Shaft Assembly installation.



4. Install a magnet onto the Main Shaft Key.

Note: The magnet holds the key in position during Main Shaft Assembly installation.



5. Slide and hold Rail C Sliding Clutch into Secondary Driven Gear.



6. Install Main Shaft Assembly onto Primary Drive Gear and align gearing.



CAUTION: Main Shaft weighs approximately 35 lbs. Keep fingers clear of pinch point between Main Shaft and other surfaces. Dropping Main Shaft could result in component damage and/or personal injury.



7. Remove magnet from Main Shaft Key.

NOTICE: Ensure to remove magnet or component damage may occur during assembly.



Install Main Housing

1. Clean the sealing surfaces on the Clutch Housing and Main Housing with gasket remover and a plastic scraper. Let air dry then wipe with a clean dry cloth.

NOTICE: Do not use abrasive scrapers or powered tools to clean sealing surfaces or sealing surfaces may be damaged and leak.

2. Inspect threaded bolt holes for debris and clean if necessary.

NOTICE: Ensure there is nothing in the threaded bolt holes or the transmission may be damaged when cap screws are tightened.

3. Slide new I-Brake Main Housing to Clutch Housing O-ring (13834) over the Clutch Housing Inertia Brake air passage alignment pin until fully seated in groove.



4. Apply Gasket Sealant with a bead width of 1.4-2.4 mm (0.055-0.094 inch) to clutch housing as shown in pattern below.

NOTICE: Ensure there is nothing in the threaded bolt holes or the transmission may be damaged when cap screws are tightened.

Note: Parts must be assembled within 10 minutes of applying Gasket Sealant.

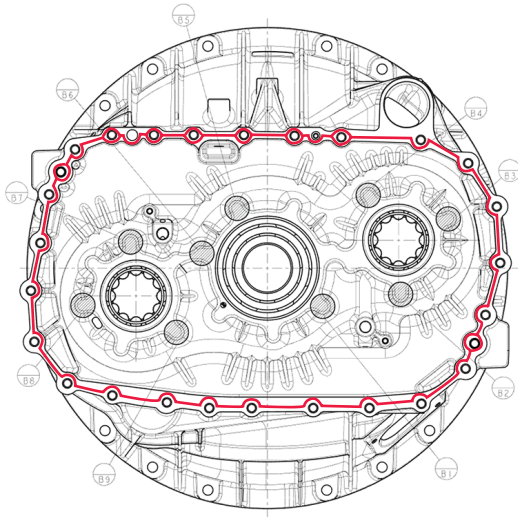

5. Install Lower Countershaft Pilot Tool (RR1071TR) onto Lower Countershaft above rear bearing race.



6. Install Upper Countershaft Pilot Tool (RR1072TR) onto the Upper Countershaft above rear bearing race.



7. Install and hand tighten 2 Rear Housing 90-degree Lifting Eyes and 15 mm cap screws to Main Housing.

NOTICE: Do not over tighten Lifting Eye cap screws.

Note: Install 90-degree Lifting Eyes 180-degrees apart to ensure even lifting.



8. Install and hand tighten 2 Rear Housing Alignment Pins (RR1090TR) into the Clutch Housing as shown below.

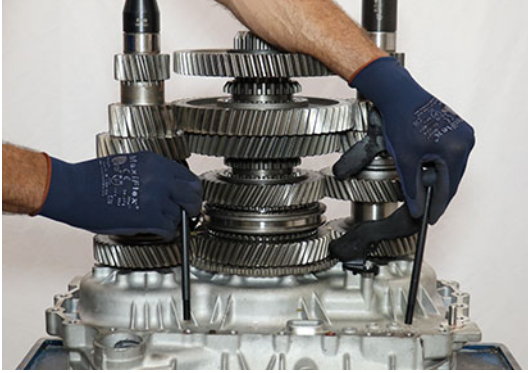

9. Lift, align and install Main Housing to Clutch Housing.



CAUTION: Main Housing weighs approximately 50 lbs. Keep fingers clear of pinch point between Main Housing and other surfaces. Dropping Main Housing could result in component damage and/or serious injury.

NOTICE: Use an appropriate lifting device to safely lift component.

Note: Using a flat tipped screwdriver, rotate the Reverse Idler Gears to align the gearing and allow Main Housing to fully seat onto the Clutch Housing.



10. Remove 2 Rear Housing Alignment Pins (RR1090TR).



11. Remove 2 Rear Housing 90-degree Lifting Eyes and 15 mm cap screws from Main Housing.

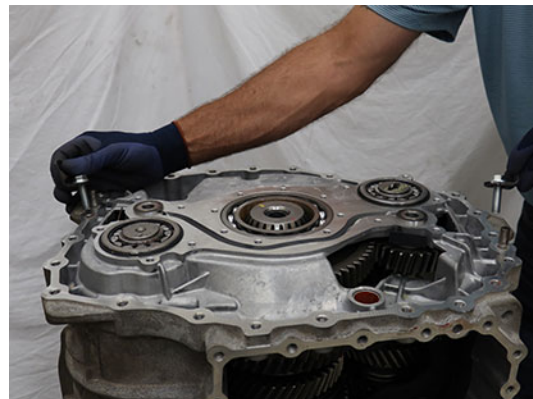

12. Re-install 2 Rear Housing 90-degree Lifting Eyes to the Rear Housing and torque to 49.6-55.5 Nm (36-40 lb-ft).



13. Install 19 external and 6 internal Main Housing 16 mm cap screws and torque to 44-51 Nm (33-38 lb-ft) in a criss-cross pattern.

NOTICE: To avoid internal transmission contamination, keep internal and external Main Housing cap screws separated.

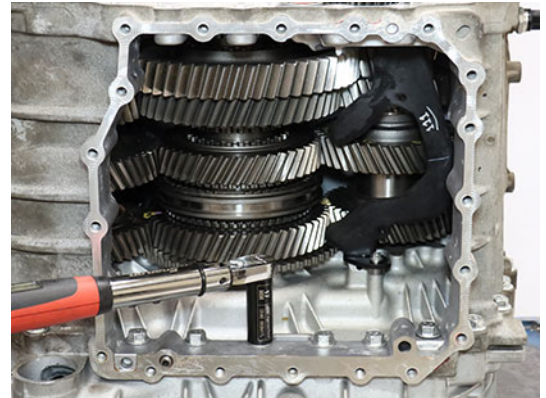

Install Oil Pump Assembly

1. Install O-ring to the Oil Pump/Range Spacer.



2. Install Oil Pump/Range Spacer with O-ring and align tab with groove in Oil Pump Assembly.

NOTICE: Ensure the spacer tab is aligned with the groove and the spacer sits flush in the Oil Pump Assembly.



3. While holding the Oil Pump/Range Spacer in place, align oil pump drive key with slot on Lower Counter-shaft and install Oil Pump Assembly to Main Housing.



CAUTION: Failure to properly install the Oil Pump/Range Spacer and align the oil pump drive key results in transmission component damage during Oil Pump Assembly installation.

NOTICE: Ensure oil pump drive key is aligned with counter shaft drive slot during Oil Pump Assembly installation.



4. Press Oil Pump Assembly to ensure it sits flat on Main Housing sealing surface.



5. Install 18 Oil Pump Assembly 13 mm cap screws and torque to 21–23 Nm (16–18 lb–ft) in a criss-cross pattern.

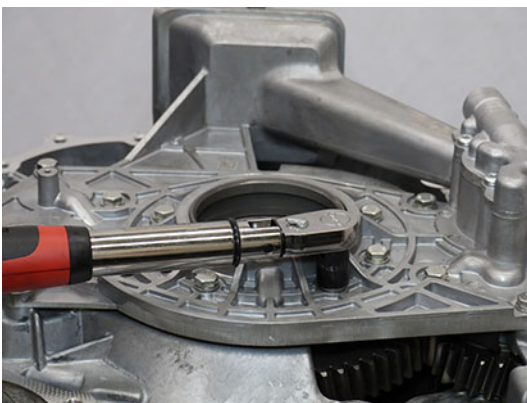
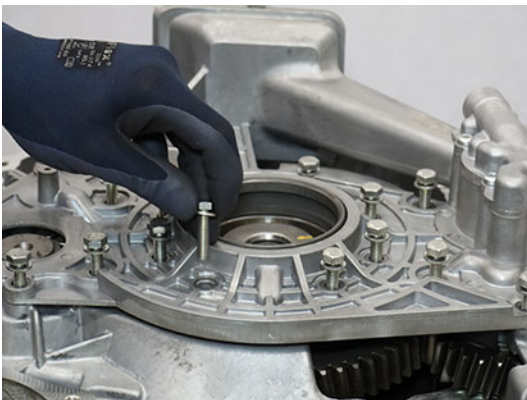

Install Rear Housing

1. Clean the sealing surfaces on the transmission Main Housing and Rear Housing with gasket remover and a plastic scraper. Let air dry then wipe with a clean dry cloth.

NOTICE: Do not use abrasive scrapers or powered tools to clean sealing surfaces or sealing surfaces may be damaged and leak.

2. Inspect threaded bolt holes for debris and clean if necessary.
3. Apply Gasket Sealant with a bead width of 1.4-2.4 mm (0.055-0.094 inch) to the transmission Main Housing sealing surface following the pattern below.

NOTICE: Ensure there is nothing in the threaded bolt holes or the transmission housing may be damaged when cap screws are tightened.

Note: Parts must be assembled within 10 minutes of applying Gasket Sealant.

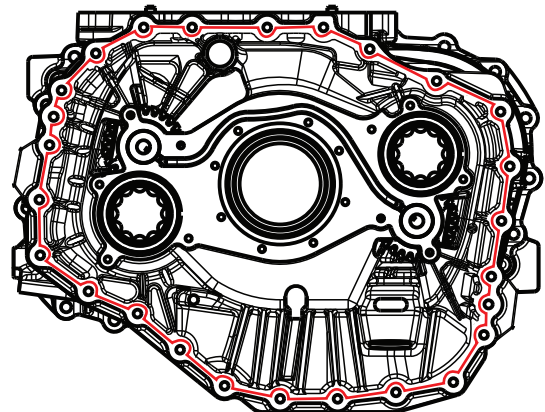

4. Install and hand tighten 2 Rear Housing Alignment Pins (RR1090TR) 180-degrees apart.



CAUTION: Failure to install alignment pins results in transmission component damage during Rear Housing Assembly installation.

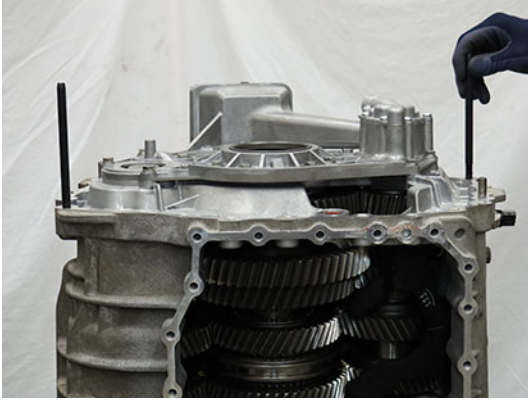

6. Install the 3 Rear Housing Threaded 16 mm cap screws at the 3 paint mark locations.

Note: Two cap screws are used to mount the harness bracket and the third is used by the OEM for additional attachment points.



5. Lift and install the Rear Housing Assembly on to the Main Housing.



WARNING: Rear Housing Assembly weighs approximately 170 lbs. Failure to properly secure and lift the Rear Housing may result in major vehicle component damage, severe injury or death.

NOTICE: Use an appropriate lifting device to safely lift component.

Note: Align the Rear Housing to the alignment pins and align Shift Rail E into the Main Housing during installation.

Note: Rotate Output Shaft to align gearing and allow Rear Housing Assembly to fully seat on Main Housing.



Install Harness Bracket

Note: This procedure contains installing the Harness Bracket without the Mechatronic Transmission Module (MTM).

1. Install Harness Bracket



2. Install 3 Harness Bracket 10 mm cap screws and torque to 8.8-10.4 Nm (6-8 lb-ft).



Install Mechatronic Transmission Module (MTM)

1. Place the transmission in a horizontal position.

NOTICE: The transmission must be in a horizontal position prior to the MTM Installation procedure. Failure to do so causes the sliding clutches to move out of neutral and not align to the shift yokes. If the shift yokes are not aligned to the sliding clutches, position sensor fault codes set Active and the transmission will not shift out of neutral.

2. Clean the sealing surfaces on the transmission and Mechatronic Transmission Module (MTM) with Gasket Remover.

NOTICE: Do not use abrasive scrapers or powered tools to clean sealing surfaces or sealing surfaces may be damaged and leak.

3. Inspect threaded bolt holes for debris and clean if necessary.

NOTICE: Ensure there is nothing in the threaded bolt holes or the transmission may be damaged when cap screws are tightened.

4. Install the Rail B Engagement Tool (RR1088TR) to the Main Housing and hand tighten with 2 MTM cap screws.



5. Shift the Rail B Synchronizer to neutral.

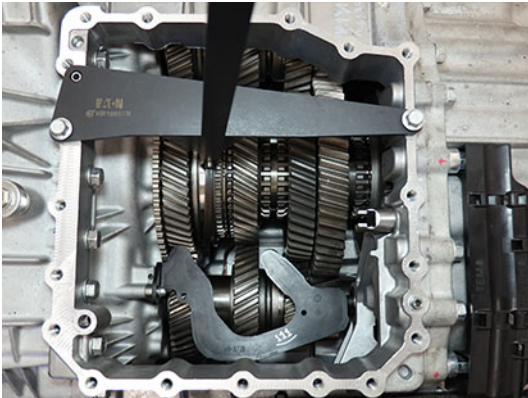

8. Install the Confirm-Neutral Gauge (RR1086TR-2) into the slots of the synchronizer and sliding clutches.



6. Remove the Rail B Engagement Tool.
7. Move Rail C and Rail D sliding clutches to neutral.

NOTICE: The transmission must be in a horizontal position prior to the MTM Installation procedure. Failure to do so causes the sliding clutches to move out of neutral and not align to the shift yokes. If the shift yokes are not aligned to the sliding clutches, position sensor fault codes set Active and the transmission will not shift out of neutral.

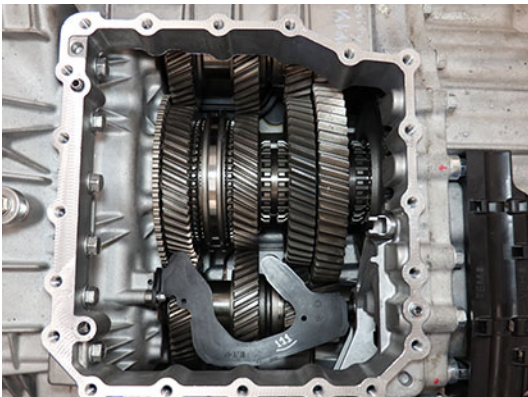
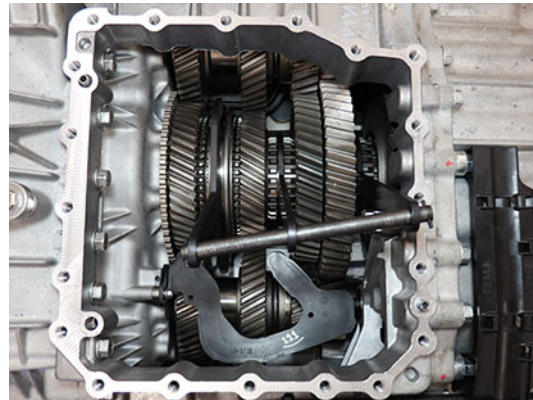

9. Install the MTM Alignment Tool (RR1086TR-1) onto the main housing.

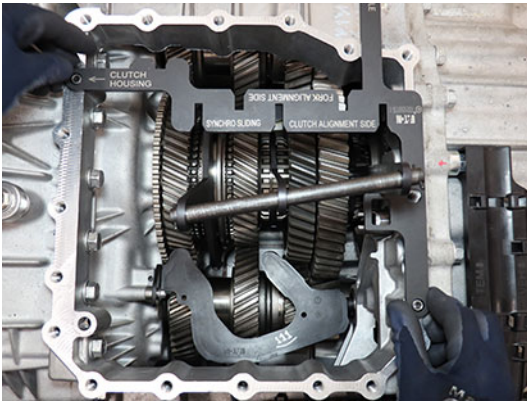
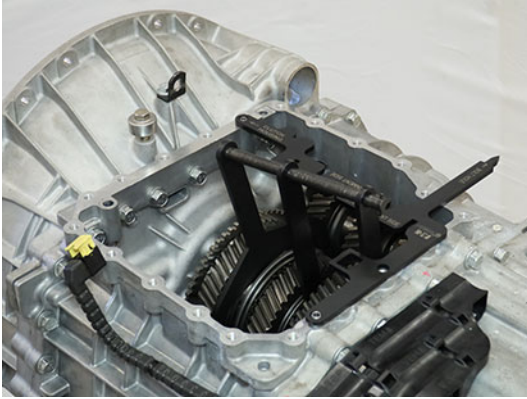

10. Verify synchronizer and sliding clutches are in neutral by sliding Confirm-Neutral Gauge into the slots of MTM Alignment Tool.

Note: If the gauge does not slide into the alignment tool slots, neutral is not achieved. Go to Step 4.

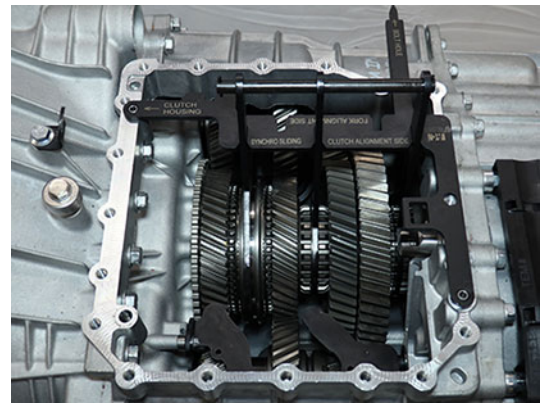

11. Using the Rail E Lever, move Rail E to neutral.

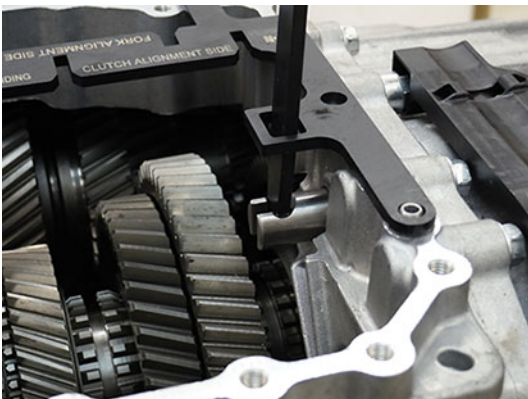
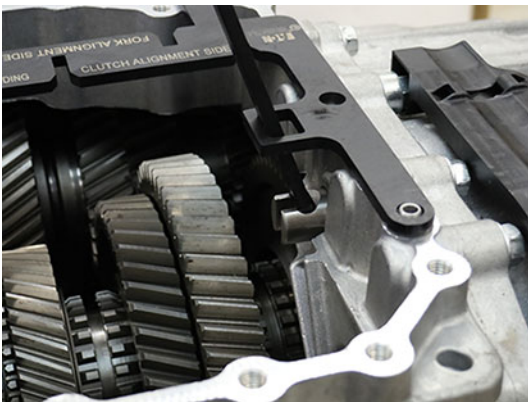
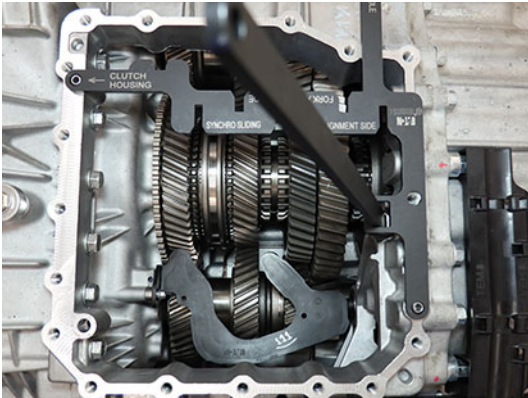

12. Verify Rail E is in neutral using the Gear Side Actuator end of the Confirm-Neutral Gauge (RR1088TR-2) at Shift Rail E. Rail E is in neutral when end of gauge rests against housing with rail against notch-end of gauge.

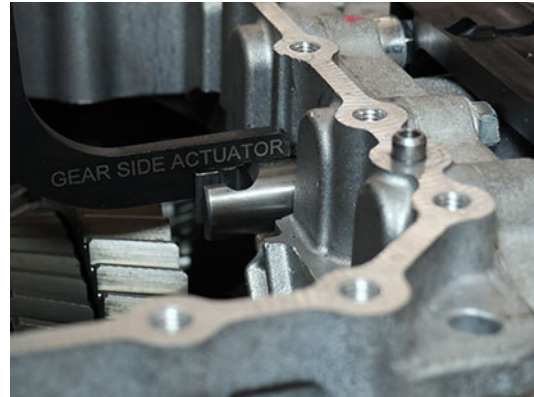

13. Move Shift Rail B in the MTM to neutral. Rail B is in neutral when the ball detent is in the notch of the Rail B yoke assembly.

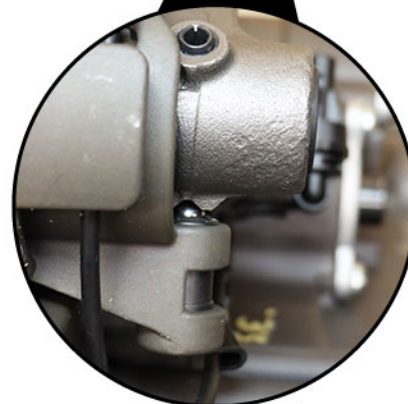
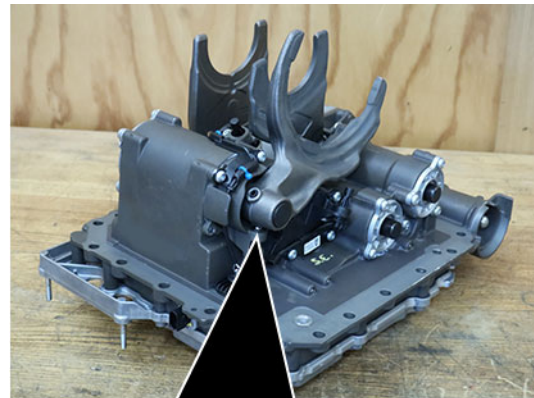

14. Move Shift Rails C and D in the MTM to neutral. Rails C and D are in neutral when the shift inter-lock is aligned with the notches of the rail yoke assemblies.

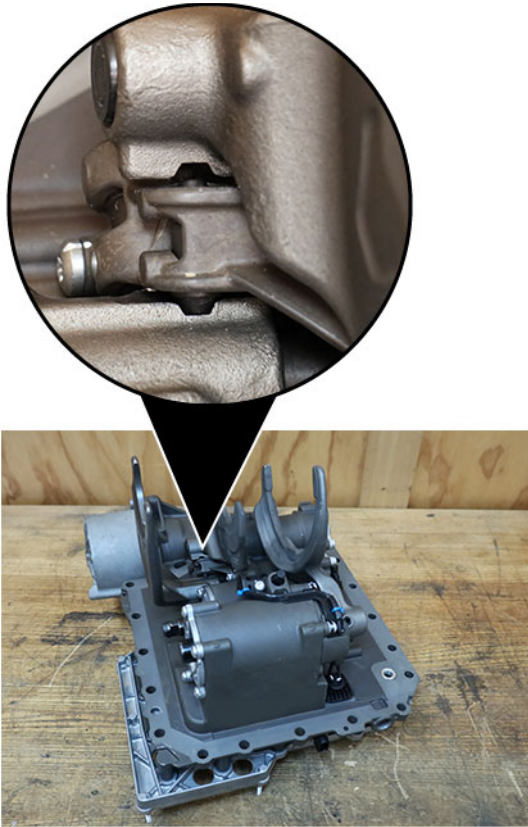

15. Verify MTM is in neutral. Install the MTM Alignment Tool (RR1086TR-1) into the bolt hole and onto Rail B, C, and D Shift Yokes.

Note: If the MTM Alignment Tool slots do not align with the 3 shift yokes, neutral has not been achieved. Go to Step 13.



16. Verify notch on Rail E is facing up.

Note: If the MTM is installed on the transmission with the notch on Rail E facing down, Fault Code 320 (SPN 5942) sets Active and the transmission will not shift out of neutral.

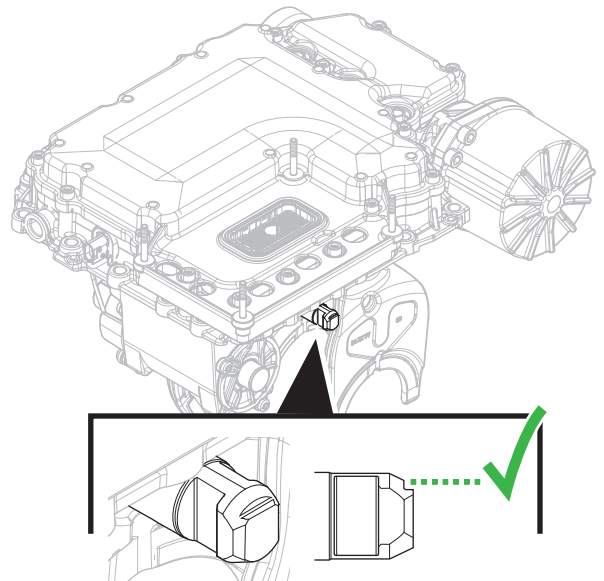

17. Verify Rail E is in neutral using the Fork Side Actuator end of the Confirm-Neutral Gauge (RR1088TR-2) at Shift Rail E. Rail E is in neutral when end of gauge rests against cover with rail against notch-end of gauge.

Note: If Rail E is not in neutral, slide rail in or out until neutral is achieved.

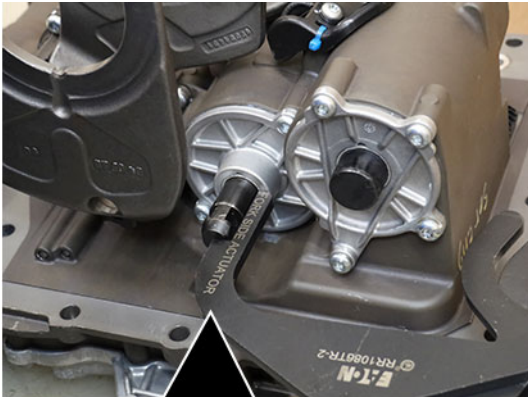

18. Slide new I-Brake MTM to Main Housing O-ring (13653) over the MTM front alignment pin on the main housing until fully seated in the groove.

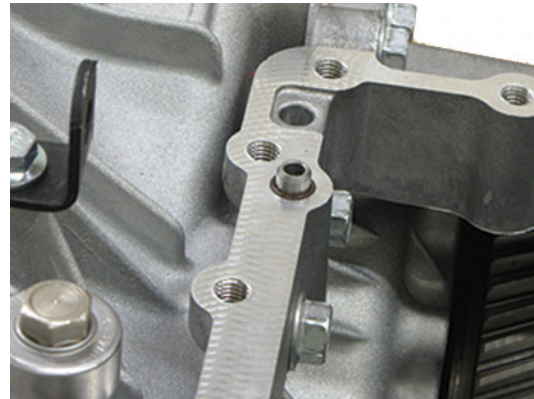

19. Clean the sealing surfaces on the Main Housing and MTM Housing with gasket remover and a plastic scraper. Let air dry then wipe with a clean dry cloth
20. Apply Gasket Sealant with a bead width of 1.4-2.4 mm (0.055-0.094 inch) to the transmission housing sealing surface following the pattern below.

NOTICE: Ensure there is nothing in the threaded bolt holes or the transmission may be damaged when cap screws are tightened.

Note: Parts must be assembled within 10 minutes of applying Gasket Sealant.

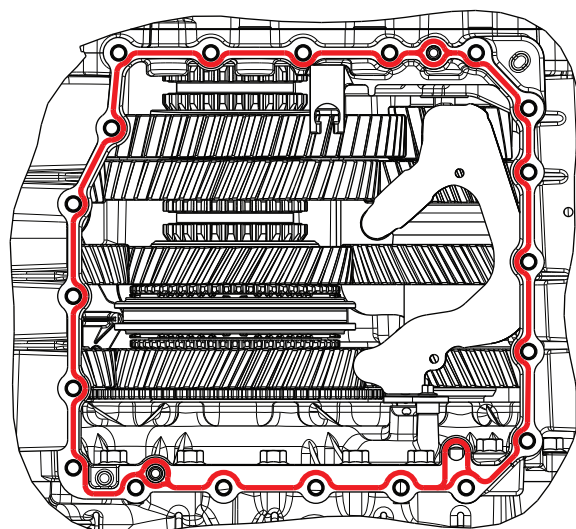

21. Install MTM onto the transmission housing. Align Rail E in the MTM with the Rail E Shift Rail in the Main Housing.

CAUTION: MTM weighs approximately 40 lbs. Keep fingers clear of pinch point between MTM and other surfaces. Dropping MTM could result in component damage and/or personal injury.

NOTICE: If the MTM is installed on the transmission and Rail E in the MTM is not aligned with Rail E in the Main Housing, Fault Code 320 (SPN 5942) sets Active and the transmission will not shift out of neutral.

22. Install 20 MTM cap screws and torque to 44.5-51.5 Nm (33-38 lb-ft) in a criss-cross pattern.

Note: 13 mm (x18), 15 mm (x2) cap screws.

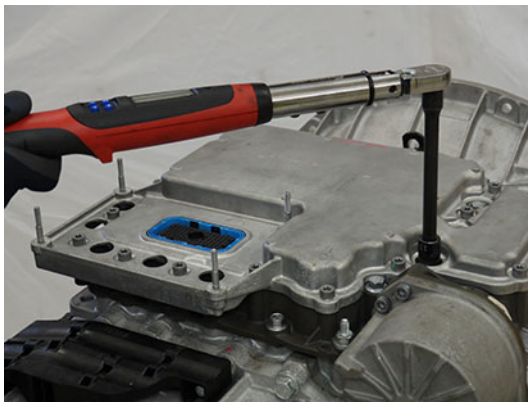

Install Output Speed Sensor

1. Clean the sensor bore.

NOTICE: Do not use abrasive scrapers or powered tools to clean sealing surface.

2. Apply a light coat of transmission oil to the sensor O-ring.
3. Install the Output Speed Sensor into the bore.

Note: The Sensor may need to be twisted and pushed into the bore.



4. Install the Output Speed Sensor 10 mm cap screw and torque to 8.8-10.4 Nm (6-8 lb-ft).



5. Press the 2 harness press-in retainers into the Main Housing and the bracket on the rear housing.



6. Secure the Output Speed Sensor Harness to the Harness Bracket with a tie strap.



CAUTION: Failure to tie strap the Output Speed Sensor Harness to the Harness Bracket may result in harness damage.

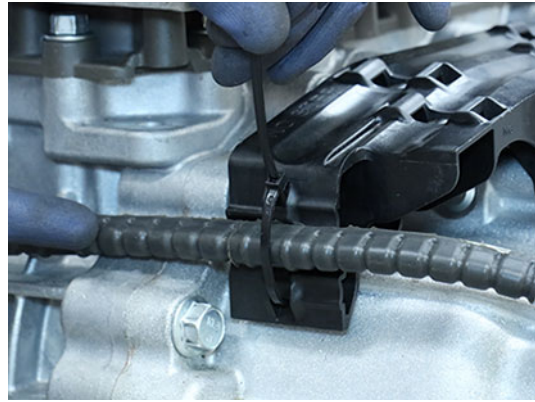

Connect Output Speed Sensor

1. Connect the Output Speed Sensor Harness to the Connector on the Mechatronic Transmission Module (MTM) and close the latch.



Install Transmission Control Module (TCM)

NOTICE: Do not allow contamination into the connectors on the TCM or MTM.

1. Install the TCM Seal on the 74-Way Harness Connector.



2. Align the TCM to the 74-Way Harness Connector and TCM studs and install the TCM.



3. Torque the TCM 7 mm Jackscrew to 3.0-4.0 Nm (26.6-35.4 lb-in).



4. Install the TCM Cover over the 4 TCM studs and torque the 4 TCM Cover Nuts to 8.8-10.4 Nm (78-92 lb-in) in a criss-cross pattern.

Note: TCM Cover nuts are 10 or 13 mm.



Remove the Linear Clutch Actuator (LCA)

1. Loosen the 4 LCA cap screws 1-2 turns each with a T45 Torx.

NOTICE: Ensure key is off, 20-Way TCM Vehicle and Body Harness Connectors are disconnected, and 5 minutes has passed prior to LCA removal.

Note: Residual air pressure in the LCA cylinder exhausts between the LCA and MTM housing when the cap screws are loosened.



2. Remove the 4 LCA cap screws
3. Remove the LCA from the MTM.

Note: LCA piston rod end is seated in the release yoke socket; pull to release rod end from socket.



- Inspect the plastic socket insert in the release yoke through the LCA opening using a flashlight to verify none of the fingers are missing or damaged.

Note: If the plastic insert is damaged, replace the release yoke assembly.

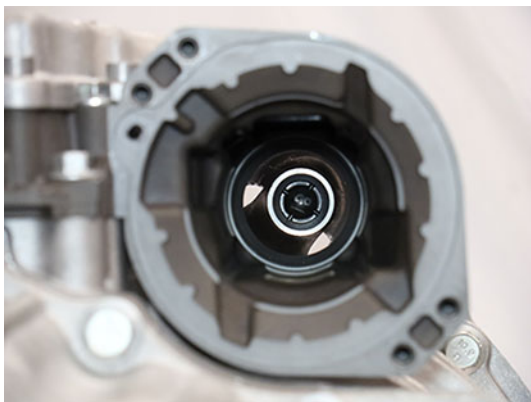

Reset and Install Linear Clutch Actuator (LCA)

- Inspect LCA to determine next steps, reference images below:
 - If LCA is locked in the reset position, go to Install Linear Clutch Actuator (LCA).
 - If LCA is not locked in the reset position, go to Step 2.

Locked in Reset Position

Not Locked in Reset Position

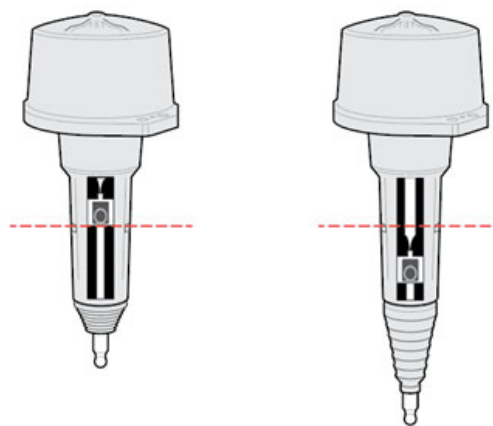

- Place LCA push rod on a clean, flat surface. Tightly grasp LCA housing with both hands and push down on push rod to lock LCA into the reset position.



CAUTION: A large amount of force is required to lock the LCA into the reset position. Failure to tightly grasp the LCA housing with both hands while pushing down on push rod may cause unintended movement resulting in personal injury and/or component damage.

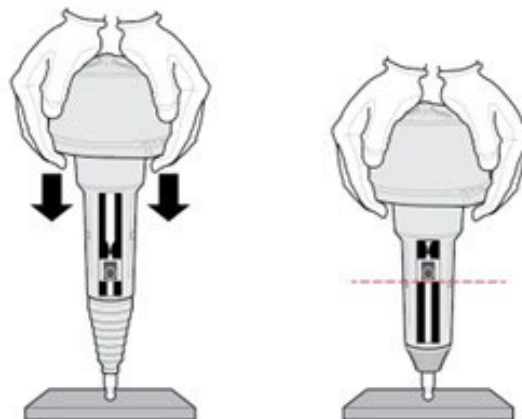

3. Inspect LCA to determine next steps, reference images below:

- If LCA remains locked in the reset position, go to Step 4.
- If LCA does not remain locked in the reset position, go to Step 2, repeat reset procedure.

Note: If LCA cannot be locked into the reset position, replace LCA.



CAUTION: Do not drop LCA. Dropping LCA may cause the LCA to unlock resulting in personal injury and/or component damage.

Locked in Reset Position

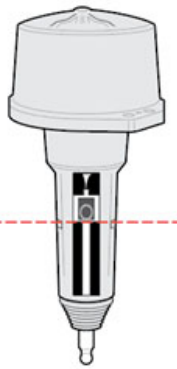

Not Locked in Reset Position

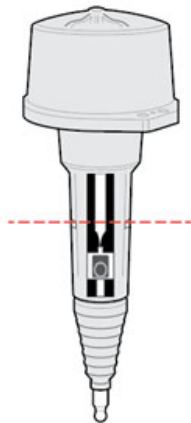

4. Clean all sealing surfaces on the MTM and LCA with a lint free cloth.

NOTICE: Do not use abrasive scrapers or powered tools to clean sealing surfaces or sealing surfaces may be damaged and leak.

5. Insert the LCA into the MTM.



6. Install 4 LCA T45 cap screws and torque to 23-28 Nm (17-21 lb-ft) in a criss-cross pattern.

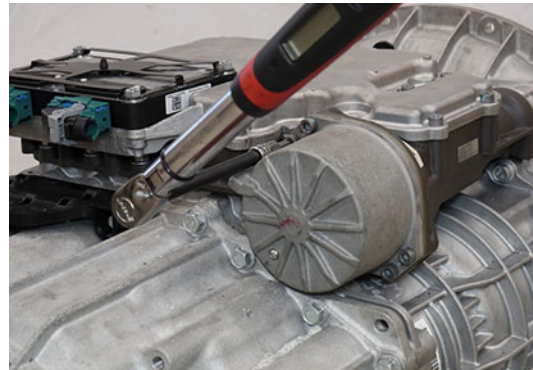

Install the Release Bearing and Clutch Release Yoke

1. Install the upper Release Yoke socket over the rod end of the Linear Clutch Actuator (LCA) and press until attached.



2. Install the lower Release Yoke socket over the lower pivot on the clutch housing and press until attached.

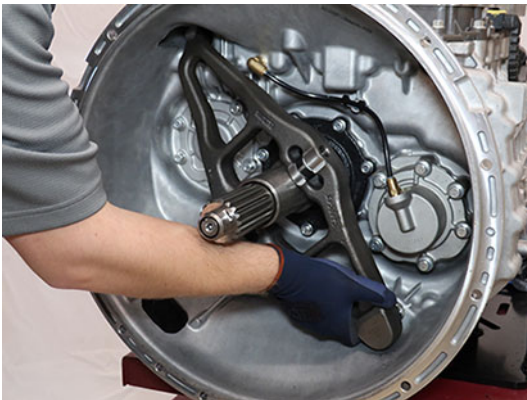

3. Slide the Release Bearing over the input shaft and into the Release Yoke.



Install Transmission

1. Refer to OEM guidelines for transmission installation.
2. Connect negative battery cable.

Fill Oil

Note: Perform the transmission fill procedure with transmission installed in vehicle to ensure proper transmission angle.

1. Remove the Oil Fill Plug with a 6 mm hex key.

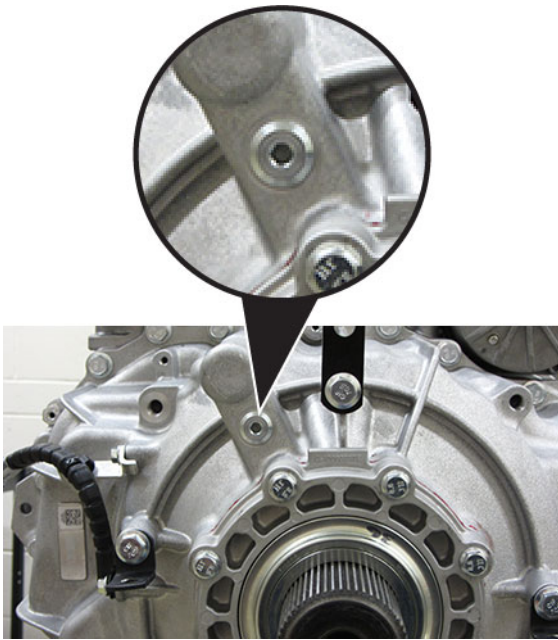

2. Place a suitable container under the Oil Check Plug and remove the Oil Check Plug with a 6 mm hex key.



3. Fill the transmission with PS-386 lube until a small amount of oil runs out of the Oil Check Plug hole.

Note: Fill capacity is approximately 7.5-8.5 liters (16-18 pints) depending on the transmission angle.

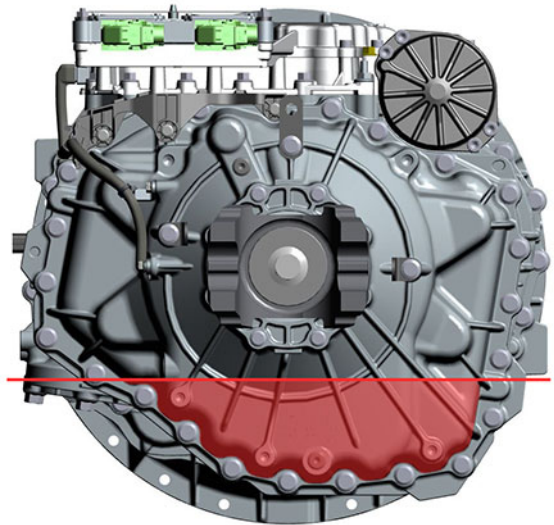
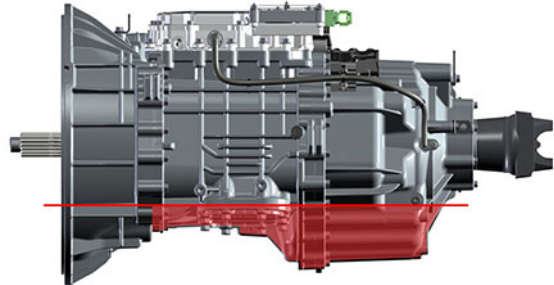

4. Inspect Oil Check Plug and O-ring for damage. If damaged, replace the Oil Check Plug; O-ring is serviced with plug.

5. Install the Oil Check Plug (6 mm) and torque to 24.5-29.5 Nm (18-22 lb-ft).

NOTICE: Do not over-torque the Oil Fill Plug or transmission damage may occur.



6. Inspect Oil Fill Plug and O-ring for damage. If damaged, replace the Oil Fill Plug; O-ring is serviced with plug.
7. Install the Oil Fill Plug (6 mm) and torque to 24.5-29.5 Nm (18-22 lb-ft).

NOTICE: Do not over-torque the Oil Fill Plug or transmission damage may occur.

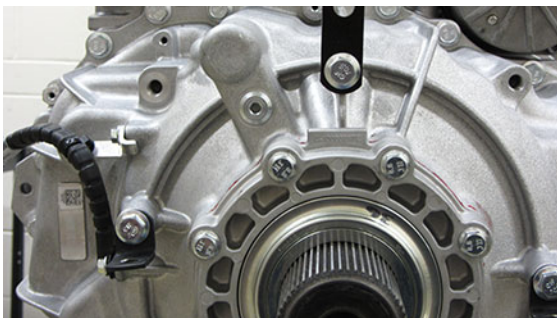

8. Connect the negative battery cable.

Clutch and Rail Calibration

To ensure proper operation, the TCM, clutch, MTM and transmission require a Clutch and Rail Calibration. Calibrations are automatically initiated when:

- LCA is in the reset position
- Transmission in “N” (Neutral)
- Key on engine running
- Vehicle air system pressure at operating range

NOTICE: Do not use service tool to initiate calibrations. Allow calibrations to automatically initiate.

Note: Vehicle display may indicate a flashing “CC” and “F” in gear display.

1. Set vehicle parking brake and chock wheels.
2. Ensure the driveline is connected between the transmission and axle.

Note: Clutch and Rail Calibrations cannot complete if the transmission output shaft is allowed to rotate.
3. Key on with engine running.
4. Allow vehicle air pressure to build to governor cut-off.

Note: Clutch and Rail Calibrations automatically initiate when vehicle air pressure reaches approximately 100 psi.
5. Ensure “N” (Neutral) is selected and engine is running. Wait approximately 2 minutes for calibrations to complete.

NOTICE: If process is interrupted, key off, wait 1 minute and go to **Step 2**.

- If vehicle display indicates a solid “N: (Neutral) in gear display, calibrations are complete. Key off, go to **Step 6**.
 - If vehicle display continues to indicate a flashing “CC” and/or “F” in gear display or service transmission message, go to **Step 5**.
6. Key off and wait 1 minute.

7. Key on with engine off.
8. Connect ServiceRanger.
9. Go to “Fault Codes”.
 - If an Active transmission fault code is set, go to Endurant HD Troubleshooting Guide TRTS0950 **Diagnostic Procedure**.
 - If no Active transmission fault codes are set, select “Clear Eaton Faults” and follow on-screen prompts. Go to **Step 9**.
10. Disconnect ServiceRanger.
11. Key off.
12. Inspect transmission for a PTO.
 - If not PTO-equipped, process complete.
 - If PTO-equipped, start the engine and run for 1 to 2 minutes to fill the PTO with oil, key off and repeat the Fill Oil Procedure.



CAUTION: Failure to repeat the Fill Oil service procedure to verify proper transmission oil level when equipped with a PTO may result in low transmission oil and component damage.

RRMT0027 - Clutch Housing Front Cover Kit

Special Instructions

K-4491 should be installed on transmissions built prior to July 29th, 2019 serial number Z0123456 whenever a transmission is removed. Contact the Roadranger Call Center at 1-800-826-4357 for warranty guidelines. K-4491 will be added to new production transmissions targeted to be built 07/19/2021.

Special Tools

- ServiceRanger
- Transmission Assembly Lube (Lubegard® Assemblee Goo Firm Tack - Green #19250 or equivalent)

NOTICE: Only use the specified transmission assembly lube indicated above. Other types of assembly lube or grease reduce O-ring effectiveness.

- Non-Chlorinated Brake Cleaner



DANGER: Do not handle non-chlorinated brake cleaner until all manufacturer precautions have been read and understood. Failure to follow precautions will result in serious personal injury or death.



CAUTION: Avoid contact between non-chlorinated brake cleaner and the transmission plastic components, electrical wiring and connectors. Failure to avoid contact will result in transmission component damage.

Component Identification

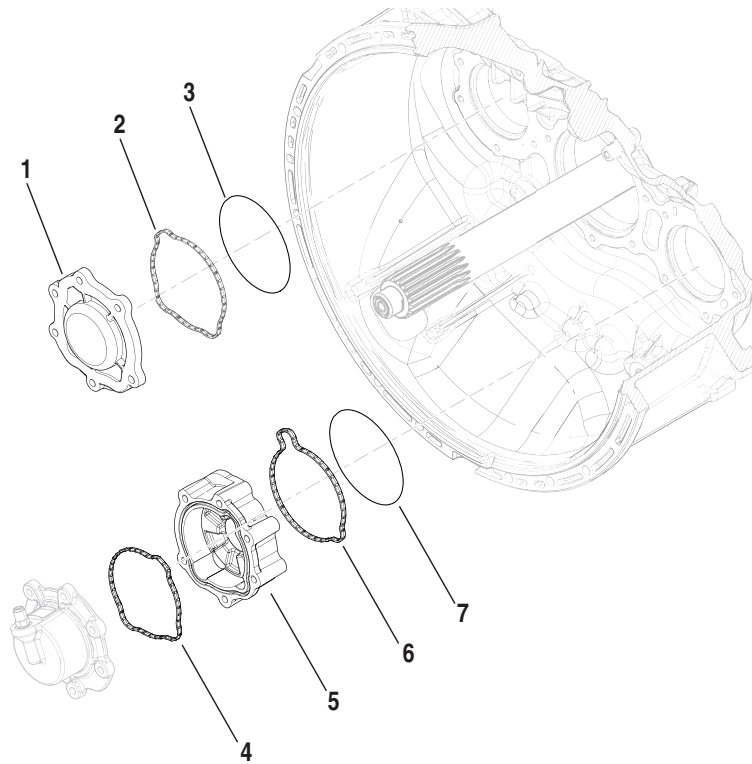

| | Description | P/N | QTY |
|------|--|------------|------------|
| 1 | Upper Countershaft Cover | 10004215 | 1 |
| 2, 4 | Countershaft Cover/Inertia Brake Housing (Front) Seal | 10001048 | 2 |
| 3, 7 | Countershaft Cover/Inertia Brake Housing Countershaft Bearing O-ring | 10004217 | 2 |
| 5 | Inertia Brake Housing | 10004216 | 1 |
| 6 | Inertia Brake Housing (Rear) Seal | 10001049 | 1 |

Manually Vent Linear Clutch Actuator (LCA)

1. Key off.
2. Set vehicle parking brake and chock wheels.

! **WARNING:** Apply vehicle parking brake and follow vehicle manufacture parking instructions. Failure to follow these instructions could cause unintended vehicle movement and may result in major vehicle component damage, severe injury or death.

3. Loosen the 4 Linear Clutch Actuator (LCA) cap screws 1-2 turns each with a T45 Torx.

Note: Residual air pressure in the LCA cylinder exhausts between the LCA and Mechatronic Transmission Module (MTM) housing when the cap screws are loosened.

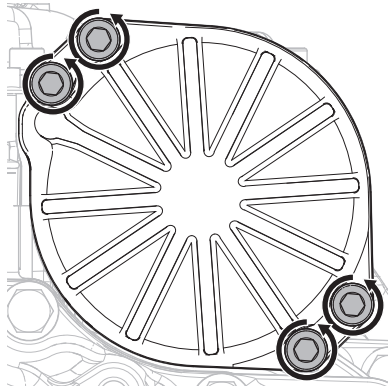

4. Tighten the 4 LCA to MTM T45 cap screws and torque to 23-27 Nm (17-21 lb-ft).

Drain Oil

1. Locate the Oil Drain Plug on the back of the rear housing.
2. Place a suitable container under the Oil Drain Plug.

Note: Original oil is not to be reused.

3. Remove the Oil Drain Plug with a 6 mm hex key and drain the oil.

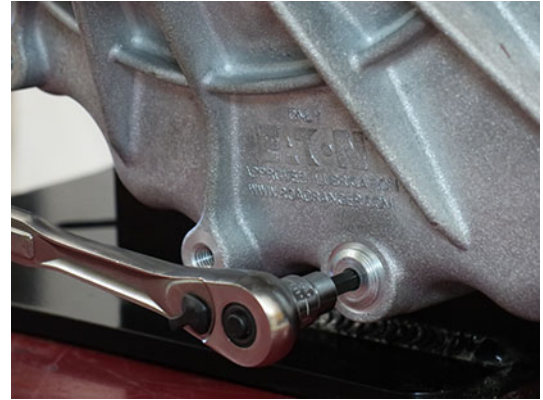

4. Inspect Oil Drain Plug and O-ring for damage. If damaged, replace the Oil Drain Plug; O-ring is serviced with plug.
5. Install the Oil Drain Plug (6 mm) and torque to 24.5-29.5 Nm (18-22 lb-ft).

NOTICE: Do not over-torque drain plug or transmission damage may occur.



Remove Transmission

1. Disconnect negative battery cable.
2. Refer to OEM guidelines for transmission removal.

Remove Release Bearing and Clutch Release Yoke

1. Remove the Release Bearing by sliding the bearing off the Input Shaft Cover.



2. Pull to free the lower Clutch Release Yoke socket from the lower pivot on the clutch housing.

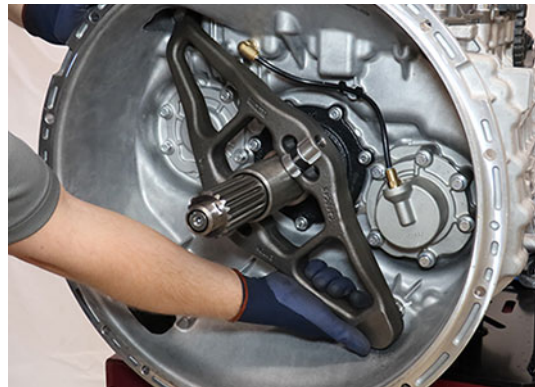

3. Pull to free the upper Clutch Release Yoke socket from the Linear Clutch Actuator (LCA) rod end.



Remove Upper Countershaft Cover

1. Remove the 6 Upper Countershaft Cover 13 mm cap screws and remove cover. The original Upper Countershaft Cover and Front Seal are not to be reused.

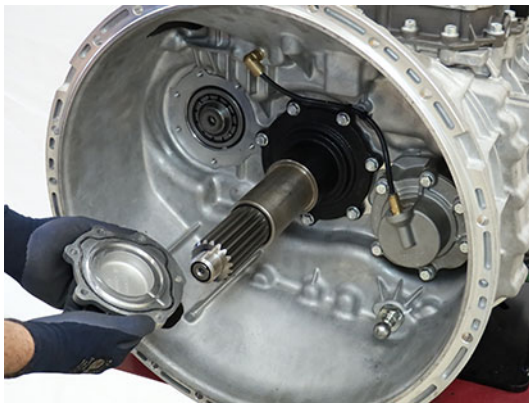

Install Upper Countershaft Cover Countershaft Bearing O-ring

1. Clean any residual oil from the Upper Countershaft Bearing outer diameter using Non-Chlorinated Brake Cleaner.
2. Install the Upper Countershaft Cover Countershaft Bearing O-ring (10004217) onto the Upper Countershaft Bearing.

Note: O-ring may fall out of position after installation. Ensure to clean any residual oil from the bearing and roll the O-ring on to the bearing using the tips of your fingers pushing on the inner diameter of the O-ring. If necessary, apply a small amount of transmission assembly lube at the 3, 6, 9 and 12 o'clock positions to the outer diameter of the bearing.



Install Upper Countershaft Cover

1. Clean the sealing surfaces on the clutch housing and the new Upper Countershaft Cover.

Note: The new Upper Countershaft Cover has a chamfer that is required for the bearing O-ring.



2. Install new Countershaft Cover front seal (10001048) into the groove of the new Upper Countershaft Cover (10004215) until fully seated



3. Install the new Upper Countershaft Cover and six 13 mm cap screws to the clutch housing and torque to 21-25 Nm (16-19 lb-ft) in a criss-cross pattern.



Remove Lower Countershaft Cover and Inertia Brake

1. Depress and hold collar on air line fitting and disconnect the air line from the Inertia Brake Cover.

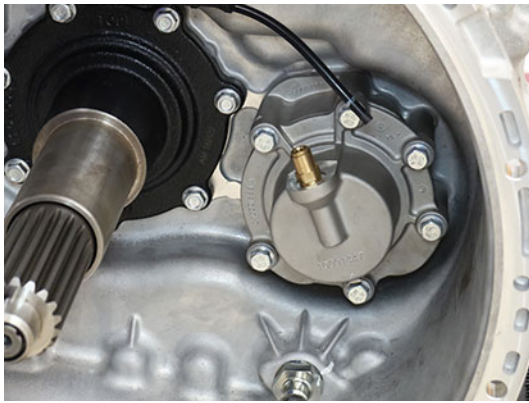

2. Remove the 6 Inertia Brake Cover 13 mm cap screws.



3. Remove the Inertia Brake Cover and Housing as an assembly. The original Inertia Brake Housing and seals are not to be reused.



4. Ensure the Inertia Brake Piston Pin and Return Spring remain in the Lower Countershaft.



Disassemble Inertia Brake

1. Remove the clutch pack from the Inertia Brake Housing.



2. Remove the 2 wear guides from the Inertia Brake Housing.



Assemble Inertia Brake

1. Clean sealing surfaces on the clutch housing and the new Inertia Brake Housing.

Note: The new Inertia Brake Housing (10004216) has a chamfer on the Clutch Housing side that is required for the bearing O-ring.



2. Insert the new Inertia Brake Rear Seal (10001049) into the groove on the rear of the new Inertia Brake Housing (10004216) until fully seated.



4. Install the 2 original Wear Guides into the new Inertia Brake Housing (10004216).



3. Insert the new Inertia Brake Housing Front Seal (10001048) into the new Inertia Brake Housing (10004216) until fully seated.



5. Install the original inertia brake clutch pack in the order shown below:

- 1 Steel Disc,
- 1 Friction Disc,
- 2 Steel Discs,
- 1 Friction Disc,
- 2 Steel Discs,
- 1 Friction Disc, and
- 1 Steel Disc.

Note: Steel Discs align with Wear Guides. Friction Discs spline to the lower countershaft.

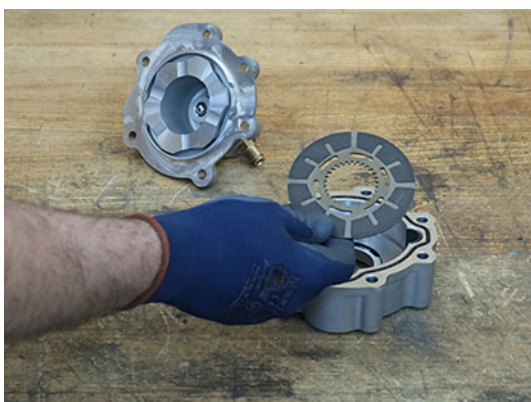
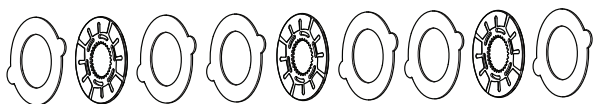

Install Inertia Brake Housing Countershaft Bearing O-ring

1. Clean any residual oil from the Lower Countershaft Bearing outer diameter using Non-Chlorinated Brake Cleaner.
2. Install the Inertia Brake Housing Countershaft Bearing O-ring (10004217) onto the Lower Countershaft Bearing.

Note: O-ring may fall out of position after installation. Ensure to clean any residual oil from the bearing and roll the O-ring on to the bearing using the tips of your fingers pushing on the inner diameter of the O-ring. If necessary, apply a small amount of transmission assembly lube at the 3, 6, 9 and 12 o'clock positions to the outer diameter of the bearing.



6. Place Inertia Brake Cover and Piston on the Housing. Align the bolt holes.

Install Inertia Brake Cover and Housing

1. Install the Inertia Brake Cover and the new Housing as an assembly over the Lower Countershaft, rotate the assembly to align the Friction Discs to the Lower Countershaft splines and seat the assembly to the clutch housing.



2. While holding the Inertia Brake Housing to the clutch housing, remove the Inertia Brake Cover.

NOTICE: Ensure the Friction Discs are splined to the lower countershaft and Wear Guides are fully seated.



3. If removed, install the Return Spring into the Lower Countershaft.

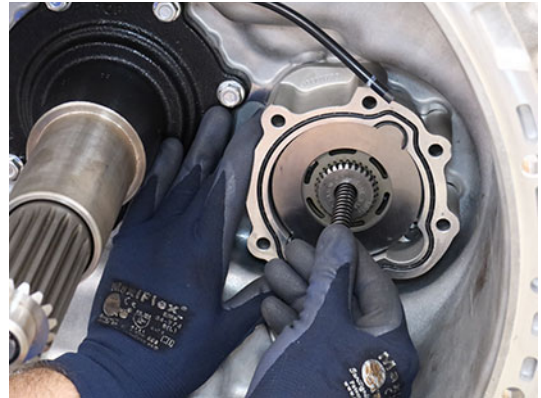

4. If removed, install the Piston Pin into the Lower Countershaft.



5. Install the Inertia Brake Cover onto the housing.

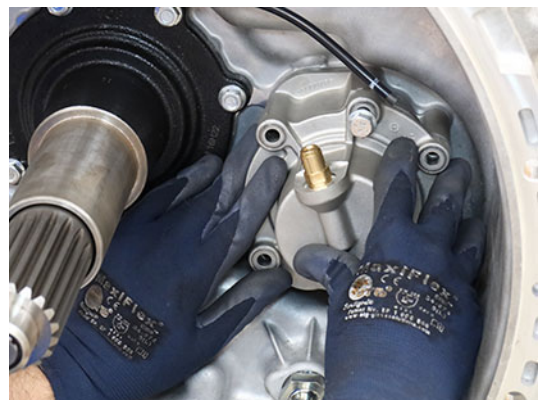

6. Install the six 13 mm cap screws and torque to 21-25 Nm (16-19 lb-ft) in a criss-cross pattern.



7. Insert air line in push-to-connect fitting on the Inertia Brake Cover.



Remove the Linear Clutch Actuator (LCA)

1. Loosen the 4 LCA cap screws 1-2 turns each with a T45 Torx.

NOTICE: Ensure key is off, 20-Way TCM Vehicle and Body Harness Connectors are disconnected, and 5 minutes has passed prior to LCA removal.

Note: Residual air pressure in the LCA cylinder exhausts between the LCA and MTM housing when the cap screws are loosened.



2. Remove the 4 LCA cap screws
3. Remove the LCA from the MTM.

Note: LCA piston rod end is seated in the release yoke socket; pull to release rod end from socket.



- Inspect the plastic socket insert in the release yoke through the LCA opening using a flashlight to verify none of the fingers are missing or damaged.

Note: If the plastic insert is damaged, replace the release yoke assembly.

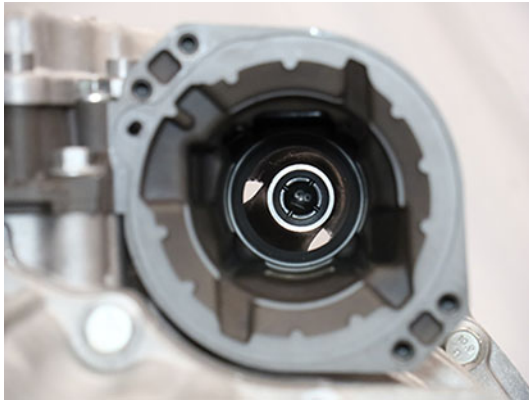

Reset and Install Linear Clutch Actuator (LCA)

- Inspect LCA to determine next steps, reference images below:
 - If LCA is locked in the reset position, go to Install Linear Clutch Actuator (LCA).
 - If LCA is not locked in the reset position, go to Step 2.

Locked in Reset Position

Not Locked in Reset Position

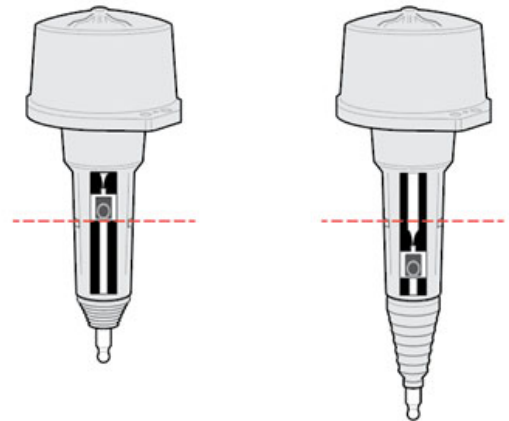

- Place LCA push rod on a clean, flat surface. Tightly grasp LCA housing with both hands and push down on push rod to lock LCA into the reset position.



CAUTION: A large amount of force is required to lock the LCA into the reset position. Failure to tightly grasp the LCA housing with both hands while pushing down on push rod may cause unintended movement resulting in personal injury and/or component damage.

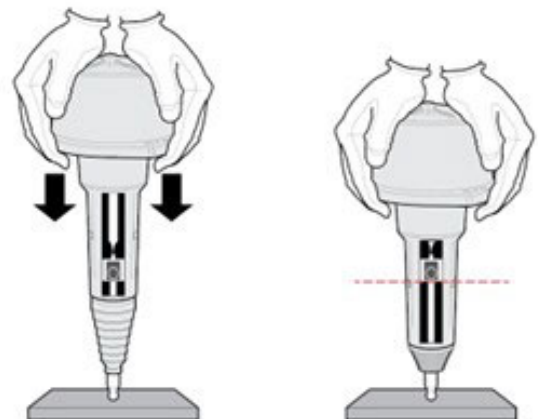

3. Inspect LCA to determine next steps, reference images below:

- If LCA remains locked in the reset position, go to Step 4.
- If LCA does not remain locked in the reset position, go to Step 2, repeat reset procedure.

Note: If LCA cannot be locked into the reset position, replace LCA.



CAUTION: Do not drop LCA. Dropping LCA may cause the LCA to unlock resulting in personal injury and/or component damage.

Locked in Reset Position

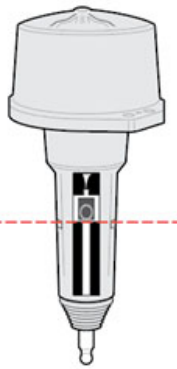

Not Locked in Reset Position

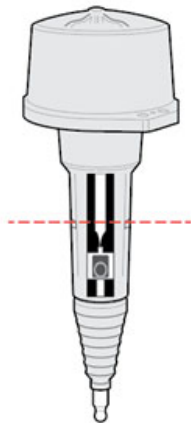

4. Clean all sealing surfaces on the MTM and LCA with a lint free cloth.

NOTICE: Do not use abrasive scrapers or powered tools to clean sealing surfaces or sealing surfaces may be damaged and leak.

5. Insert the LCA into the MTM.



6. Install 4 LCA T45 cap screws and torque to 23-28 Nm (17-21 lb-ft) in a criss-cross pattern.

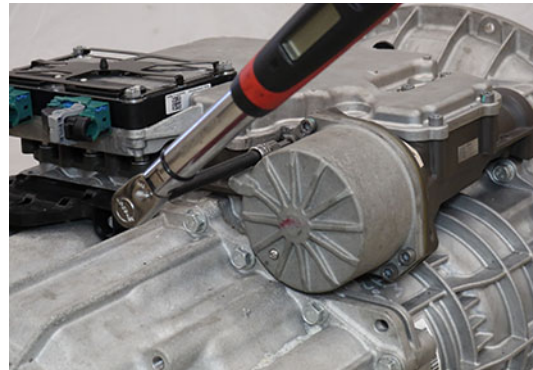

Install the Release Bearing and Clutch Release Yoke

1. Install the upper Release Yoke socket over the rod end of the Linear Clutch Actuator (LCA) and press until attached.



2. Install the lower Release Yoke socket over the lower pivot on the clutch housing and press until attached.

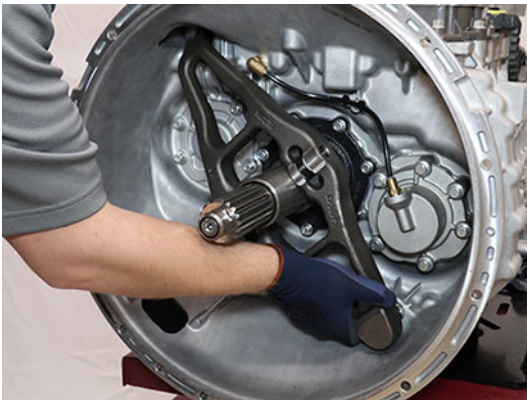

3. Slide the Release Bearing over the input shaft and into the Release Yoke.



Install Transmission

1. Refer to OEM guidelines for transmission installation.
2. Connect negative battery cable.

Fill Oil

1. Remove the Oil Fill Plug with a 6 mm hex key.

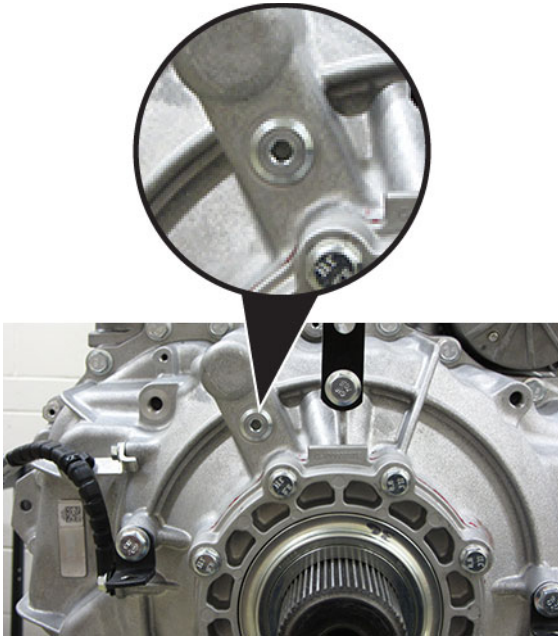

2. Place a suitable container under the Oil Check Plug and remove the Oil Check Plug with a 6 mm hex key.



3. Fill the transmission with PS-386 lube until a small amount of oil runs out of the Oil Check Plug hole.

Note: Fill capacity is approximately 7.5-8.5 liters (16-18 pints) depending on the transmission angle.

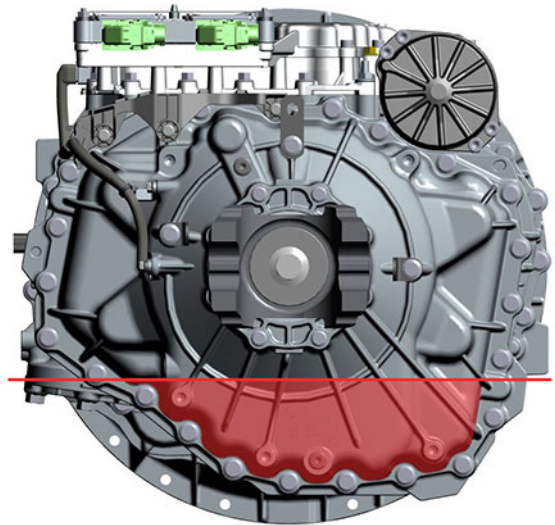
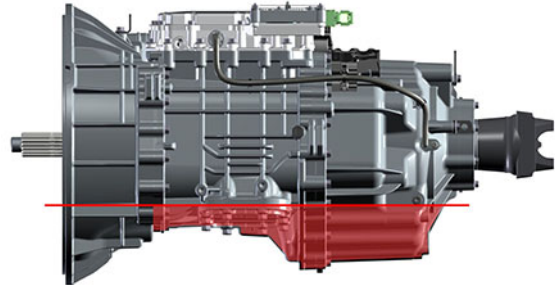

4. Inspect Oil Check Plug and O-ring for damage. If damaged, replace the Oil Check Plug; O-ring is serviced with plug.

5. Install the Oil Check Plug (6 mm) and torque to 24.5-29.5 Nm (18-22 lb-ft).

NOTICE: Do not over-torque the Oil Fill Plug or transmission damage may occur.



6. Inspect Oil Fill Plug and O-ring for damage. If damaged, replace the Oil Fill Plug; O-ring is serviced with plug.
7. Install the Oil Fill Plug (6 mm) and torque to 24.5-29.5 Nm (18-22 lb-ft).

NOTICE: Do not over-torque the Oil Fill Plug or transmission damage may occur.

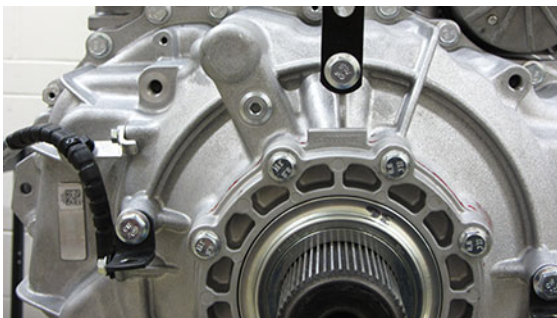

Clutch and Rail Calibration

To ensure proper operation, the TCM, clutch, MTM and transmission require a Clutch and Rail Calibration. Calibrations are automatically initiated when:

- LCA is in the reset position
- Transmission in “N” (Neutral)
- Key on engine running
- Vehicle air system pressure at operating range

NOTICE: Do not use service tool to initiate calibrations. Allow calibrations to automatically initiate.

Note: Vehicle display may indicate a flashing “CC” and “F” in gear display.

1. Set vehicle parking brake and chock wheels.
2. Ensure the driveline is connected between the transmission and axle.

Note: Clutch and Rail Calibrations cannot complete if the transmission output shaft is allowed to rotate.
3. Key on with engine running.
4. Allow vehicle air pressure to build to governor cut-off.

Note: Clutch and Rail Calibrations automatically initiate when vehicle air pressure reaches approximately 100 psi.
5. Ensure “N” (Neutral) is selected and engine is running. Wait approximately 2 minutes for calibrations to complete.

NOTICE: If process is interrupted, key off, wait 1 minute and go to **Step 2**.

- If vehicle display indicates a solid “N: (Neutral) in gear display, calibrations are complete. Key off, go to **Step 6**.
 - If vehicle display continues to indicate a flashing “CC” and/or “F” in gear display or service transmission message, go to **Step 5**.
6. Key off and wait 1 minute.

7. Key on with engine off.
8. Connect ServiceRanger.
9. Go to “Fault Codes”.
 - If an Active transmission fault code is set, go to Endurant HD Troubleshooting Guide TRTS0950 **Diagnostic Procedure**.
 - If no Active transmission fault codes are set, select “Clear Eaton Faults” and follow on-screen prompts. Go to **Step 9**.
10. Disconnect ServiceRanger.
11. Key off.
12. Inspect transmission for a PTO.
 - If not PTO-equipped, process complete.
 - If PTO-equipped, start the engine and run for 1 to 2 minutes to fill the PTO with oil, key off and repeat the Fill Oil Procedure.



CAUTION: Failure to repeat the Fill Oil service procedure to verify proper transmission oil level when equipped with a PTO may result in low transmission oil and component damage.

Harness Bracket Service Procedure

Special Instructions

The Harness Bracket can be removed and installed with the transmission in-vehicle.

Special Tools

None

Component Identification

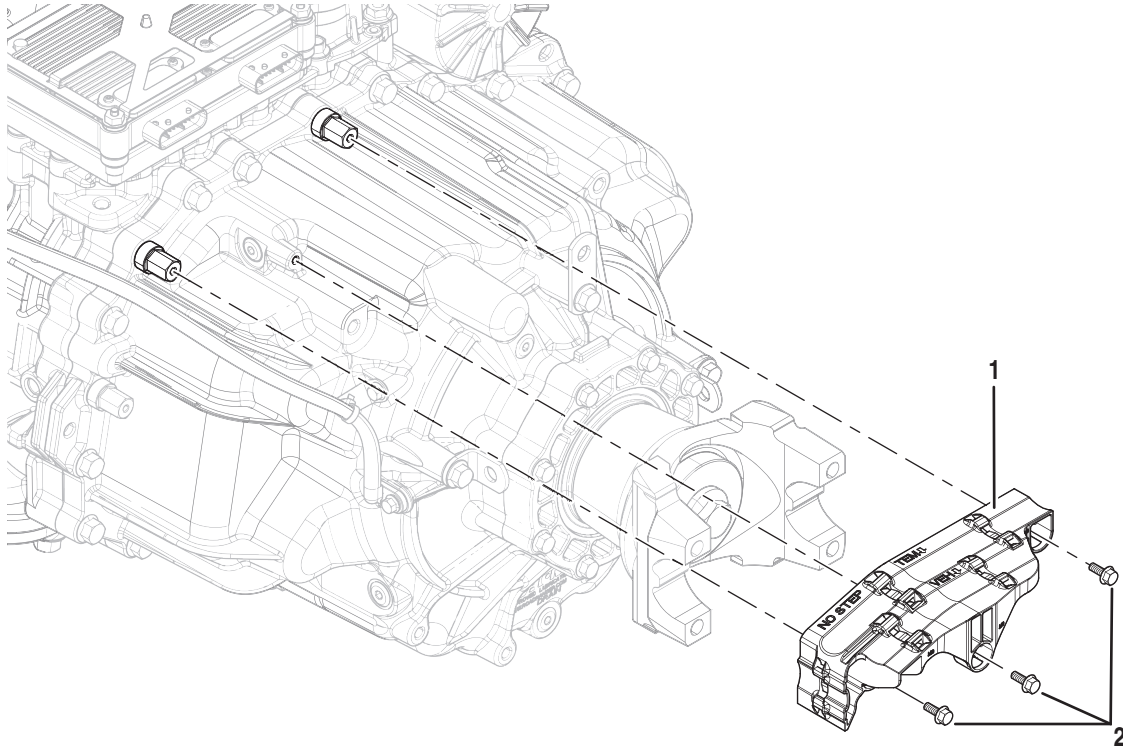

1. Harness Bracket
2. Harness Bracket Cap Screws (x3) - 10 mm

Remove the Harness Bracket

Note: This procedure contains removing the Harness Bracket without the Mechatronic Transmission Module (MTM).

1. Remove 3 Harness Bracket 10 mm cap screws.



2. Remove Harness Bracket.



Install the Harness Bracket

Note: This procedure contains installing the Harness Bracket without the Mechatronic Transmission Module (MTM).

1. Install Harness Bracket.



2. Install 3 Harness Bracket 10 mm cap screws and torque to 8.8 - 10.4 Nm (6-8 lb-ft).



Change Log

| Date | Description |
|----------------|--|
| May 2026 | Updated: Vehicle Maintenance Recommendations |
| January 2026 | Added: Clutch Kits Caution statement |
| December 2025 | Updated: Clutch Kits |
| September 2025 | Updated: Clutch Service Procedure, Vehicle Maintenance Recommendations, Clutch and Rail Calibration Procedure |
| May 2025 | Updated: Input Shaft Kits, MTM Rail BCD Cylinder Service Procedure, Bearing Lock Template Note |
| February 2025 | Updated: New Replacement TCM Service Procedure |
| January 2025 | Updated: Single PTO Identification Table, Main Shaft and Countershaft Service Procedure, Input Shaft Disassembly and Assembly Procedure |
| December 2024 | Updated: Changed all references from “Navistar” to “International Motors”, MTM Service Procedure, Clutch Kits |
| October 2024 | Updated: Clutch Kits Table |
| August 2024 | Updated: LCA Reset Procedure Clutch and Rail Calibration |
| June 2024 | Updated: Clutch Service Procedure - Diaphragm Spring Finger Height |
| May 2024 | Updated: OEM Kits |
| April 2024 | Removed: Clutch Housing, Main Housing and Rear Housing Parts and Kits (These can now be found in the Endurant HD Parts Book TRPB0950) Updated: MTM Rail B,C,D Cylinder Inspection Procedure, New Replacement TCM Service Procedure, Rear Housing Disassembly/Assembly Procedure, Clutch Service Kits Table |

| Date | Description |
|----------------|---|
| March 2024 | Updated: MTM Part Label Image, Nomenclature MTM Rail B,C,D Cylinder Inspection Procedure Linear Clutch Actuator (LCA) Kit Number Change Obsoleted K-4362 (replaced with K-4569) Obsoleted K-4485 (replaced with K-4694) Added: New Replacement TCM Service Procedure |
| January 2024 | Updated: K-4482 was reinstated 01/01/2024 with a limited number of kits. |
| December 2023 | Added: Informational note regarding K-4653 |
| November 2023 | Added: Anaerobic Sealant to Main Housing Kits |
| October 2023 | Removed: RRMT0037 |
| September 2023 | Updated: MTM Rail B,C,D Cylinder Service Procedure MTM Rail B,C,D Cover Cap Screw Service Procedure MTM Rail B,C,D Cylinder Inspection Procedure Clutch Service Procedure Clutch Housing Service Kits |
| August 2023 | Updated: RRMT-0037, LCA Service Procedure, TCM Service Procedure |
| July 2023 | Updated: OEM, Clutch, Main, and Rear Housing Service Kits |
| May 2023 | Updated: Vehicle Maintenance MTM Service Procedure Rail B, C, D Inspection Procedure |
| March 2023 | Added: Bearing Lock Templates Updated: OEM, Clutch, Main and Rear Housing Service Kits Service Kits and Parts Index Main Housing Disassembly / Assembly Procedure Clutch Housing Disassembly / Assembly Procedure |
| February 2023 | Updated: MTM Rail B, C, and D Cylinder Inspection Procedure MTM Rail B, C, and D Cylinder Service Procedure |

| Date | Description |
|----------------|--|
| December 2022 | Added: MTM Rail B, C, and D Cylinder Inspection Procedure MTM Rail B, C, and D Cylinder Service Procedure MTM Rail B, C, and D Cover Cap Screw Service Procedure Updated: Main Housing Service Kits Mechatronic Transmission Module (MTM) Service Procedure Clutch Service Procedure - Diaphragm Spring Finger Height RRMT0037 |
| October 2022 | Updated: RRMT0037, Clutch Housing Front Cover Kit, Clutch Service Procedure |
| September 2022 | Updated: Clutch Service Procedure, Main Housing Service Kits |
| August 2022 | Updated: OEM and Engine Specific Kits |
| May 2022 | Updated: Service Kit K-4361 MTM Service Procedure |
| April 2022 | Updated verbiage on Clutch Service Kits |
| January 2022 | Updated: Roadranger Specialty Tools, OEM and Engine Specific Kits |
| July 2021 | Updated: Warnings and Cautions Service Kits and Parts Index Transmission Service Procedure Transmission Control Module (TCM) Service Procedure Upper Countershaft Cover Service Procedure Input Shaft Cover Service Procedure Lower Countershaft Cover and Inertia Brake Service Procedure Main Shaft End-Play Service Procedure Lower Countershaft Cover and Inertia Brake Disassembly/Assembly Service Procedures Input Shaft Cover Disassembly/Assembly Service Procedures Inspections Precautions RRMT0027 - Clutch Housing Front Cover Kit RRMT0037 - Mechatronic Transmission Module (MTM) Rail Cover Cap Screw Service Procedure |
| April 2021 | Updated: Clutch Service Procedure Clutch Service Kits |
| March 2021 | Updated: OEM and Engine Specific Transmission Kits Clutch Housing Service Kits Main Housing Service Kits |
| August 2020 | Added Appendix information for the Clutch Housing Front Cover Kit Updated Service Kits and Parts Index Updated Service Kit Rear |
| March 2020 | Added Service Kits and Parts Index |

| Date | Description |
|--------------|-----------------------|
| January 2020 | Updated to new format |

Copyright Eaton, 2026.

Eaton hereby grant their customers, vendors, or distributors permission to freely copy, reproduce and/or distribute this document in printed format. It may be copied only in its entirety without any changes or modifications. THIS INFORMATION IS NOT INTENDED FOR SALE OR RESALE, AND THIS NOTICE MUST REMAIN ON ALL COPIES.

Note: Features and specifications listed in this document are subject to change without notice and represent the maximum capabilities of the software and products with all options installed. Although every attempt has been made to ensure the accuracy of information contained within, Eaton makes no representation about the completeness, correctness or accuracy and assumes no responsibility for any errors or omissions. Features and functionality may vary depending on selected options.

For spec'ing or service assistance, call 1-800-826-HELP (4357) or visit www.eaton.com/roadranger. In Mexico, call 001-800-826-4357.

Roadranger: Eaton and trusted partners providing the best products and services in the industry, ensuring more time on the road.

Eaton
Vehicle Group
13100 E. Michigan Ave.
Galesburg, MI 49053 USA
800-826-HELP (4357)
www.eaton.com/roadranger

Printed in USA